

Bare Bones

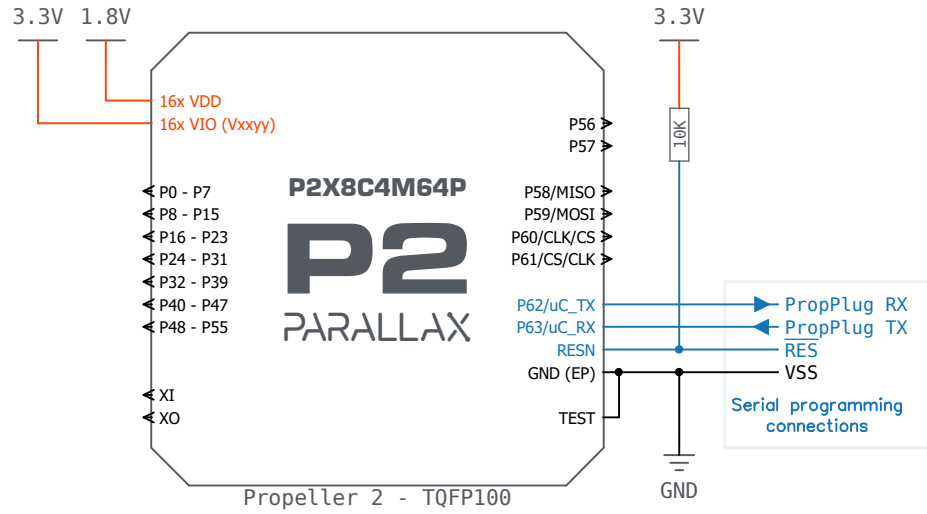

Dual Boot Memory

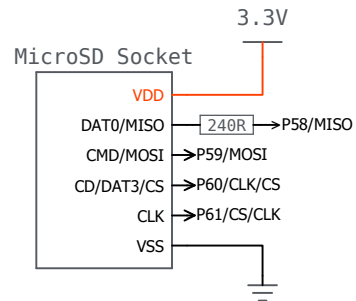
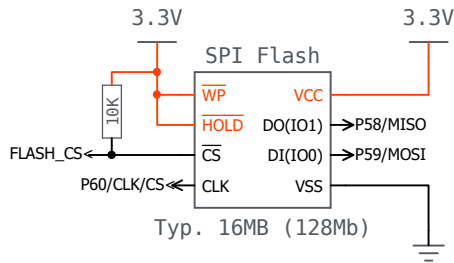
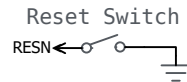
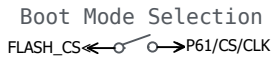
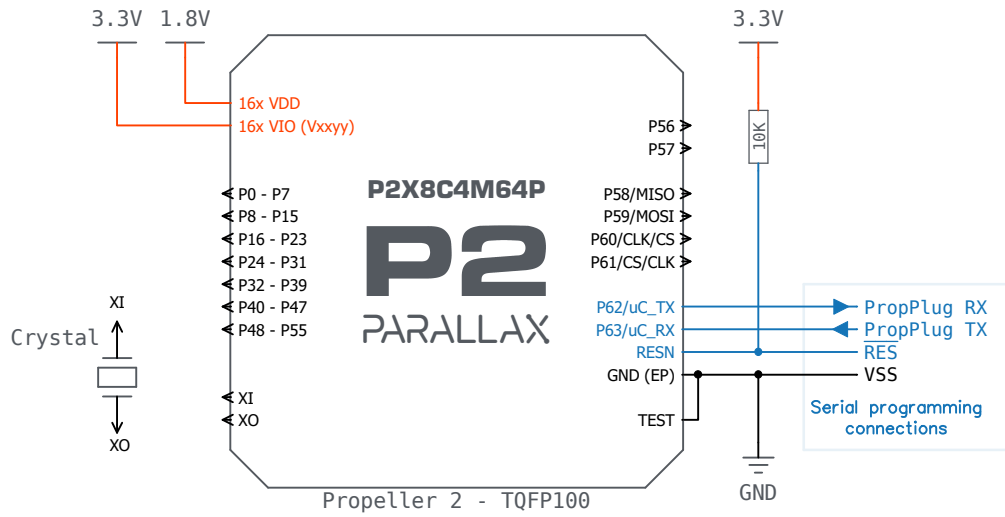

Switch closed = boot from Flash
 (Serial programming window of 100 ms, then SPI flash.
 If SPI flash fails then serial window of 60 seconds)

Switch open = boot from SD card
 (SD card with serial programming window on failure.
 If SD card fails then serial window of 60 seconds)

Single Boot Memory

