

Second propeller loader - P0 to Reset, P1 to P31, P2 to P30, P3 to P29  
 Can also be used as an SPI (and I2C) interface once programmed

If installing prop plug leave out max3232 and associated components  
 As well as reset transistor and associated components

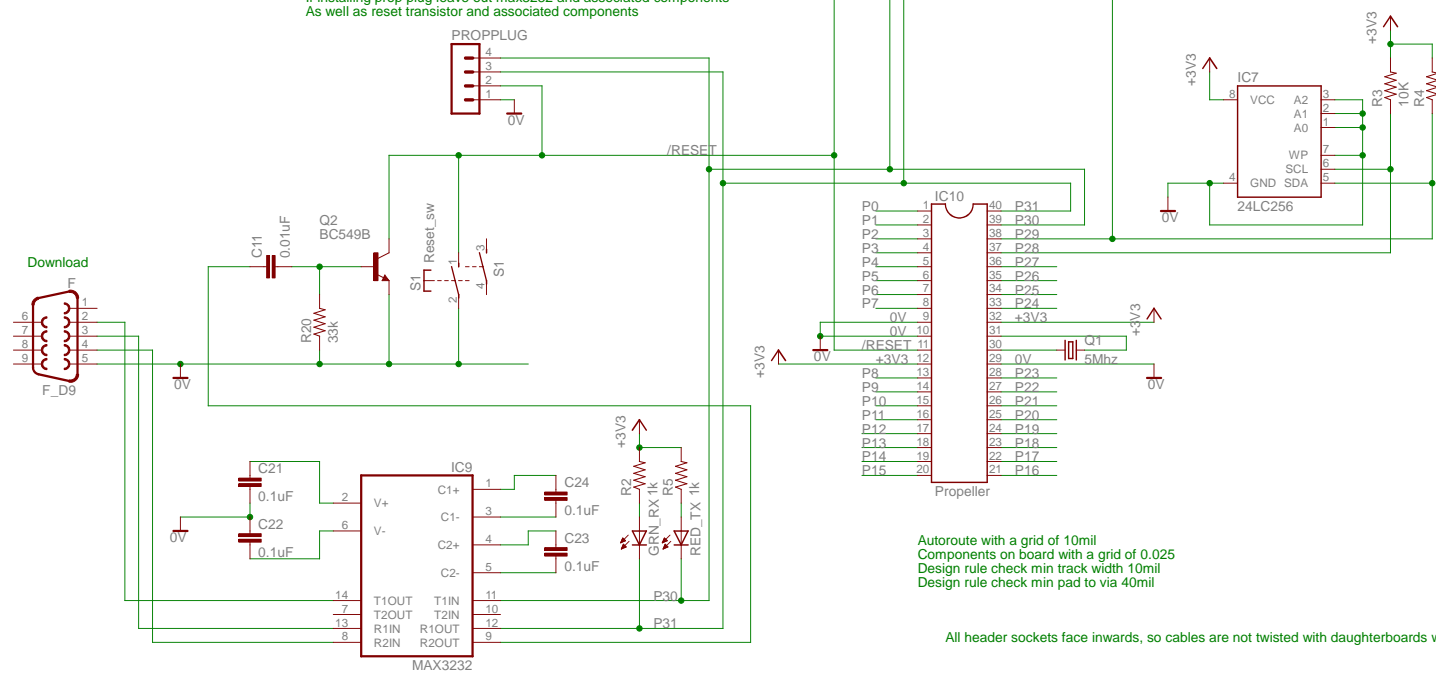

Autoroute with a grid of 10mil  
 Components on board with a grid of 0.025  
 Design rule check min track width 10mil  
 Design rule check min pad to via 40mil

All header sockets face inwards, so cables are not twisted with daughterboards where the header faces outwards.

