

Autoroute with a grid of 10mil
Components on board with a grid of 0.025
Design rule check min track width 10mil
Design rule check min pad to via 40mil

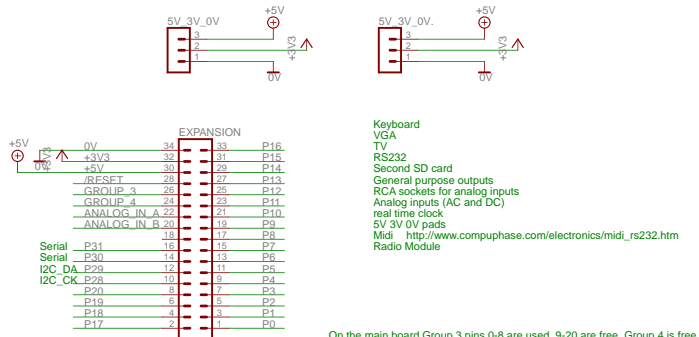

On the main board Group 3 pins 0-8 are used, 9-20 are free. Group 4 is free

