

Autoroute with a grid of 10mil  
 Components on board with a grid of 0.025  
 Design rule check min track width 10mil  
 Design rule check min pad to via 40mil

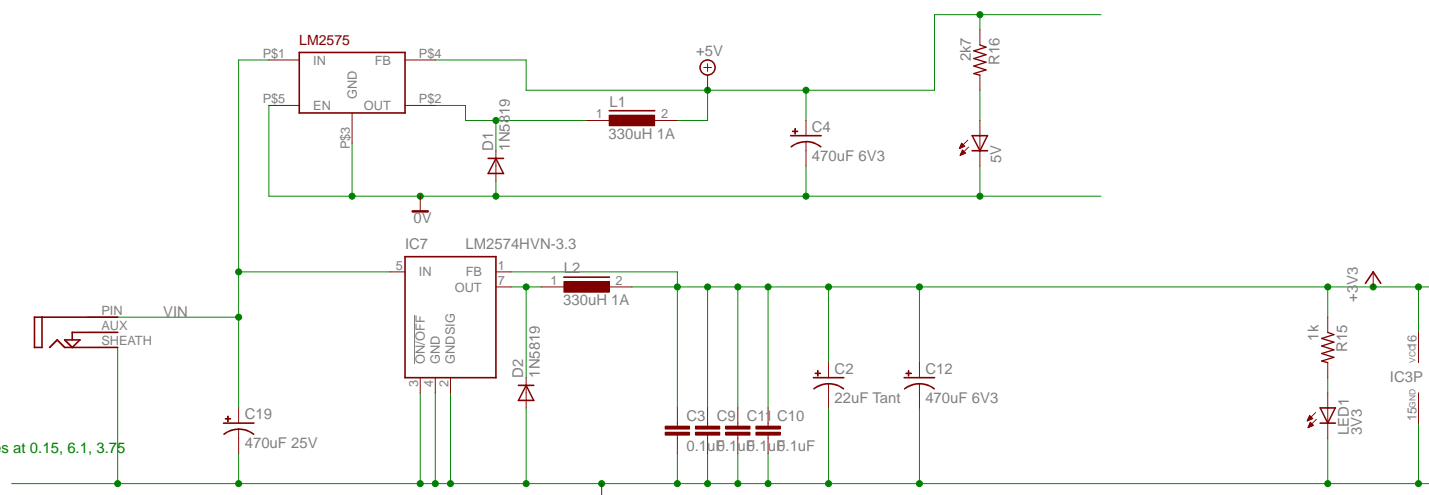

If installing prop plug leave out max3232 and associated components  
 As well as reset transistor and associated components

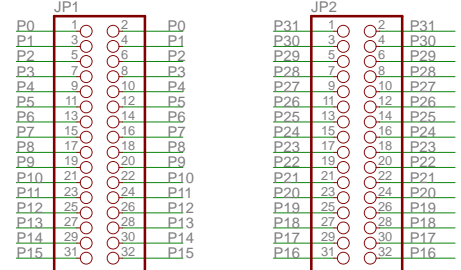
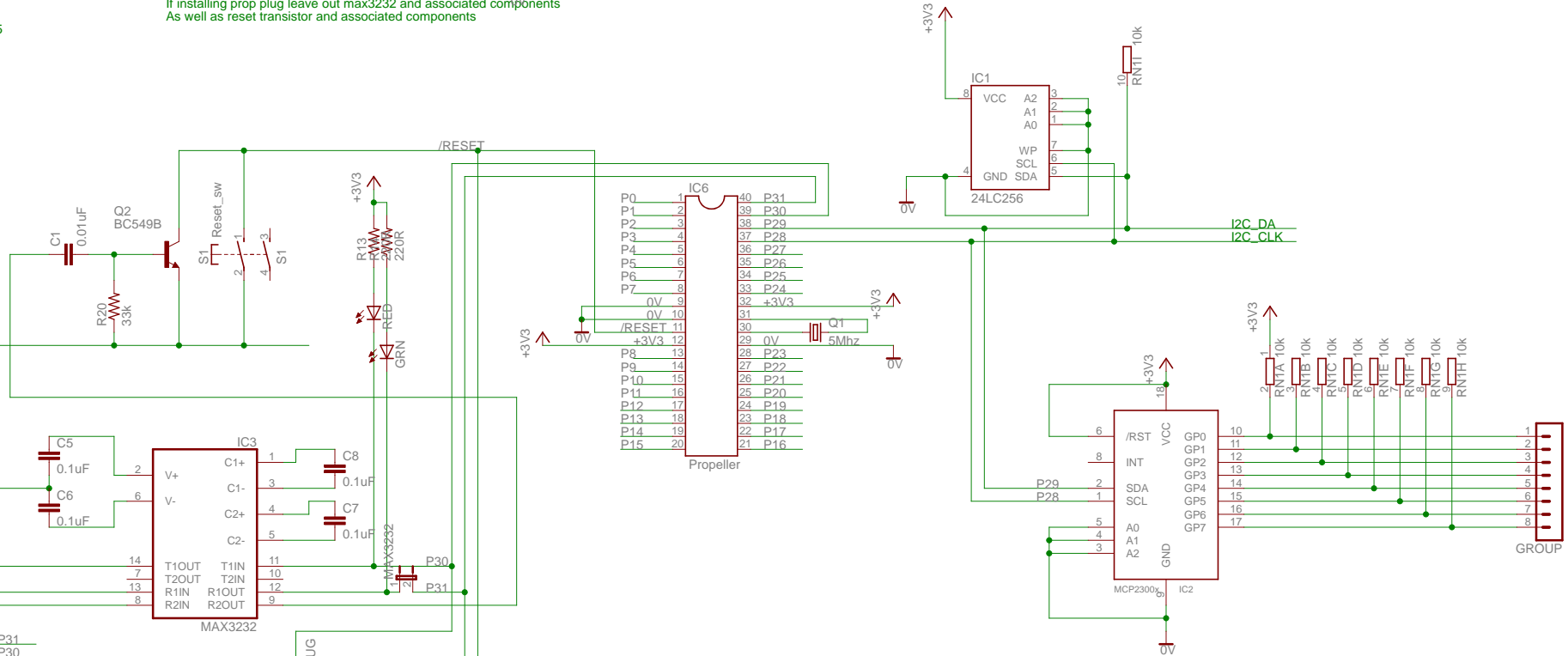
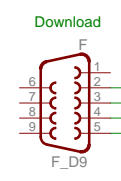
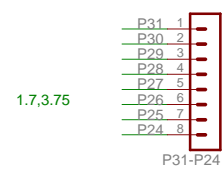
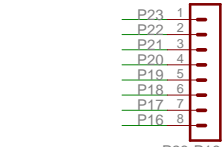
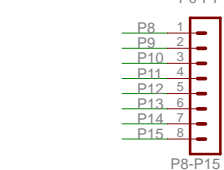
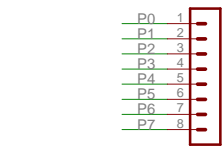
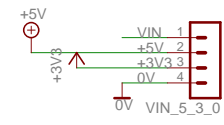
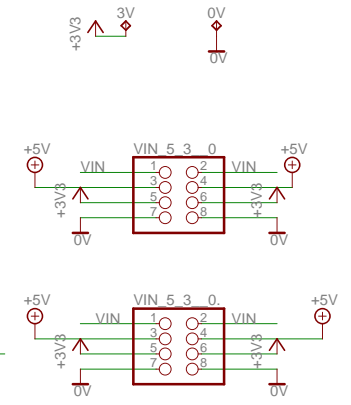

# Propeller Eurocard

<https://github.com/adafruit/Adafruit-Eagle-Library>  
 See the adafruit library for the MCP23008 part