

Propeller Eurocard Z80

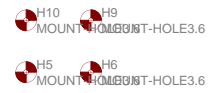

Default eagle board size 6.25x3.9. Holes at 0.15, 6.1, 3.75

Autoroute with a grid of 10mil
Components on board with a grid of 0.025
Design rule check min track width 10mil
Design rule check min pad to via 40mil

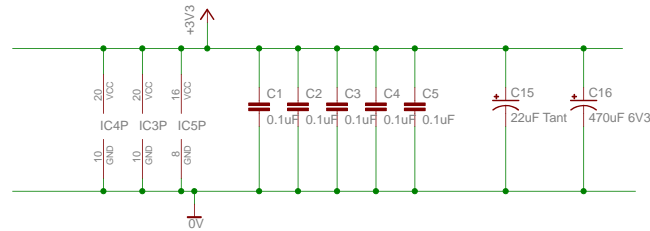
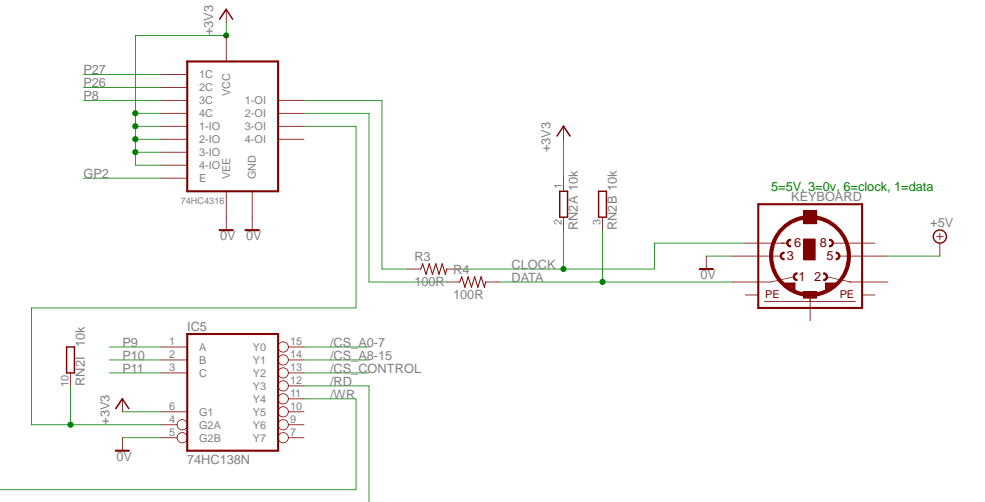

Position 0.15, 0.8 5.45

Use HCT rather than HC as a level H is more definite
Power these 3 chips from 5V

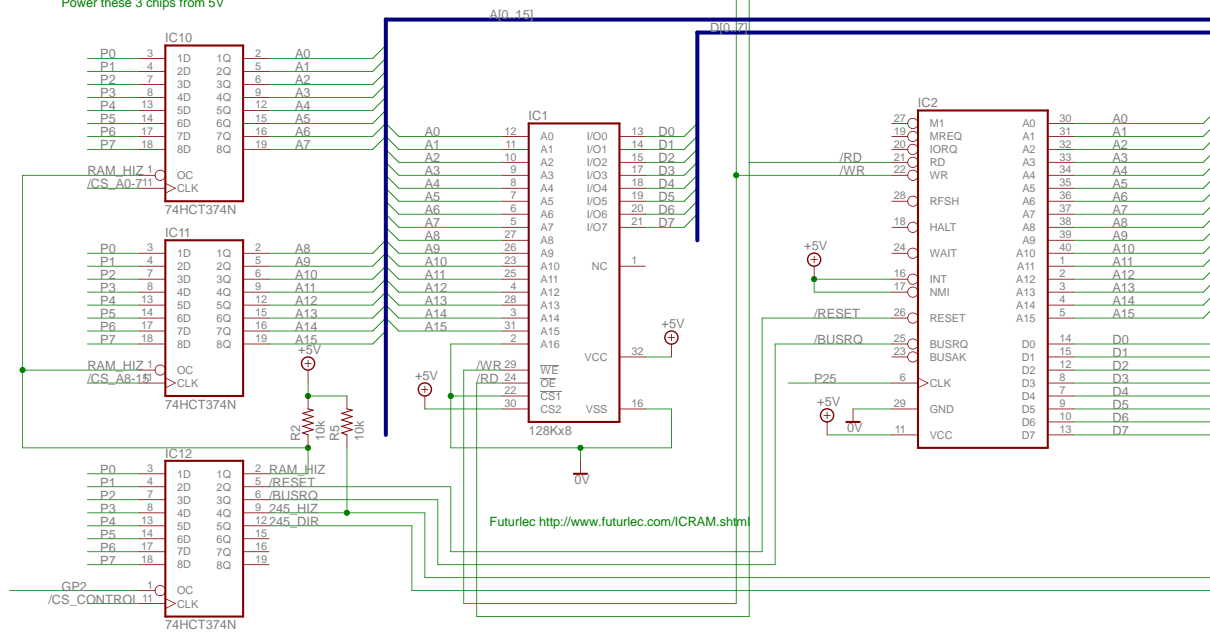

Futurelec <http://www.futurelec.com/ICRAM.shtml>

DIR H = A to B, L = B to A

This board is GP2

