

## Power Supply

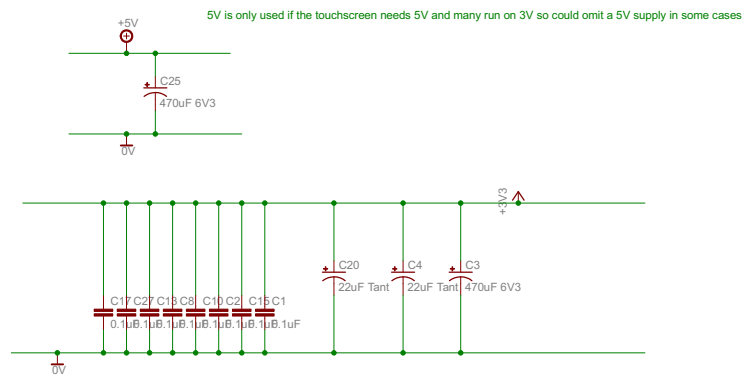

## Audio

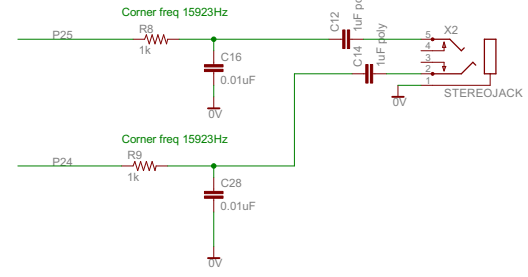

## Dual Propeller

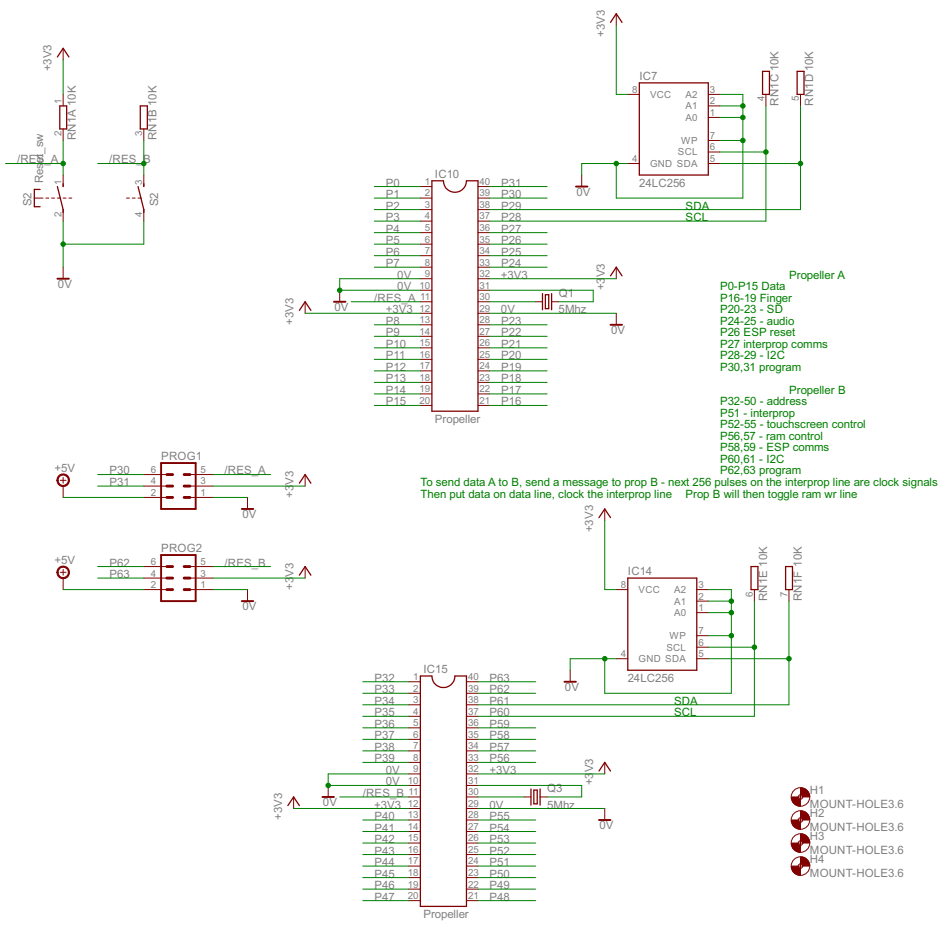

## ESP8266

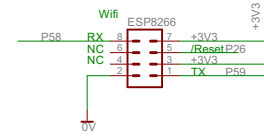

## Touchscreen module

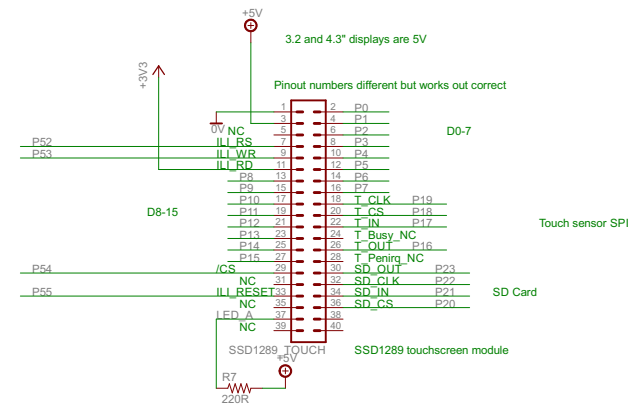

## Interprop Comms

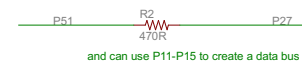

## 512k x 16 bit

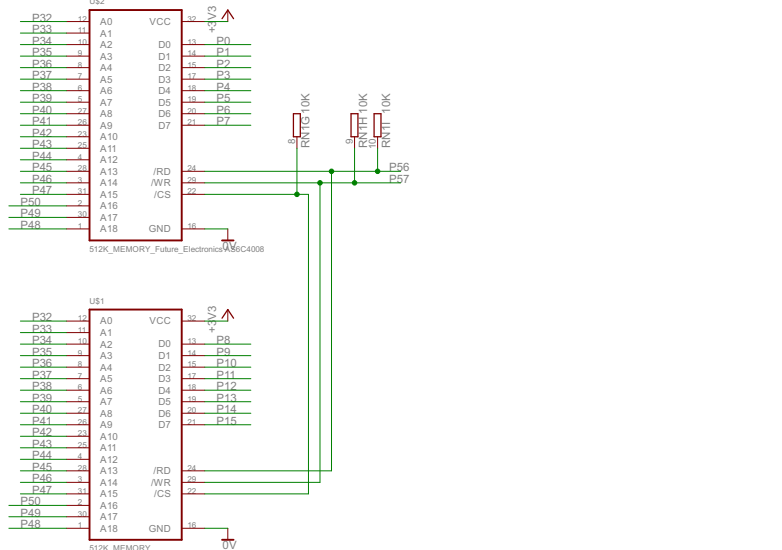

## I2C to analog and digital I/O

