

### Power Supply

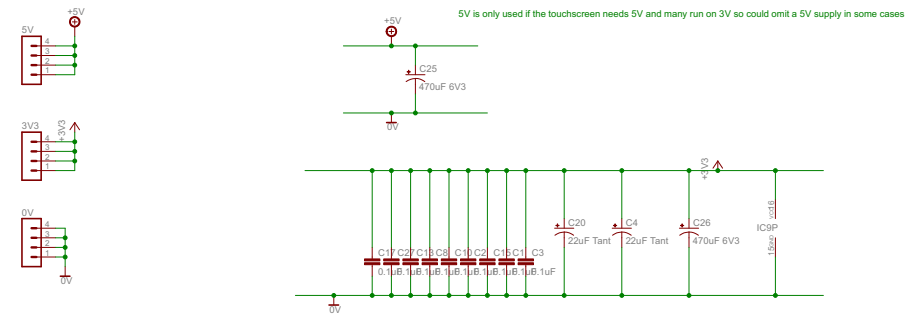

### Audio

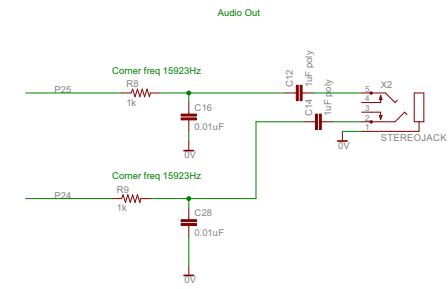

### Dual Propeller

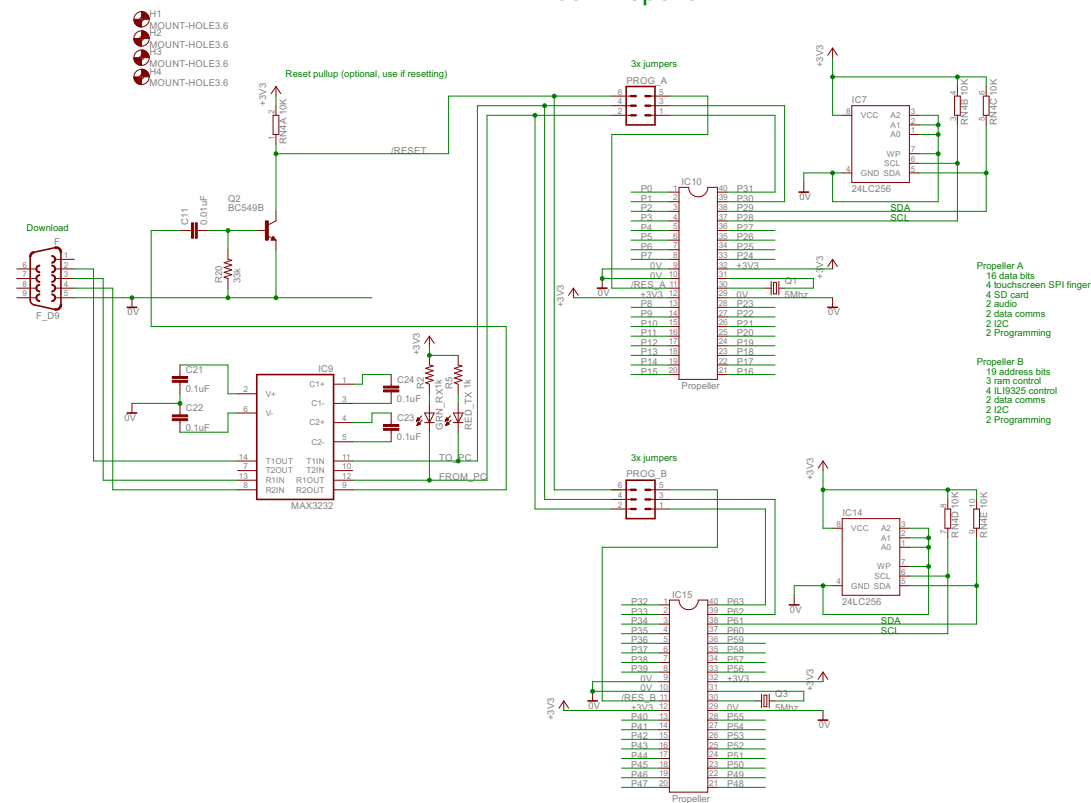

### Touchscreen module

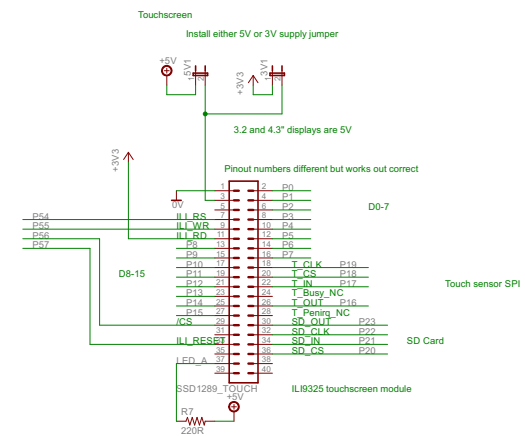

### Interprop Comms

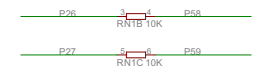

### 512k x 16 bit

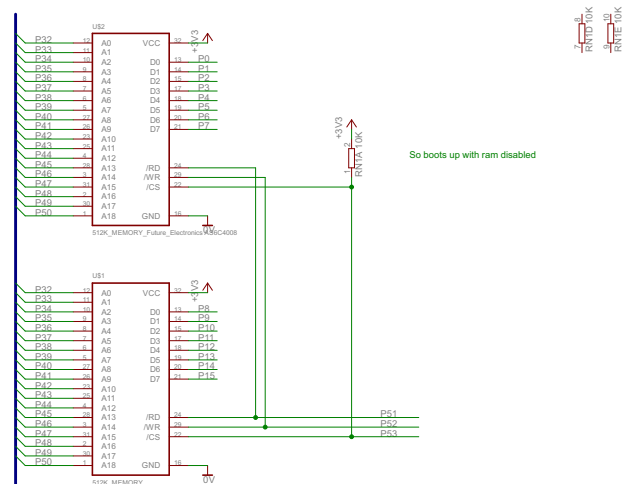

### I2C to analog and digital I/O