



# ABBot 1.0

## Advanced Boe Bot

Versions:

Version	Author	Date	Note
1.0	Vittorio Rossi	02.08.2009	First version

## 1. Project Goals

The main goal of this project was to develop an autonomous rolling robot, based on Parallax Boe-Bot, but using two boards and microcontrollers.

- It uses only standard, relatively cheap, Parallax parts (Board Of Education boards with Basic Stamp 2 microcontroller and several sensors and actuators).
- It can communicate with the user by:
  - Displaying information on its Serial LCD.
  - Talking through a TTS (Text To Speech) device.
- It may be given a goal to be reached:
  - Photophile (search for a place where lightning is above a certain level)
  - Photophobe (search for a place where lightning is below a certain level)
- It can move around by using wheels or the Boe-Bot Tank Tread Kit.
- It can detect obstacles by using an Ultrasonic Range Finder.
- It can avoid falling downstairs by using an Infrared Emitter and Receiver.
- It can stop and change direction when its horizontal or vertical inclination is too steep.
- It can detect temperature and humidity .
- It can display, at user request, all its sensors info.

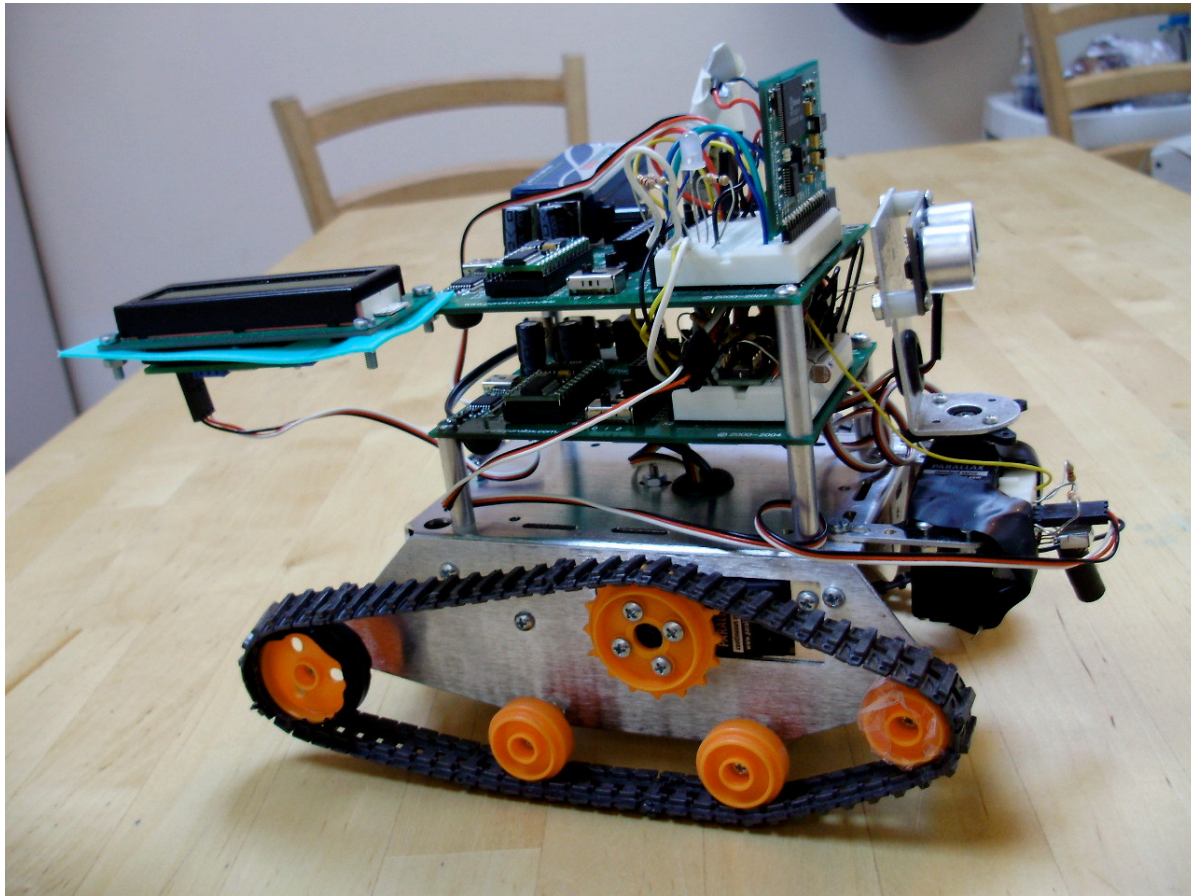



## 2. The two boards

This autonomous rolling robot uses two different boards, communicating with each other. Each board has some responsibilities.

By using two boards, we get some interesting results:

- Double memory space for Pbasic programs.
- Double I/O PINs
- Parallel processing (one board can process LCD display and TTS without affecting movements and sensors, which are managed by the second board).

At a very rough level, these two boards act respectively as the Central Nervous System and the Peripheral Nervous System of a human being, which are here briefly described (see [http://en.wikipedia.org/wiki/Nervous\\_System](http://en.wikipedia.org/wiki/Nervous_System)).

*The human nervous system can be described both by gross anatomy, (which describes the parts that are large enough to be seen with the naked eye), and by microanatomy, (which describes the system at a cellular level).*

*In gross anatomy, the nervous system can be divided into distinct organs, these being stations through which the neural pathways cross. These organs can be divided into two systems: the central nervous system (CNS) and the peripheral nervous system (PNS).*

*The central nervous system (CNS) is the largest part of the nervous system, and includes the brain and spinal cord. The spinal cavity holds and protects the spinal cord, while the head contains and protects the brain. The CNS is covered by the meninges, a three layered protective coat. The brain is also protected by the skull, and the spinal cord is also protected by the vertebrae.*

*The peripheral nervous system (PNS) is a regional term for the collective nervous structures that do not lie in the CNS. The bodies of the nerve cells lie in the CNS, either in the brain or the spinal cord, and the longer of the cellular processes of these cells, known as axons, extend through the limbs and the flesh of the torso. The large majority of the axons which are commonly called nerves, are considered to be PNS.*

That's why - even if the capabilities of this robot are obviously much limited, if compared with the biological nervous system - I've called the two boards respectively CNS and PNS.

Here is an overview of the CNS and PNS structures and functions:

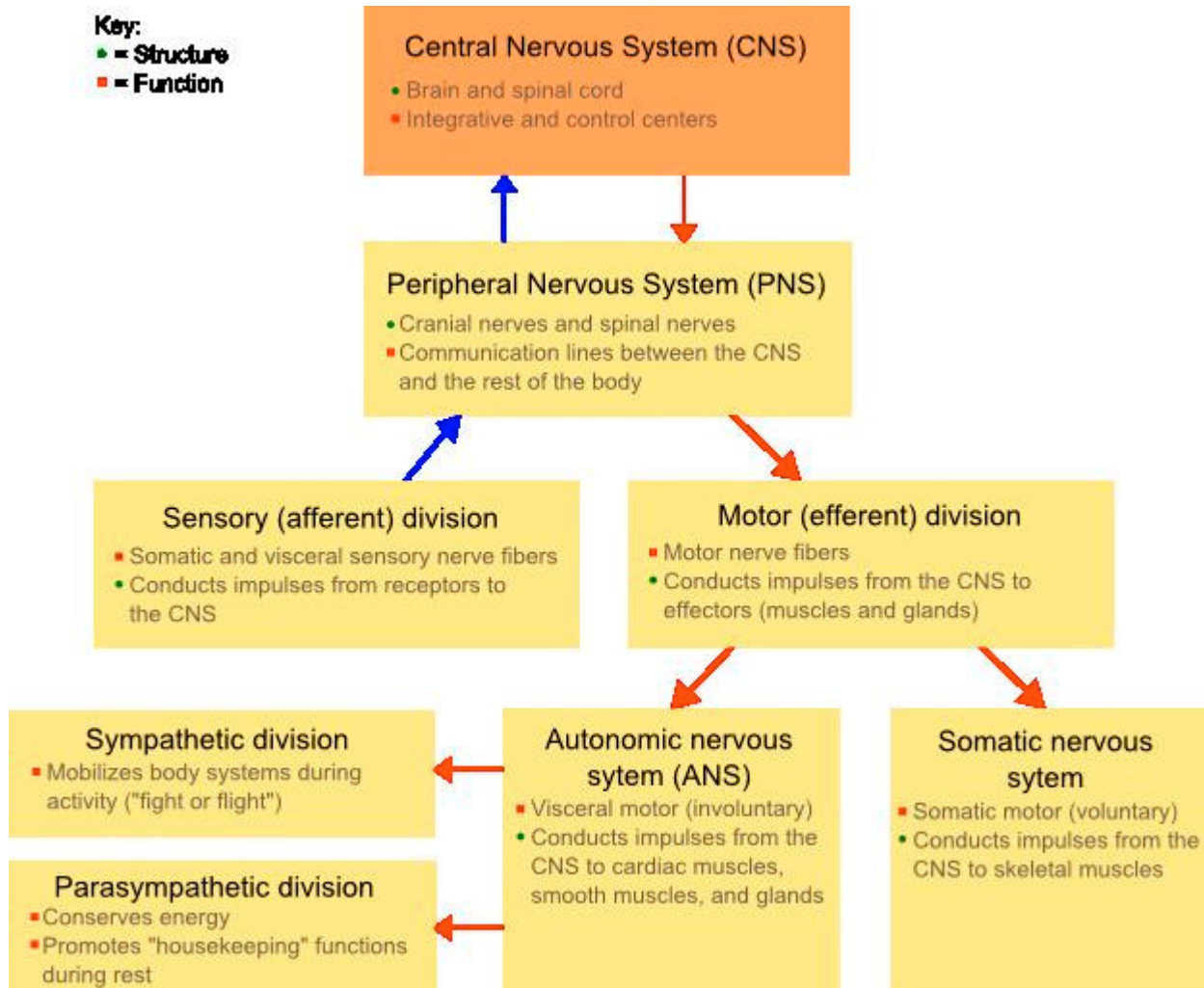

### 3. Hardware components

Parallax Boe-Bot, with two BOE boards (with a Basic Stamp 2 microcontroller on each) and a Tank Tread Kit.

#### CNS board:

' -----[ LEDs ]-----

' 1 Bicolor (Green/Red) LED

' 1 Resistor (470 ohm)

' -----[ Serial LCD ]-----

' 1 Parallax Serial LCD Backlit 2 rows x 16 char (Item code 27977)

' -----[ Emic TTS ]-----

' 1 Emic Text-to-Speech SIP Module (Female) (Item code 30006)

#### PNS board:

' -----[ Light Detector ]-----

' 2 Photoresistors

' 2 Capacitors 0,01 uF (103)

' 2 Resistors (220 ohm)

' -----[ Ping Distance Detector ]-----

' 1 Ping

' 1 Standard Servo mounted on bracket

' -----[ Accelerometer ]-----

' 1 Memsic Accelerometer

' 2 Resistors (220 ohm)

' -----[ Speaker ]-----

' 1 Piezo speaker

' -----[ Temperature/Humidity Detector ]-----

' 1 Sensirion SHT11

' -----[ InfraRed Detector ]-----

' 1 IR detector

' 1 IR LED

' 1 Resistor 220 ohm

' 1 Resistor 1K ohm (in order to be enough nearsighted to detect stairs;

' the emitter must be oriented at about 45°)

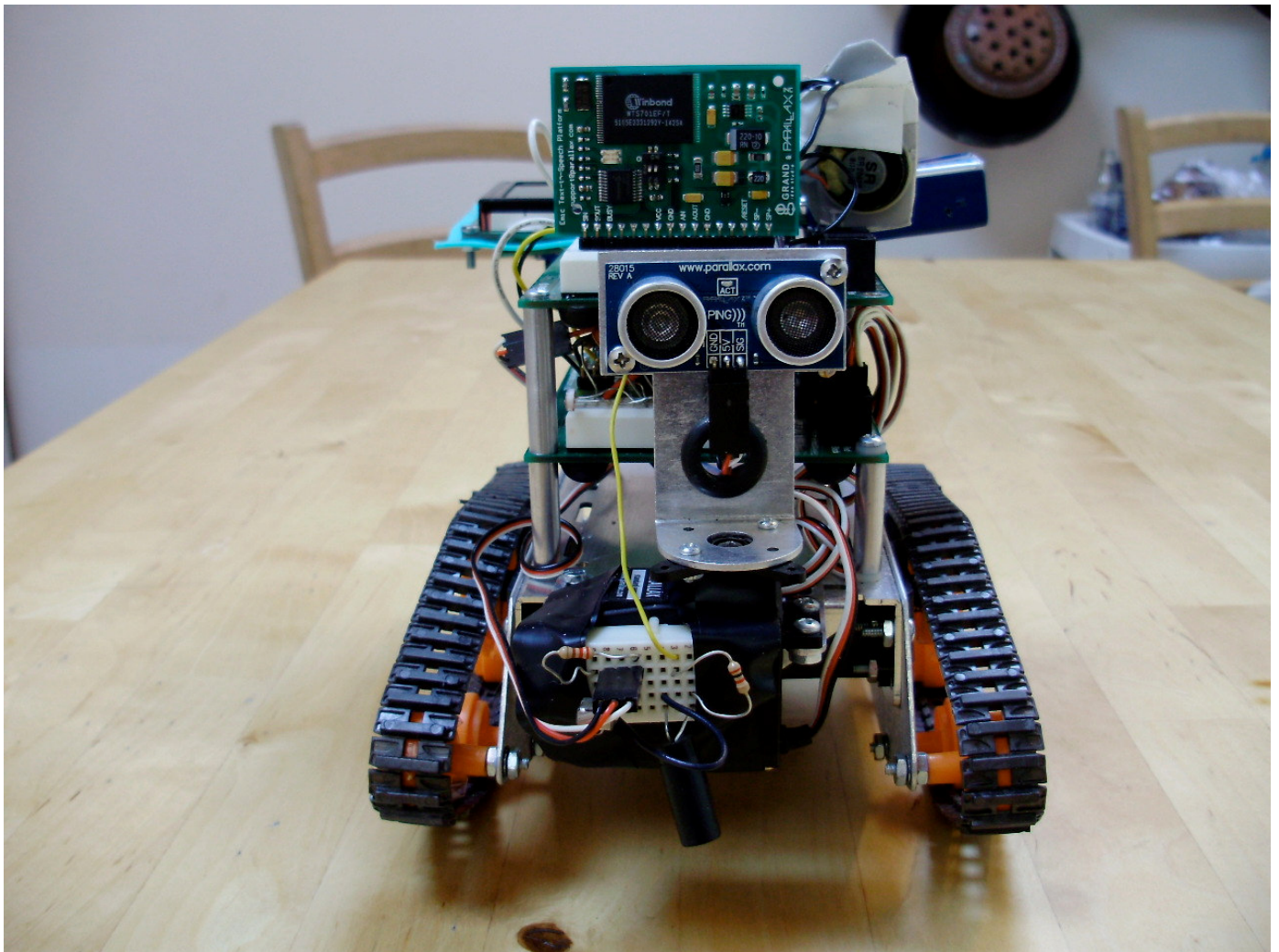

For a more detailed example of its behaviour, see the video at:

<http://www.youtube.com/watch?v=VtskL6gn0k0>

<http://www.youtube.com/watch?v=g3RbAFsCa0E>

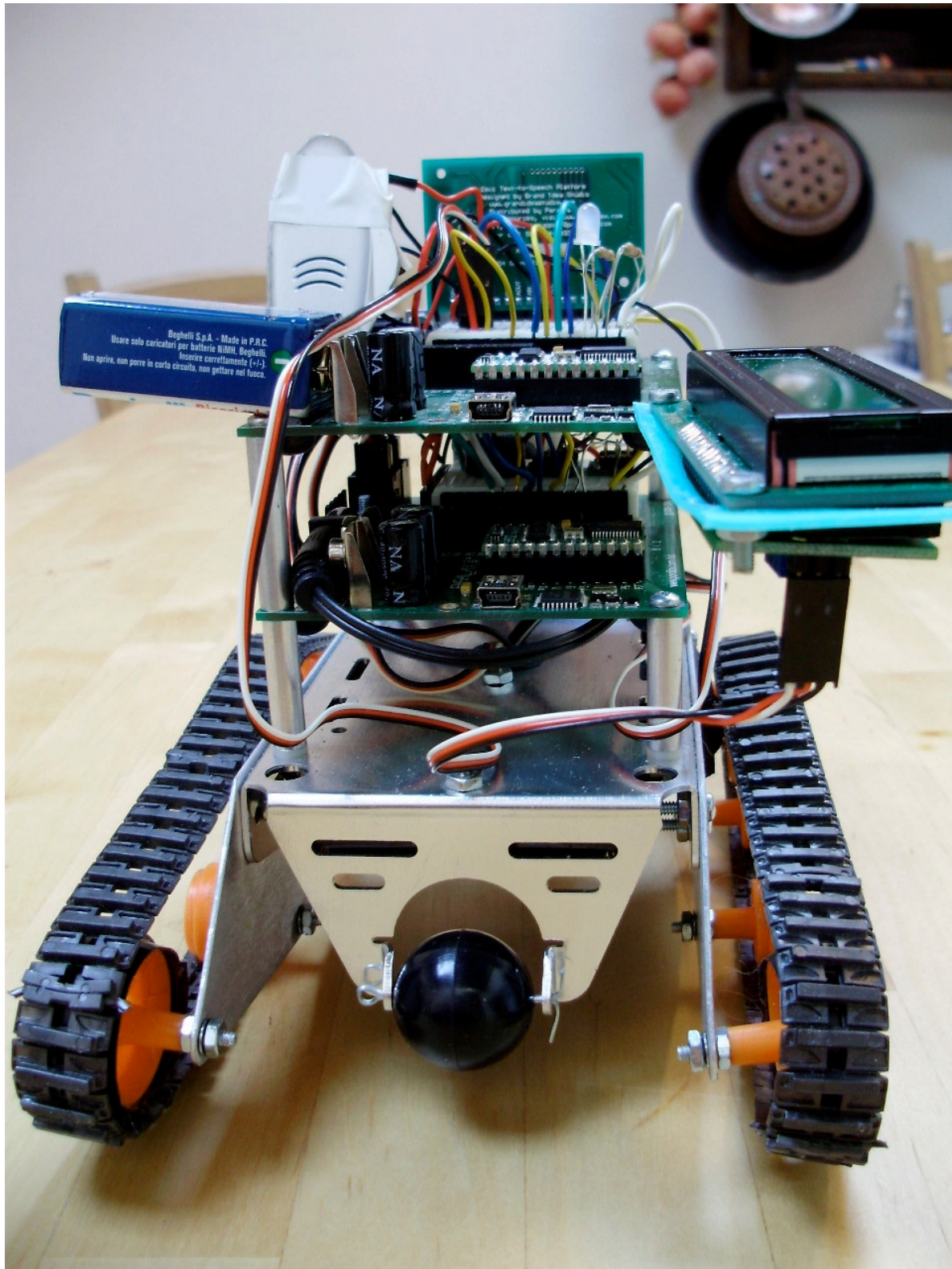

## 4. Communication Protocol

Communication between CSN and PSN is based on input/output commands like the following:  
 SEROUT IOPin\FCPin, IOBaud, 5000, NoConnection, ["C2P", DEC IOCommand, CR, DEC IOData, CR]

SERIN IOPin\FCPin, IOBaud, 1000, NoConnection, [WAIT("P2C"), DEC IOCommand, DEC IOData]

where:

- "C2P" and "P2C" mean respectively "CNS to PNS" and "PNS to CNS" so they determine who is the sender and who is the target of the communication. This might come handy in case you add more boards.
- IOCommand (byte) is the command sent/received
- IOData (word) is the optional data to be exchanged.

## 5. Connections Diagrams

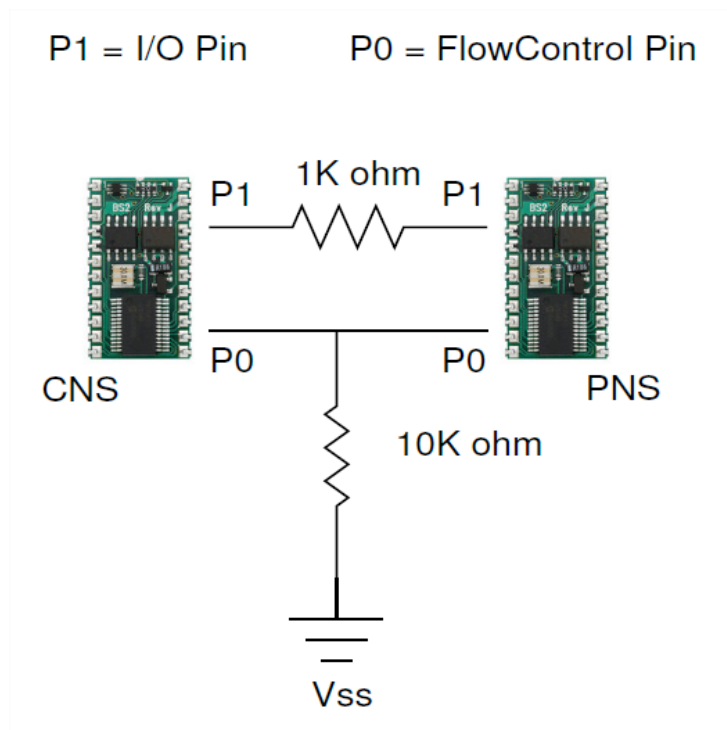



# CNS

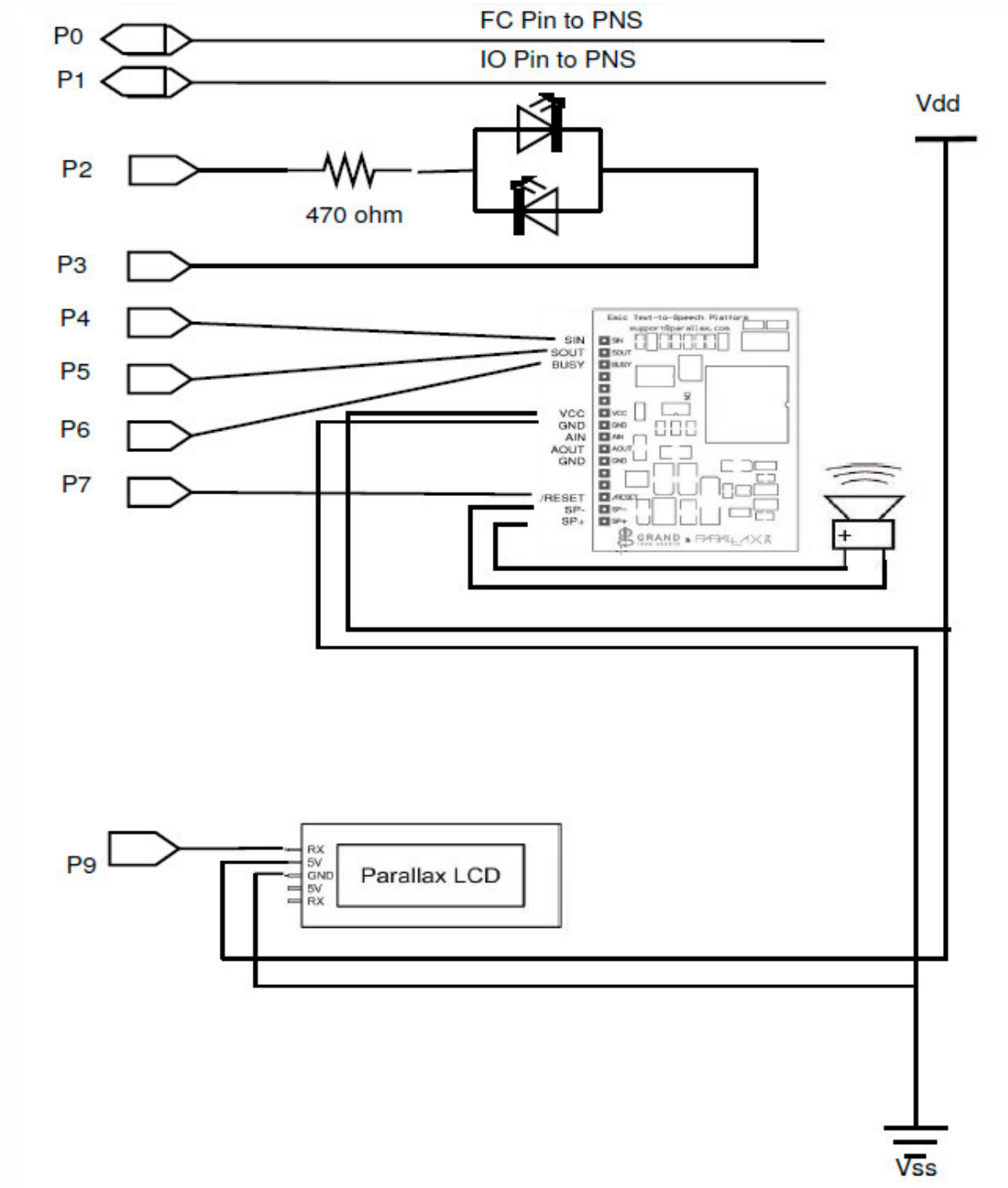

# PNS

