

Chapter 7: Basic Sine Wave Measurements

SINE WAVE EXAMPLES

Figure 7-1 shows two cycles of a sine wave. Examples of this gradual up/down pattern can be seen in waves in a pool or at sea, in the air pressure variations from musical instruments playing notes, in radio and TV signals, and the voltages supplied by AC electrical outlets.

Figure 7-1: Sine Wave – Two Cycles

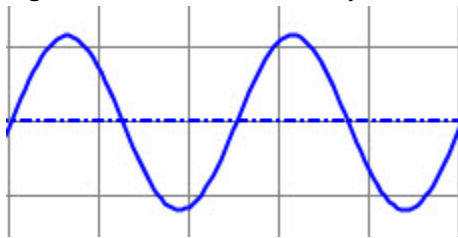

7

This chapter introduces basic sine wave measurements using signals that create tones and musical notes as examples. Many signals contain more than one sine wave component, like musical chords, phone tones, and even binary on/off signals. So, this chapter also introduces the spectrum analyzer, a diagnostic tool you can use to display a signal's sine wave components. Many circuit tests involve comparing a sine wave supplied to a circuit's input against the one at its output. So techniques for supplying a sine wave to a circuit and comparing the properties of the input and output signals are also introduced.

ACTIVITY #1: SINE WAVE AMPLITUDE AND FREQUENCY TESTS

When a musical note is played by an instrument like a guitar, the guitar string's vibrations cause air pressure variations. When a speaker plays a musical note, it converts electrical signals into vibrations that cause pressure variations. Regardless of whether it's an actual instrument or a speaker playing the note, the eardrum senses the air pressure variations and forwards those signals to the brain via nerve connections. Then, our brain processes that information and we experience it as a musical note. Two properties of a note are volume and pitch. Volume is how loud the note sounds. Pitch is usually described in terms of high or low. For example, a bass guitar tends to play lower pitched notes, while a normal guitar plays higher pitched notes.

Musical notes are sine waves at specific frequencies, and you will experiment with them in the next activity. This activity will use more arbitrary frequencies, so instead of musical notes, they will just be “tones”. The PropScope’s function generator will be configured to apply sine waves to a piezospeaker, and its oscilloscope will be used to monitor them. With this setup, you’ll be able to “see” the sine waves with the oscilloscope at the same time that you “hear” the result played by the speaker.

The function generator has settings that allow you to control a sine wave’s amplitude and frequency. So in this activity, you will vary a sine wave’s amplitude and view its height change in the oscilloscope as you hear the speaker’s volume change. You will also vary the frequency and view the sine wave’s cycle width change in the oscilloscope as you hear the speaker tone’s pitch change.

Audio Tones Parts List

- (1) Piezospeaker
- (misc) Wires

Audio Tones Circuit

The PropScope’s function generator feature can be used to generate sine waves with certain amplitudes and frequencies, and those sine waves can be played by a speaker. Figure 7-2 shows a schematic and Figure 7-3 shows an example wiring diagram of the test circuit. The function generator sends sine wave voltages to the circuit, and the speaker makes it possible to “hear” to them as tones. The CH1 probe is for measuring the signals, and the Oscilloscope makes it possible to “see” them as sine waves.

- ✓ Disconnect the probe with the red marker band from the PropScope’s CH2 BNC port, and connect it to the DAC CARD’s function generator output. (For detailed instructions, see the Set DC Voltages with the PropScope’s DAC CARD section starting on page 43.)
- ✓ If the piezospeaker has a sticker covering it, remove that sticker.
- ✓ Build the circuit shown in Figure 7-2 using the wiring diagram in Figure 7-3 as a guide.

Comment [AL69]: Remove extraneous reference to DAC CARD when not needed.

Comment [AL70]: Update labeling in chapter 1. Indicate the ports of the DAC CARD and use Function Generator as the name of the DAC output.

Comment [AL71]: Update this section’s name to be shorter and more useful elsewhere in the book.

Figure 7-2: Audio Tones Schematic

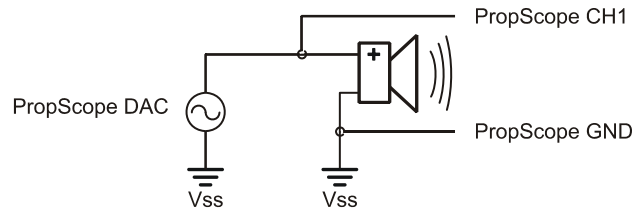

Comment [AL72]:
 Eliminate any use of schematic references to DAC CARD that look like the PropScope CH1/2 labels.

 Update any DAC CARD function generator output with the appropriate schematic symbol.

Figure 7-3: Wiring Diagram for Figure 7-2

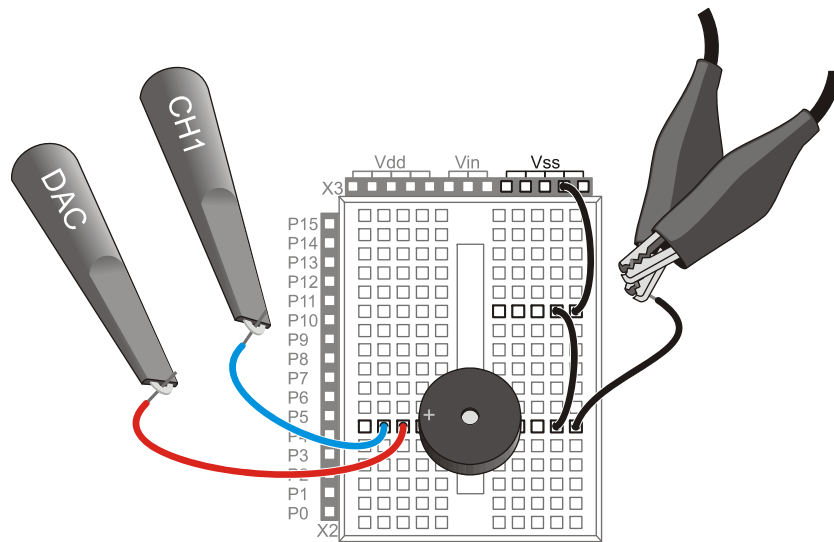

7

Audio Test Measurement Settings

Figure 7-4 shows the PropScope’s Generator panel configured to make the function generator output a sine wave with a frequency of 2.5 kHz, a peak-to-peak voltage of 3 V, and a DC offset of 0 V. This signal should cause the piezospeaker to make an audible tone. The oscilloscope screen makes the tone visible as well as audible. Remember that the oscilloscope screen is a plot of voltage vs. time, so what you see in the display is a graph of the voltage applied to the speaker as it varies with time in a sine wave pattern.

- ✓ Set the dials to: Horizontal = 100 μ s/div, Vertical CH1 = 1 V/div, and CH2 = 1 V/div.

- ✓ Vertical coupling switches: CH1 = DC, CH2 = Off.
- ✓ Optional: Drag the CH1 ground line up/down to position it about 2 ½ voltage divisions above the time scale so that it matches Figure 7-4.
- ✓ Trigger tab switches: Mode = Continuous, Edge = Rise, Level = Auto, and Source = CH1.
- ✓ Generator panel: Function switch = Sine, Frequency = 2500, Amplitude = 3, and Offset = 0.
- ✓ Click the Generator panel's Generate button make the DAC CARD start transmitting the signal.
- ✓ Make sure you can hear the speaker making an audio tone. Also make sure you can see a sine wave similar to the one in Figure 7-4 in your oscilloscope screen.
- ✓ Try using the Run button (not the Generate button) to freeze the signal and turn the function generator signal (sound) off.
- ✓ Click the Run button again to restart the sound and the display.

Comment [AL73]: To-do:
Make sure Function switch is used throughout the text.

Figure 7-4: Function Generator and Oscilloscope Settings

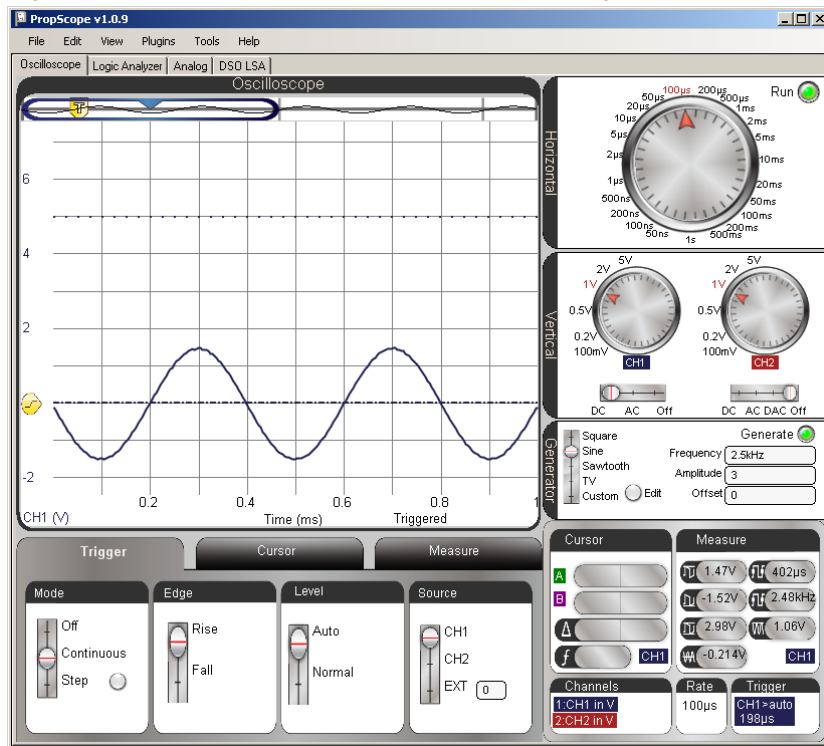

**Run button vs. Generate button.**

For this activity, the Run button is better than the Generate button for stopping the tone because it freezes the display before it stops the PropScope and DAC CARD. So it turns the sound off while preserving the last sine wave that was displayed in the oscilloscope screen. So, you'll be able to turn the sound off and continue to examine the sine wave.

If you use the Generate button instead, it does toggle the function generator on/off, which will stop the tone too. However, the oscilloscope will keep running, and there's a chance that the signal activity as the function generator switches off will trigger the display. If that happens, your sine wave will be replaced by some miscellaneous switching activity.

Test Amplitude's Effect on Volume

A sine wave's amplitude can be measured in several different ways. Figure 7-5 shows two examples: peak-to-peak voltage (V_{pp}) and peak voltage (V_p). With an oscilloscope, peak-to-peak amplitude is the voltage difference between the tops of a sine wave's peaks (V_{max}) and the bottoms of its valleys (V_{min}). The PropScope displays V_{max} , V_{min} , and V_{pp} for a given channel in its measure display.

7

Another common amplitude measurement is peak voltage (V_p), which is just the height of a sine wave's peaks measured from the half way point. Peak amplitudes are more common in equations that describe sine waves. In contrast, peak-to-peak amplitudes are more common in oscilloscope measurements. If you ever need the peak amplitude measurement for an equation, just take the peak-to-peak measurement from your oscilloscope and divide by 2.

Figure 7-5: Peak-to-Peak vs. Peak Amplitude

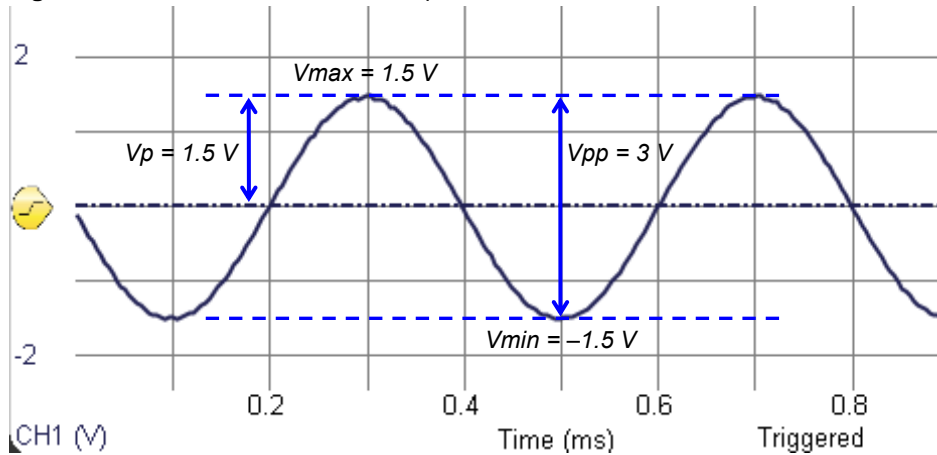

$$V_{pp} = V_{max} - V_{min}$$

$$V_p = V_{pp} \div 2$$

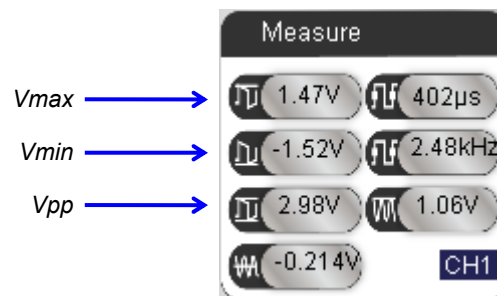

Larger sine wave amplitudes result in louder piezospeaker volumes; smaller amplitudes result in quieter speaker volumes. Figure 7-6 shows how a cycle of the sine wave looks at three different amplitudes. As the amplitude increases, the sine wave's height in the oscilloscope increases, and so does the volume. Try these adjustments to the signal's amplitude:

- ✓ If your tone and display are paused, click the On button again to resume viewing the live signal and playing the tone.
- ✓ Type 1 into the Generator panel's Amplitude field and press enter.
- ✓ Listen to volume from the speaker and make a note of the sine wave's amplitude in the Oscilloscope screen.
- ✓ Repeat by entering values of 2 and then 3 into the Generator panel's Amplitude field. The tone should get a little bit louder with each adjustment. Listen to the volume and make a note of the Oscilloscope amplitude after each adjustment.

Figure 7-6: Signal Amplitude Compared to Speaker Volume

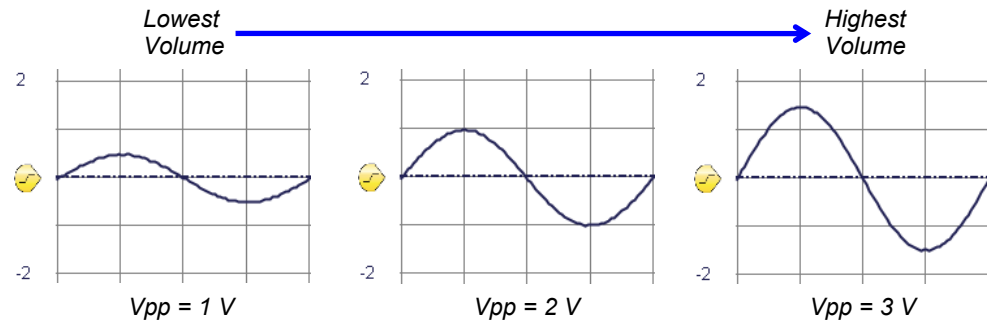

Test Frequency's Effect on Pitch

Chapter 3, Activity #3 introduced frequency as the number of times a signal repeats itself per second and period as the signal's cycle time. Figure 7-7 indicates the start and end of a single sine wave cycle. The start of a sine wave's cycle is the point where it passes upward through the half way point on its way from valley to peak. The cycle time can be measured to determine the sine wave's period (T). Then, its frequency (f) can be calculated with $f = 1 \div T$. The PropScope's Measure display also shows the sine wave's measured period and frequency values for a given channel. In this case, the period can also be measured by counting the number of $100\ \mu\text{s}$ divisions in a cycle. If the sine wave is exactly 2.5 kHz, one cycle should span exactly four $100\ \mu\text{s}$ time divisions.

7

Figure 7-7: Period of One Sine Wave Cycle

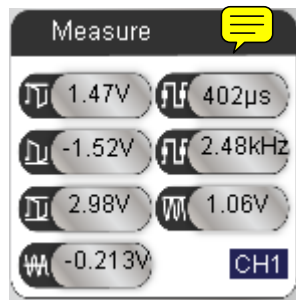
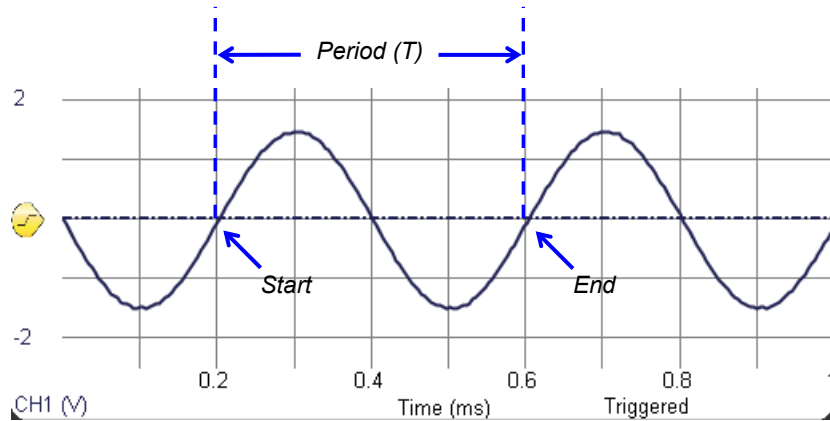

Frequency:
 $f = 1 \div T$

$$\begin{aligned}
 f &= 1 \div 400 \mu\text{s} \\
 &= 1 \div 0.0004 \text{ s} \\
 &= 2500 \text{ Hz} \\
 &= 2.5 \text{ kHz}
 \end{aligned}$$

Figure 7-8 shows how the frequency relates to the tone’s pitch. A higher frequency results in a higher pitched speaker tone. It also results in a more compressed waveform on the oscilloscope screen. A lower frequency results in a lower pitched tone, and it also results in a less compressed or more stretched out waveform on the oscilloscope screen.

- ✓ Set the Generator panel’s Amplitude to 3 Vpp.
- ✓ Type 2200 into the Frequency field and press enter.
- ✓ Listen to the pitch of the tone the speaker makes.
- ✓ Make a note of the waveform’s period as well as how wide it looks in the Oscilloscope.
- ✓ Repeat with frequency settings of 2400, 2600, 2800, and 3000.
- ✓ Try entering the five frequencies in a fairly rapid succession as you listen carefully to identify the increase in pitch.

Figure 7-8: Pitch Compared to Frequency and Period

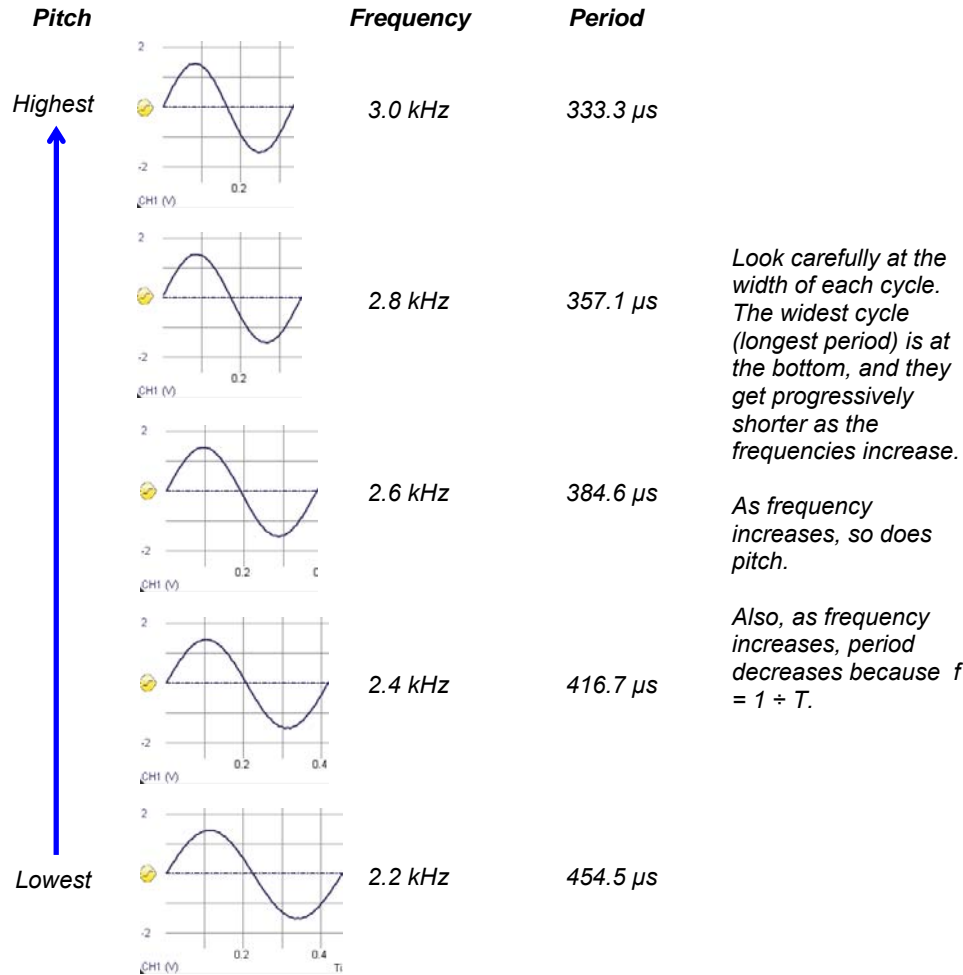

7

In terms of $f = 1 \div T$, the highest frequency waveform has the shortest period (time between signal repetitions). That again is because period is the reciprocal of frequency: $T = 1 \div f$. Whenever f gets larger, T gets smaller, and vice-versa.



The PropScope's Frequency field accepts frequencies from 1 Hz to over 1 MHz in increments of $1/10^{\text{th}}$ Hz.

If the sine wave gets too compressed or too stretched out to fit well in the oscilloscope screen, just adjust the Horizontal dial's time/division setting. Decrease it for higher frequencies to uncompress the waveform's display, or increase it for lower frequencies to get a waveform to fit that would otherwise look stretched.

Your Turn: Test the Piezospeaker's Frequency Response

You may have noticed that the tone gets slightly louder as the frequency increases. That's because even though amplitude controls volume, certain speakers play certain frequencies louder than others. All speakers have natural filtering properties that depend on their electromechanical design. The woofer, midrange and tweeter names for speakers indicate that they play particular frequencies louder and clearer than the others. A woofer plays low frequencies, and it would be difficult to hear high notes played through it. A tweeter plays high frequencies, making it difficult to hear the low notes. The midrange excels with middle notes. You can hear the low and high notes through a midrange speaker, but they are quieter. With all three speakers working together, their signals add up to make a nice full sound.

When testing the frequency response of a speaker, keep the amplitude of the sine wave the same. That way, you can determine how the speaker responds to frequencies. The signal will be the same amplitude for each frequency. So, if one tone is louder than the next, it's a property of the speaker. If a tone sounds really loud, it may be because the speaker is designed to vibrate at that frequency. Kind of like when you ring bells of different sizes and shapes. ~~Each one has mechanical properties that resonate at a particular frequency. This natural frequency is called the resonant frequency.~~ The piezospeaker in your Understanding Signals kit is designed with a resonant frequency for smoke alarms, so it sounds louder at higher frequencies.

- ✓ Set the Generator panel's Amplitude to 3 V, and make sure to press Enter with each adjustment to update the function generator's output.
- ✓ Try 1, 2, 3, 4, 5, 6, and 7 kHz.

Can you make it any louder? Hint: the resonant frequency should be ~~half-way~~ between two of the frequencies you have already tested.

ACTIVITY #2: DC OFFSET TESTS

DC offset is useful for certain designs and detrimental to others. A useful example would be a signal that is given some DC offset so that every cycle crosses the BASIC Stamp's 1.4 V logic threshold. A detrimental example would be giving a normal audio speaker a sine wave with DC offset. They are designed to receive signals with 0 V_{DC} offset.

In this part of the activity, we'll add some DC offset to the signal applied to the piezospeaker. The Understanding Signals Kit's piezospeaker is not the same as a normal audio speaker; it can receive signals with DC offset. From the audio standpoint, there will be little or no difference in the sound, but the signal will look different in the oscilloscope screen.



WARNING Only use a piezospeaker here. **Do not** try adding DC offset to audio speaker signals. Audio speakers have wound wire coils built-in. These coils have very low resistance compared to piezospeakers. DC voltage could result in excessive current demands on the PropScope and its USB port power supply.

7



The element in a piezoelectric speaker changes shape with applied voltage, and when the voltage oscillates rapidly, the piezo element's vibrations create the tones. This process takes only small amounts of current.

In an audio speaker, an electromagnet acts on a magnet attached to a paper cone to make it vibrate. The oscillating voltage applied across the electromagnet's coil results in oscillating current through the coil. This oscillating current through the coil creates an oscillating magnetic field that acts on the magnet attached to the paper cone.

Auto Trigger Follows Average Voltage (DC Offset)

Since the Trigger tab's Level switch is set to Auto, the oscilloscope automatically adjusts the Trigger Voltage Control to follow the waveform's average voltage. Remember that DC offset and average voltage are one and the same. So when you set the Generator panel's Offset to a value, the DC offset = average voltage changes, and the Trigger Voltage Control follows it. Up to this point, the Generator panel's Offset has been set to 0 V, which is where the Oscilloscope has been automatically positioning the Trigger Voltage Control.

- ✓ Verify that the Trigger Voltage Control's level is 0 V. It should be automatically positioned to the left of the Ground line.
- ✓ Change the Generator panel's Offset from 0 to 2.35 V and press enter.
- ✓ Verify that the waveform's average voltage changes to 2.35 V.

- ✓ Point at, but do not click the Trigger Voltage Control. (See Figure 7-9.) Verify that the Trigger Voltage Control has automatically repositioned to approximately 2.35 V.

Figure 7-9: Trigger Auto Level Adjusts with DC Offset

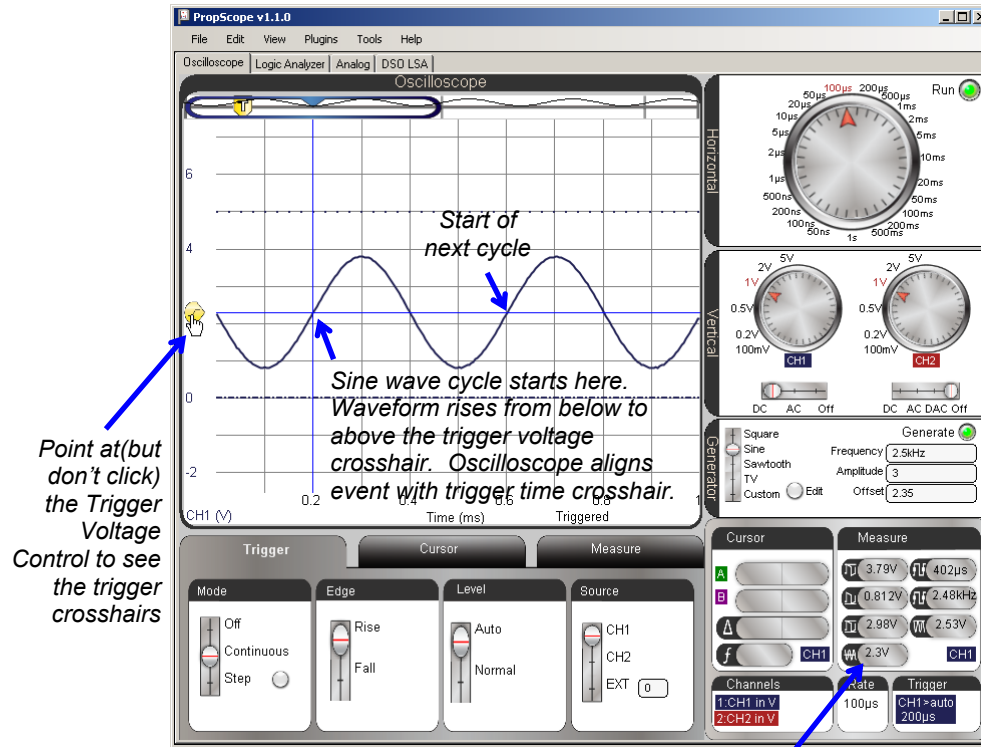

The Trigger tab's Level switch in Figure 7-9 is set to Rise. So, the Oscilloscope aligns a point where the sine wave rises through the 2.35 V Trigger Voltage crosshair with the Trigger Time crosshair. For a sine wave, this is the start of its cycle. You can see part of a second cycle in the screen, starting four time division lines to the right of the trigger event.

- ✓ Try changing the Edge switch in the Trigger tab from Rise to Fall. The voltage should now fall through the trigger crosshair intersection instead of rising through it.

- ✓ Restore the Trigger tab's Edge switch to Rise.

If the Trigger tab's Level switch is set to Normal, it means that you will manually adjust the Trigger Voltage Level control. If the waveform's DC offset or amplitude changes enough so that the signal doesn't cross the Trigger Voltage level, the oscilloscope screen will not refresh. There may still be signal activity, but it will not be displayed on the Oscilloscope screen. Try this.

- ✓ Set the Generator panel's Offset back to 0 V. The Trigger Voltage Control should automatically reposition to 0 V.
- ✓ Move the Trigger tab's Level switch to the Normal setting.
- ✓ Change the Generator panel's Offset back to 2.35 V.



At this point, the sine wave should still appear to have a 0 V offset, and a red status warning should appear in the lower right of the Oscilloscope screen: **Wait for Trigger**. That's because the waveform never crosses the 0 V trigger voltage, so the display does not update.



- ✓ Now, manually move (click, hold and drag) the Trigger Voltage Control up to 2.35 V.

The sine wave should reappear, displayed at the correct level.

- ✓ Before continuing, set the Trigger tab's Level setting back to Auto.

Offset and Amplitude Tests

Up to this point, your PropScope is displaying a 3 Vpp sine wave with a 2.35 V offset. The sine wave extends to 3.85 V peaks and 0.85 V valleys. Your signal is currently in the larger of two function generator voltage ranges: 0 to 4.7 V, and the waveform's DC offset is currently 2.35 V, which is in the middle of that range. So, you could increase the Generator panel's Amplitude setting all the way to 4.7 Vpp. This is a larger amplitude than any of the tests in the -1.5 to +1.5 V range, where the maximum amplitude was 3 Vpp.

- ✓ Try setting the Generator panel's Amplitude to 4.7 Vpp.
- ✓ Compare that to Amplitude = 3 Vpp. Can you hear the volume difference? Can you see the difference in the Oscilloscope screen as well?



With 4.7 V_{pp} of amplitude, there is no room to experiment with DC offset adjustments. With 3 V_{pp} of amplitude and 2.35 V_{DC} of offset, there is some room to experiment, but not much. 3 V_{pp} of amplitude makes it possible to adjust the DC offset 0.85 V up or down without exceeding the function generator's 0 to 4.8 V limits. By changing the Amplitude to 1 V_{pp}, you'll have more room to adjust the offset. In fact, 1 V_{pp} can fit into either the = -1.5 to +1.5 V or 0 to 4.8 V ranges. So, you'll be able to adjust the sine wave's offset to anywhere in the -1 V to +4.2 V range.

- ✓ Change the Generator panel's Amplitude to 1 V.
- ✓ Enter each of these DC offset values to the Generator panel's Offset field: -1, 0, 1, 2, 3, 4, and 4.2 V.

Keep in mind that the peak amplitude (which is ½ the peak-to-peak amplitude) is the total excursion above and below the sine wave's DC offset. So with a 1 V_{pp} amplitude, when you change the Generator panel's offset to -1 V, its voltage oscillates from 0.5 V above that level to 0.5 V below it. That's why the DC offset can be adjusted clear down to -1 V, because the lowest level the sine wave's valleys reach is the function generator's -1.5 V lower limit.

Amplitude and Offset for BASIC Stamp Frequency Counting

The BASIC Stamp can measure the frequencies of sine waves. ~~The PropScope's function generator output needs to be connected to an I/O pin to test this. Then a program can make the BASIC Stamp count signal cycles over some period of time to measure the frequency.~~ For the BASIC Stamp to take these measurements, the signal has to have some combination of amplitude and offset that makes it cross the BASIC Stamp's I/O pin logic input threshold. I/O pin threshold voltage was tested back in the Determining I/O Pin Threshold Voltage section on page 52, and it's typically very close to 1.4 V.

Extra Test Parts

(1) Resistor – 220 Ω (red red brown)

Test Schematic

Figure 7-10 shows a modified version of the test circuit from Figure 7-2. The only difference between this test circuit and the one from the previous activity is the extra 220 Ω resistor that connects the function generator's output to a BASIC Stamp I/O pin. So now, the function generator's output goes to both the Piezospeaker and the BASIC Stamp I/O pin.

- ✓ Add the 220 Ω resistor connecting the DAC CARD's function generator output to the I/O pin input. You can also leave it connected to the speaker's input.

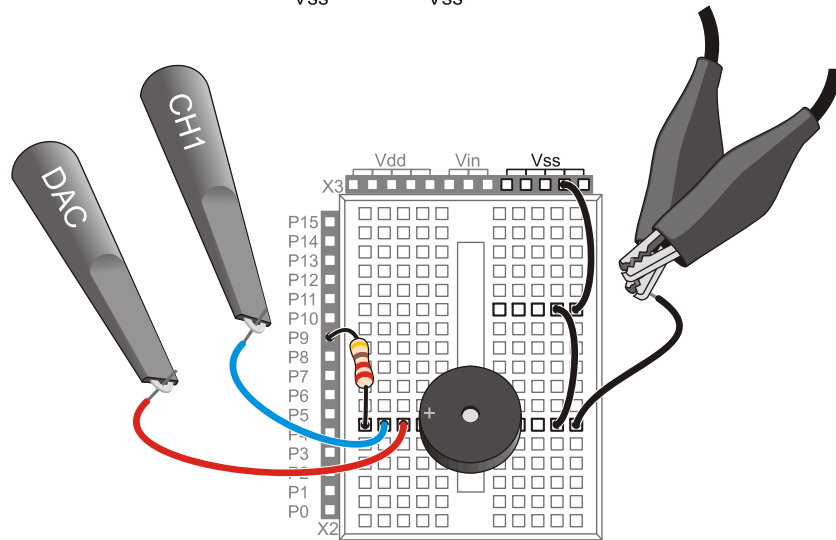
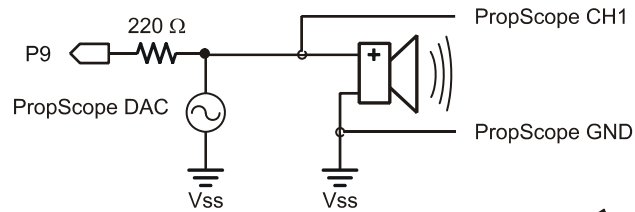

Figure 7-10
Audio
Tones Test
Circuit
Modified for
BASIC
Stamp
Monitored
Frequency

7

Test Code

Display Measured Freq.bs2 measures the number of sine wave cycles the PropScope applies to P9 during 1 second intervals and displays the result in the Debug Terminal.

- ✓ Enter and run Display Measured Freq.bs2.

```
' Display Measured Freq.bs2
' Count signal cycles applied to P9 and display in Debug Terminal

' {$STAMP BS2}                ' Target module = BASIC Stamp 2
' {$PBASIC 2.5}              ' Language = PBASIC 2.5
```

```
cycles VAR Word           ' Stores counted cycles
DO
  COUNT 9, 1000, cycles   ' Store 1 s counted in cycles var
  DEBUG HOME, "Input frequency = ", ' Display result
    DEC5 cycles, " Hz"
LOOP                       ' Repeat main loop
```

Test Procedure

The function generator should be adjusted to make the sine wave cross the BASIC Stamp's 1.4 V I/O pin input threshold.

- ✓ Set the function generator's amplitude to 1.4 V, and the offset to 2.8 V. Remember to press the Enter key to make the PropScope update its function generator output.
- ✓ Verify that the frequency the BASIC Stamp reports to the Debug Terminal agrees with the one in the PropScope Measure display, as shown in Figure 7-11.

Figure 7-11: BASIC Stamp Frequency Measurement Compared to PropScope

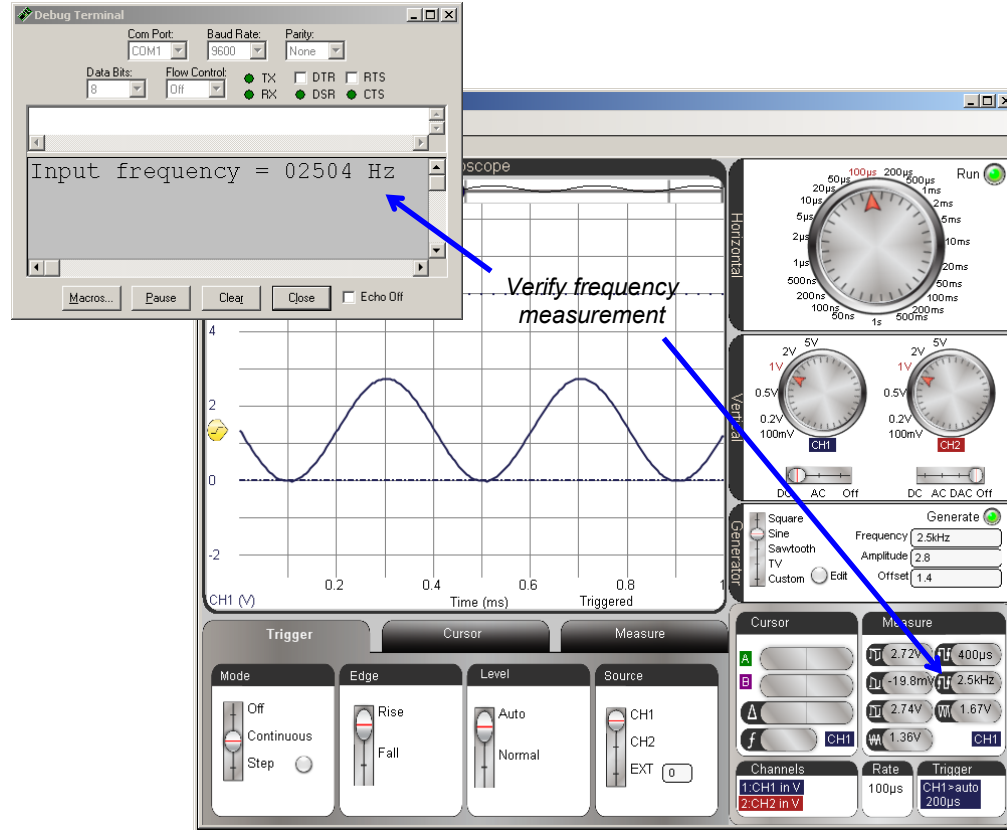

7

Your Turn: Amplitude/Offset Options to Maintain 1.4 V Crossings

Since the BASIC Stamp is just counting the number of times the signal crosses its 1.4 V threshold for a frequency measurement, the amplitude does not have to be 2.8 V. Since the offset is 1.4 V, the sine wave will still cross the I/O pin threshold with each cycle, regardless of whether the amplitude is 2.8 V, 2 V, 1 V, or even 0.5 V.

- ✓ Try a few different signal amplitudes with the 1.4 V offset, and verify that the BASIC Stamp continues to count signal cycles.
- ✓ Set the amplitude to 2 Vpp before continuing.

With a 2 Vpp sine wave, the offset can be increased to somewhere in the neighborhood of 2.4 V before the sine wave no longer passes the 1.4 V threshold.

✓ Try it. 

ACTIVITY #3: MEASURE BASIC STAMP MUSICAL NOTES

The BASIC Stamp can be programmed to transmit many sine wave frequencies, including integer versions of the musical notes shown in Figure 7-12. In this activity, you will program the BASIC Stamp to synthesize the D7# (pronounced D 7 sharp) and F7# notes. D7# is the black key below the 2489.0 Hz frequency in Figure 7-12, and F7# is the black key below 2960.0 Hz. You will then use the Oscilloscope view's cursor features to measure to examine each sine wave's amplitude, frequency, and offset.



Recommended - Music with Microcontrollers What's a Microcontroller Chapter 8 shows how to make sound effects and music with the BASIC Stamp 2 microcontroller using the same piezospeaker that's in the Understanding Signals kit. What's a Microcontroller is a free PDF download from www.parallax.com/go/WAM.

Figure 7-12: Rightmost Piano Keys and Their Frequencies
(Excerpt from What's a Microcontroller, Chapter 8)

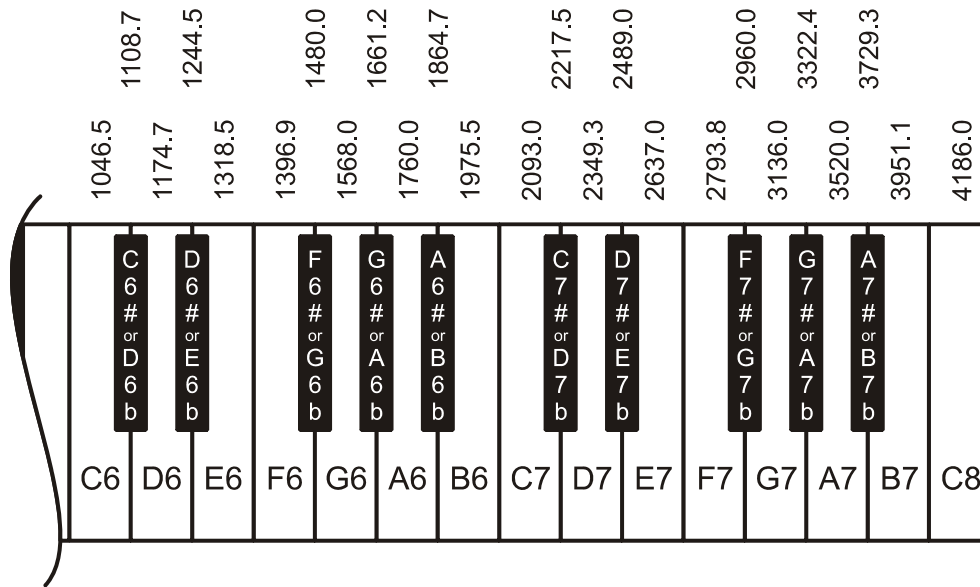

7

BASIC Stamp Tones Parts List

- (1) Piezospeaker
- (1) 1 μ F Capacitor
- (1) 220 Ω Resistor (If you have a BASIC Stamp HomeWork Board, use a wire instead.)
- (misc) Wires

BASIC Stamp Tones Circuit

Figure 7-13 and Figure 7-14 show the schematic and wiring diagram of a circuit that will allow you to alternately play a note with the piezospeaker and then view its sine wave in the Oscilloscope screen. The BASIC `FREQOUT` command instructs the BASIC Stamp to vary the duty cycle of a PWM signal at levels that follow a sine wave voltage sequence, which results in sine wave voltage variations at an RC DAC circuit's output. The 220 Ω resistor and 1 μ F capacitor function similarly to the RC DAC circuits from earlier chapters, but instead of DC voltage, the output voltage fluctuates as a sine wave.

The RC circuit does significantly reduce the piezospeaker's volume, but with the capacitor disconnected, the speaker plays a more audible tone. However, with the capacitor disconnected, the oscilloscope displays the PWM signal's rapidly switching high/low signals that "digitally synthesize" the sine wave voltage signal. Even with all that binary on/off switching the speaker tone still sounds true because the switching frequency is very high compared to what the piezospeaker can broadcast, and our ears cannot pick up frequencies that high either. So, the combination of speaker and eardrum mechanically perform filtering for our brains that is similar to what the RC circuit performs for the PropScope.

- ✓ Make sure the CH2/DAC lead is disconnected from the circuit.
- ✓ Build the circuit in Figure 7-13 and Figure 7-14.
- ✓ The capacitor's negative lead is the one that's closer to the stripe with the minus signs on the capacitor's metal canister. Make sure this lead is connected to Vss..
- ✓ Leave the 1 μ F capacitor's positive lead disconnected for now.

CAUTION:

In some circuits, connecting this type of capacitor incorrectly and then connecting power can cause it to rupture or even explode. So, always make sure to carefully connect its terminals exactly as shown in the circuit diagrams.



This capacitor has a positive (+) and a negative (-) terminal. The negative terminal is the lead that comes out of the metal canister closest to the stripe with a negative (-) sign(s).

Do not apply more voltage to an electrolytic capacitor than it is rated to handle. The voltage rating is printed on the side of the canister.

Safety goggles or safety glasses are recommended.

Figure 7-13: BASIC Stamp Controlled Piezospeaker with PropScope Probe and Capacitor for Signal Monitoring

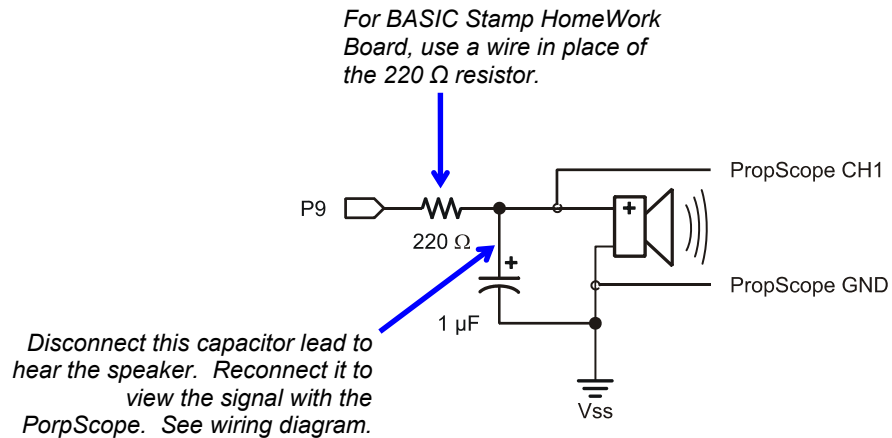

7

Figure 7-14 - Wiring Diagram for Figure 7-13

Unplug the capacitor's positive lead to hear the signal on the piezospeaker.

Reconnect the lead to view the signal with the PropScope.

This capacitor's negative terminal is the one that comes out of the canister closest to the stripe with the negative (-) sign(s). **Make sure to plug the negative (-) terminal in here.**

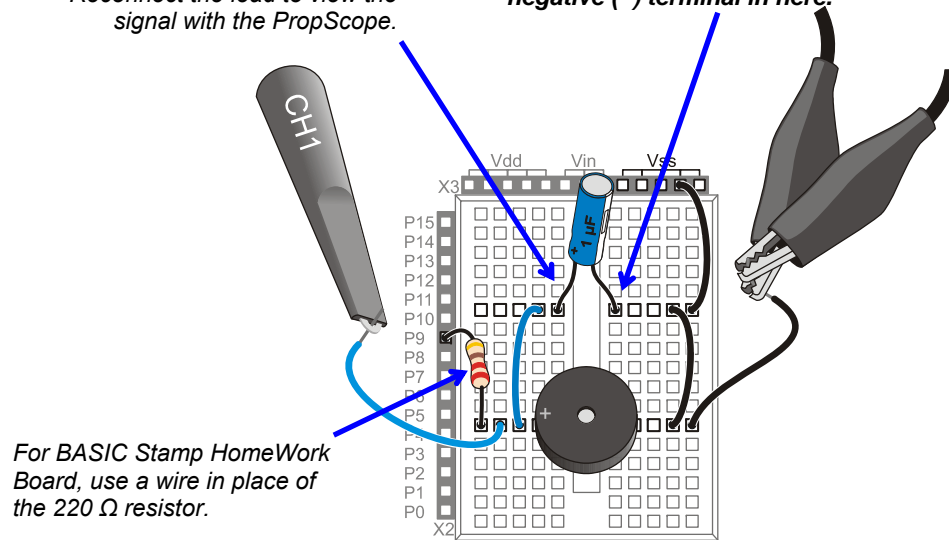

Listen to the Notes First

Two Notes.bs2 plays the note D7# (2489 Hz), followed by F7# (2960 Hz). As mentioned earlier, it uses the FREQOUT command to digitally synthesize sine waves for these notes. The command FREQOUT 9, 2000, 2489 makes I/O pin P9 synthesize a 2489 Hz sine wave for 2 seconds. Then, FREQOUT 9, 2000, 2960, synthesizes a 2960 Hz sine wave for 2 seconds.

- ✓ Enter Two Notes.bs2 into the BASIC Stamp Editor and run it.
- ✓ Disconnect the 1 µF capacitor's positive lead from the circuit.
- ✓ Listen carefully to the two individual notes.
- ✓ Press and release the RESET button on your board a couple of times to re-run the program.

```
' Two Notes.bs2
' Play D7#, followed by F7#.

' {$STAMP BS2}
' {$PBASIC 2.5}

PAUSE 1000
' Wait 1 second before 1st message

DEBUG "2489 Hz", CR
FREQOUT 9, 2000, 2489
' Play/display D7#

DEBUG "0 Hz", CR
PAUSE 500
' 1/2 s rest

DEBUG "2960 Hz", CR
FREQOUT 9, 2000, 2960
' Play/display F7#

DEBUG "0 Hz", CR
PAUSE 500
' 1/2 s rest

DEBUG "Done!", CR
' Display done

END
' Enter low power mode
```

Play an Individual Note for Oscilloscope Viewing

One Note at a Time.bs2 makes the BASIC Stamp play the D# note indefinitely. You can instead play the F# note by commenting FREQOUT 9, 60000, 2489 by placing an apostrophe ' to the left of it. After that, remove the apostrophe to the left of FREQOUT 9, 60000, 2960 and load the modified program into the BASIC Stamp.

- ✓ Enter and run One Note at a Time.bs2 as-is.
- ✓ After you are satisfied that it plays the note indefinitely, plug the capacitor's positive terminal back in using Figure 7-14 as a guide.
- ✓ The note should be much quieter, maybe even barely audible, but the sine wave will look much better on the Oscilloscope screen.

```
' One Note at a Time.bs2
' Select whether to play D7#, or F7# indefinitely.

' {$STAMP BS2}           ' Target module = BASIC Stamp 2
' {$PBASIC 2.5}         ' Language = PBASIC 2.5

DEBUG "Program running..."      ' Debug Terminal message

DO                                ' Main Loop

  FREQOUT 9, 60000, 2489          ' Play 2489 Hz for 1 minute
  ' FREQOUT 9, 60000, 2960        ' Commented, does not play

LOOP                              ' Repeat main loop w/o delay
```

7

Examine the DC Offset, Amplitude and Frequency

Figure 7-15 shows the BASIC Stamp synthesized D7# note in the Oscilloscope view.

- ✓ Set the Oscilloscope dials to: Horizontal = 100 μ s/div, Vertical CH1 = 1 V/div.
- ✓ Vertical Coupling switches: CH1 = DC, CH2 = Off.
- ✓ Trigger Tab switches: Mode = Continuous, Edge = Rise, Level = Auto, Source = CH1.
- ✓ Trigger Time Control: align with first time division line. (See in Figure 7-15).
- ✓ Optional: Click, hold and drag the CH1 ground line downward until it is just above the time division scale values.

Figure 7-15: FREQOUT 9, 60000, 2489 in Oscilloscope

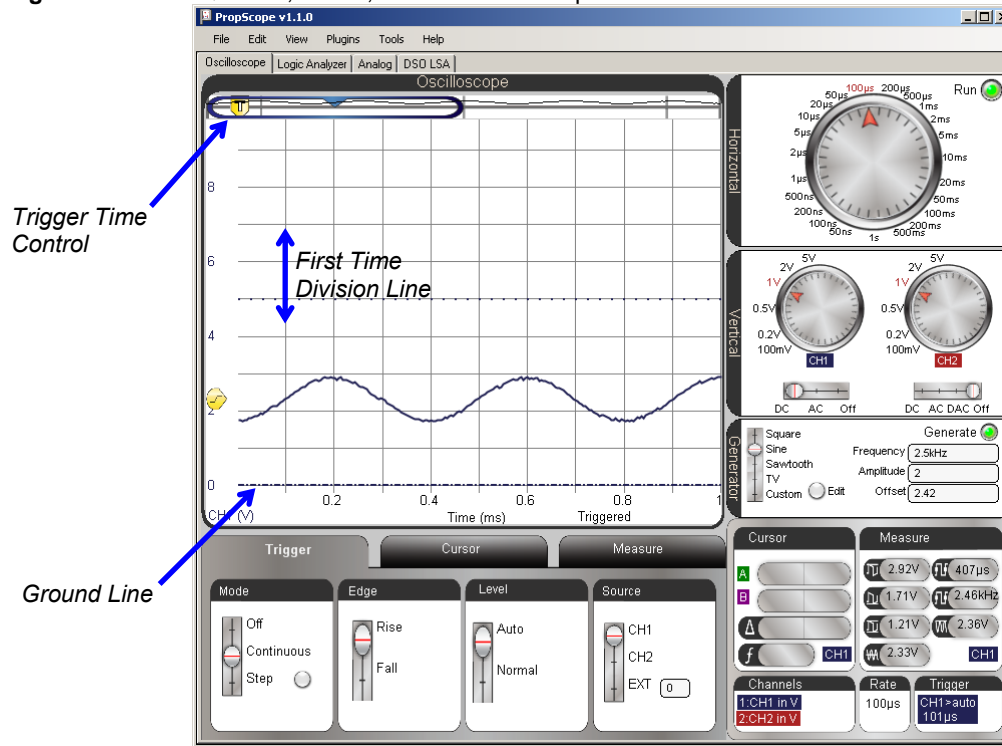

Note that the sine wave in Figure 7-15 has a DC offset like the ones that we added to the PropScope DAC sine waves in Activity #2. You can use the Measure display to get an automated DC offset measurement. This same measurement is also displayed in the Oscilloscope view's Measure tab. Both are shown in Figure 7-16.



- ✓ Click the Measure tab and check the CH1 Average Voltage. It should resemble the example in.
- ✓ Repeat using the Measure display.

Figure 7-16: Sine Wave DC Offset

...is measured as the signal's average voltage component

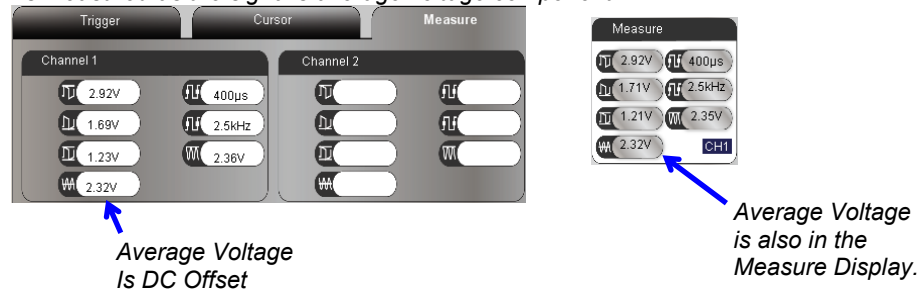

You can also use the PropScope software's horizontal and vertical cursors to measure amplitude and frequency. Figure 7-17 shows an example. The amplitude is the peak-to-peak-voltage, so place one horizontal cursor at the tops of the sine wave's peaks, and the other at the bottoms of its valleys. The average voltage is the ~~half-way~~ point between the sine wave's peaks and valleys. Frequency can be determined from period, and the vertical cursors can be used to measure the amount of time it takes the signal to repeat itself. One way to do that is to align the vertical cursors with the centers of the sine wave's peaks.

7

- ✓ In the Cursor tab, click the Vertical and Horizontal buttons to make the vertical and horizontal cursors appear.
- ✓ Align the green horizontal cursor A with the tops of the sine wave's peaks.
- ✓ Align the purple horizontal cursor B with the bottoms of the sine wave's valleys.
- ✓ Align the green vertical cursor A with the center of the top of the sine wave's first peak.
- ✓ Align the purple vertical cursor B with the center of the next second sine wave peak.
- ✓ Check the measurements in the Cursor display by the Oscilloscope screen's lower-right corner.

Figure 7-17: Cursor Measurements

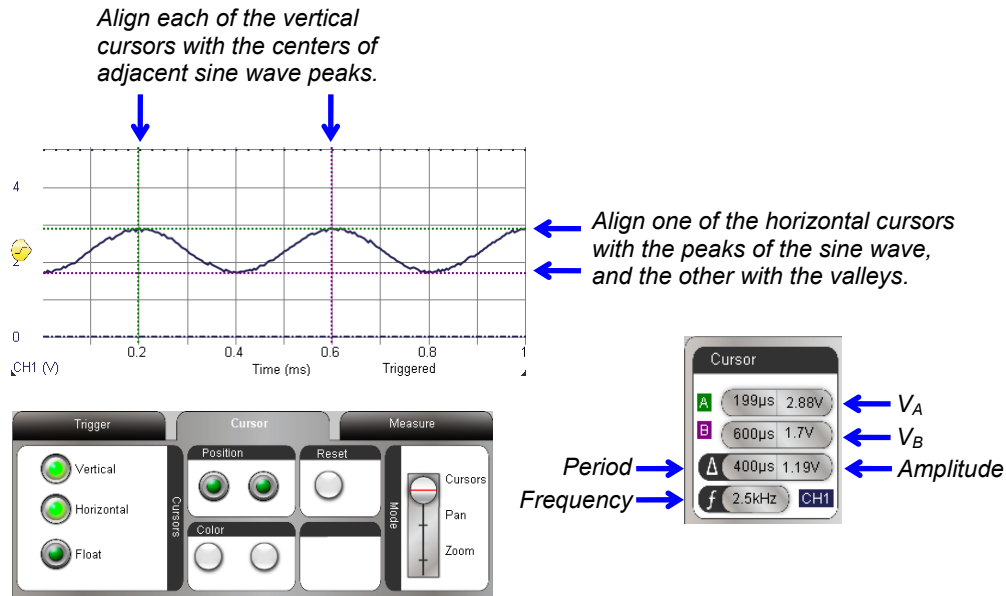

In Figure 7-16, the Measure tab and display report amplitudes of 1.23 and 1.21 V. Since the cursor measurement from Figure 7-17 is 1.19 V it verifies that these measurements are in the right ballpark. Likewise with frequency measurements, both figures report 2.5 kHz. With the BASIC Stamp programmed to transmit 2489 Hz, these measurements indicate that the BASIC Stamp’s program and circuit are all working as intended. (This is the type of intermediate testing step you might see in a design that has an audio tones subsystem.)

The cursors can also provide enough information to verify the average voltage measurement the Measure tab and display reported. For a sine wave, the half-way point between the sine wave’s voltages at its peaks and valleys is the average of the two voltages. To calculate this average, just add the two cursor measurements, which are V_A and V_B in Figure 7-17, and divide by two:

$$\text{DC Offset} = \text{Average Voltage} = (V_A + V_B) \div 2$$

For the cursor measurements in Figure 7-17, that’s:

$$\begin{aligned} \text{DC Offset} &= (2.88 \text{ V} + 1.7 \text{ V}) \div 2 \\ &= 2.29 \text{ V} \end{aligned}$$

The calculated DC offset value of 2.29 V from the cursor measurements is close enough to confirm the measured value of 2.32 V back in Figure 7-16.

Your Turn: Examine the F7# Sine Wave

Try taking a closer look at the F7# sine wave. Start by modifying One Note at a Time.bs2, and then examine the new signal. Because of the way the signal interacts with the resistor and capacitor, it may be a slightly lower amplitude. Since it's a higher frequency signal, you can also expect the period to be slightly shorter.

- ✓ In the BASIC Stamp Editor modify One Note at a Time.bs2 by placing an apostrophe to the left of `FREQOUT 9, 60000, 2489`. Then, delete the apostrophe to the left of `FREQOUT 9, 60000, 2960`.
- ✓ Load the modified program into the BASIC Stamp.
- ✓ Repeat this activity's offset, amplitude and frequency measurements.

7

ACTIVITY #4: SUMMED SINE WAVES

A piano player presses several keys at a time to make sounds called chords. The notes seem to blend, and it's an example of a group of sine waves, one for each note, added together. Examples of pairs of sine waves added together can be found in touchtone phones. Each key press makes a unique tone that transmits that key's value. Since each touchtone is two tones added together, it's called dual tone frequency modulation (DTMF).

In addition to individual frequencies, the BASIC Stamp can be programmed to transmit two sine wave frequencies at once. This makes it possible to play part of a chord. In this activity, you will compare the D7# and F7# note frequencies from the previous activity against the two notes played together. As with the previous activity, you will listen to the results on the piezospeaker first, and then examine the signals with the PropScope's Oscilloscope view.



DTMF Tones The BASIC Stamp can also play DTMF tones with the `DTMFOUT` command. Although they can be viewed with the PropScope, the tones' frequencies are typically too low to be audible through piezospeaker in the understanding signals kit.

Listen to Each Note; then Play them Together

This example program starts off the same as the Two Notes.bs2 example from the previous activity – it plays the D7# and F7# notes individually. After that, it plays them simultaneously. FREQOUT 9, 2000, 2489, 2960 uses the FREQOUT command's optional Freq2 argument together with the Freq1 argument to play the both sine waves together.

- ✓ Disconnect the capacitor's positive lead from the piezospeaker circuit so that you can hear the notes the piezospeaker plays.
- ✓ Enter Two Notes Together.bs2 into the BASIC Stamp Editor and load it into the BASIC Stamp.
- ✓ Listen carefully again to the two individual notes followed by the notes played together.
- ✓ Listen again and try to hear the differences in the three tones by pressing and releasing the RESET button on your board to re-run the program.

```
' Two Notes Together.bs2
' Play D7#, followed by F7#, followed by D7# + F7# together.

' {$STAMP BS2}
' {$PBASIC 2.5}

PAUSE 1000
' Wait 1 s before first message

DEBUG "2489 Hz", CR
FREQOUT 9, 2000, 2489
' Play/display D7#

DEBUG "0 Hz", CR
PAUSE 500
' 1/2 s rest

DEBUG "2960 Hz", CR
FREQOUT 9, 2000, 2960
' Play/display F7#

DEBUG "0 Hz", CR
PAUSE 500
' 1/2 s rest

DEBUG "2489 Hz + 2960 Hz", CR
FREQOUT 9, 2000, 2489, 2960
' Play/display D7# + F7#

DEBUG "Done!", CR
' Display done

END
' Enter low power mode
```

Play an Individual Note for Oscilloscope Viewing

One or Two Notes at a Time.bs2 makes it possible to play either the D7# note, or the F7# note, or both at the same time. As with the previous activity, this program transmits whichever note you leave un-commented indefinitely.

- ✓ Enter and run One or Two Notes at a Time.bs2 as-is.
- ✓ After verifying that the note is clearly audible, reconnect the capacitor's positive lead to the circuit.

As before, the note's volume may drop considerably, but the signal displayed by the PropScope will be much cleaner.

```
' One or Two Notes at a Time.bs2
' Select whether to play D7#, or F7#, or D7# + F7# together.

' {$STAMP BS2}                                ' Target module = BASIC Stamp 2
' {$PBASIC 2.5}                                ' Language = PBASIC 2.5

DEBUG "Program running..."                   ' Debug Terminal message

DO                                              ' Main Loop

  FREQOUT 9, 60000, 2489                        ' Play 2489 Hz for 1 minute
  ' FREQOUT 9, 60000, 2960                      ' Commented, does not play
  ' FREQOUT 9, 60000, 2489, 2960              ' Commented, does not play

LOOP                                           ' Repeat main loop
```

7

AC Couple the Signal

Each PropScope Vertical coupling switch has a setting that removes DC offset from a signal –it's called AC coupling. When you use this setting, it causes the sine wave voltages to swing above/below the ground line (0 V level), removing any offset you might see if you viewed it with DC coupling. In some measurements, DC offset doesn't matter, but other properties of the sine wave do. In those situations, AC coupling can simplify the measurements, especially if the two signals have different DC offsets.

Another important setting is the Trigger tab Level switch's Normal setting. This allows you to pick your own voltage level for triggering the display. This setting will be useful for aligning the trigger event to a high peak in the signal with two sine waves added together. Figure 7-18 shows the AC coupled D7# note from the BASIC Stamp with

Normal (instead of Auto) trigger voltage level. It also shows the other settings we'll use to compare the individual frequencies against the frequencies added together.

- ✓ Click the Cursor tab's Horizontal and Vertical buttons to toggle them off.
- ✓ Oscilloscope dials: Horizontal = 500 $\mu\text{s}/\text{div}$, Vertical CH1 = 0.5 V/div
- ✓ Vertical Coupling Switches: CH1 = AC, CH2 = Off
- ✓ Click and drag the CH1 trace up/down and make the CH1 -1 V division line up with the bottom of the oscilloscope display.
- ✓ Trigger tab switches: Mode = Continuous, Edge = Rise, Level = Normal, Source = CH1.
- ✓ If needed, adjust the Trigger Voltage Control to make the horizontal trigger crosshair line up with the CH1 ground (0 V) division line.
- ✓ Trigger Time Control  Adjust to make one of the sine wave's peaks line up with the middle time division line. It doesn't matter where the vertical trigger time crosshair is, just make sure a peak in the sine wave is lined up with the middle time division line. See example in Figure 7-18.

Figure 7-18: FREQOUT 9, 60000, 2489 Signal AC Coupled in the Oscilloscope



7

Compare a Dual Tone Signal to its Component Sine Waves

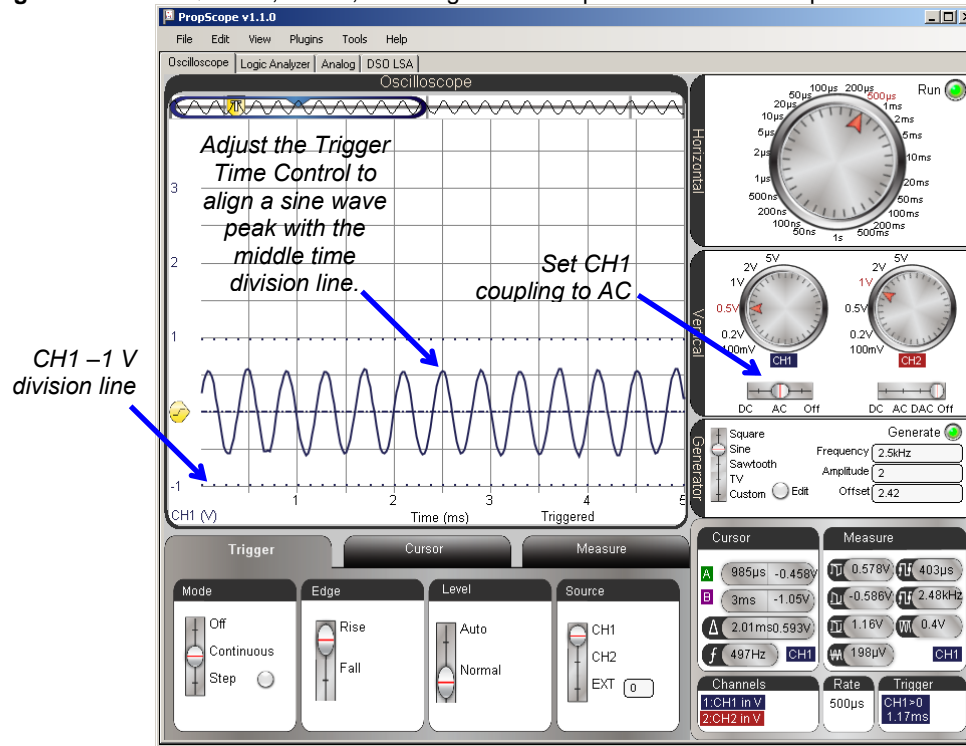
Two Notes Together.bs2 played each individual note, and then both notes together. What do you think the signal will look like when both notes are played together? Let's use the PropScope to find out. First, let's take pictures of the individual D7# and F7# notes and save them for comparison:

- ✓ Make a copy of the oscilloscope screen for later reference by clicking the Edit Menu and selecting Copy Image.
- ✓ Paste it into Paint (Start → All Programs → Accessories → Paint.)
- ✓ Save the file as 2489 Hz.bmp.

The next step is to modify One or Two Notes at a Time.bs2 so that it plays the F7# (2960 Hz), and then take a screen capture of that waveform.

- ✓ In the BASIC Stamp Editor, modify One or Two Notes at a Time.bs2 by placing an apostrophe to the left of `FREQOUT 9, 60000, 2489`.
- ✓ Delete the apostrophe to the left of `FREQOUT 9, 60000, 2960`.
- ✓ Load the modified program into the BASIC Stamp.
- ✓ Use the Trigger Time Control to line up one of the peaks of one sine wave with the middle time division line in the screen again.
- ✓ Take a screen capture and save it as 2960 Hz.bmp

Now that the individual notes have been examined and their screen captures stored, play both notes together. Then, examine the resulting signal and take a screen capture of it too.

- ✓ In the BASIC Stamp Editor modify One or Two Notes at a Time.bs2 by placing an apostrophe to the left of `FREQOUT 9, 60000, 2960`.
- ✓ Delete the apostrophe to the left of `FREQOUT 9, 60000, 2489, 2960`.
- ✓ Load the modified program into the BASIC Stamp.
- ✓ Slide the Trigger Voltage Control to make the horizontal crosshair line up near the top of the highest peak in the waveform. (This will keep it from scrolling in the display.)
- ✓ Use the Trigger Time Control to line up the highest peak with the middle time division line. For an example, take a look at the bottom waveform in Figure 7-19.
- ✓ Take a screen capture and save it as 2489 and 2960 Hz.bmp

Figure 7-19 conveys the basic idea of how adding two sine waves together works. (Actually, both sine waves are divided by 2 first and then added for the result at the bottom of the figure.) For example, a peak on the top sine wave added to a valley in the middle sine wave results in zero on the bottom waveform. The two values cancel each other out. Another example, two peaks in the component waveforms get added together to form the highest peak in the bottom waveform. Again, the BASIC Stamp adds $\frac{1}{2}$ of the top waveform amplitude to $\frac{1}{2}$ of the middle waveform's amplitude. That's why the bottom waveform's peak is not twice as high.

- ✓ Carefully examine Figure 7-19, and make sure you can see how $\frac{1}{2}$ of each component sine wave is added together to make the resulting waveform that contains both musical notes.
- ✓ Try opening your screen captures, combining them together in a single document, and lining them to repeat the comparisons in Figure 7-19.

Figure 7-19: Two Sine Waves Added Together

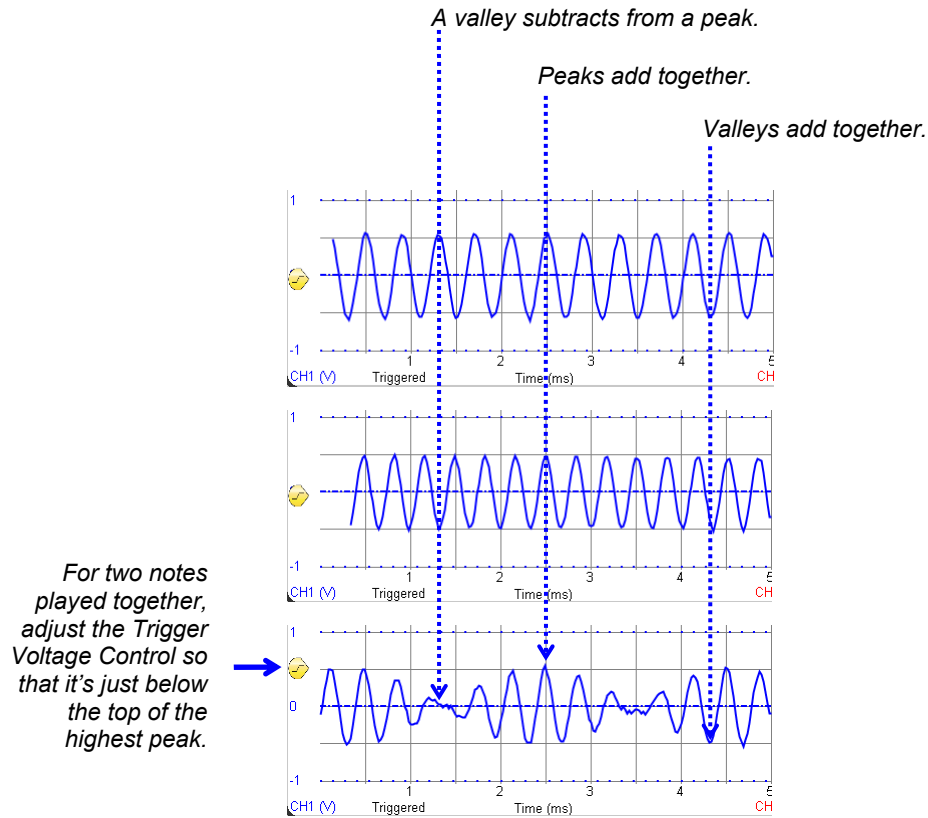

7

Your Turn: 100 and 200 Hz

Figure 7-20 shows an example of 100 and 200 Hz added together. These tones will not be audible with the piezospeaker, but you can still measure them with the PropScope.

- ✓ Modify One or Two Notes at a Time.bs2 for use with these two frequencies.
- ✓ Plot and screen capture the components.
- ✓ Plot and screen capture the sum.
- ✓ Examine the effect of the peaks and troughs adding together.

Figure 7-20: Waveform with 100 and 200 Hz Components

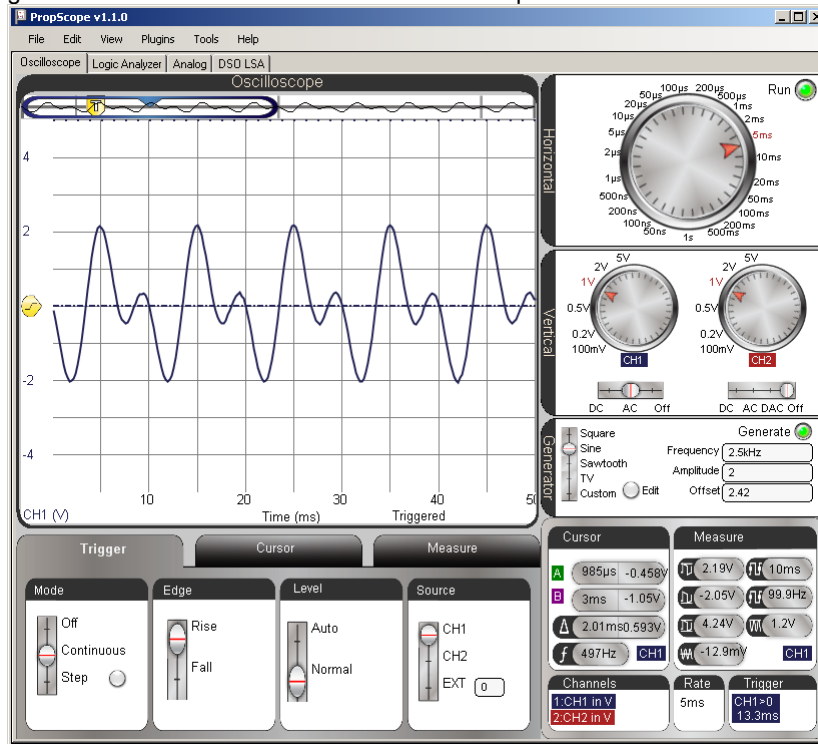

ACTIVITY #5: SINE COMPONENTS WITH A SPECTRUM ANALYZER

What are the frequencies of the sine wave components in the Figure 7-21 waveform? Here's a hint, they are not D7# and F7#. So, what are they? Could you use the cursors to figure it out? Maybe, but it might turn out to be difficult and time consuming. The answer to the question is that this is FREQOUT 9, 60000, 2349, 3136, which is the BASIC Stamp playing the D7 and G7 notes from Figure 7-12 on page 285.

Figure 7-21: Mystery Waveform

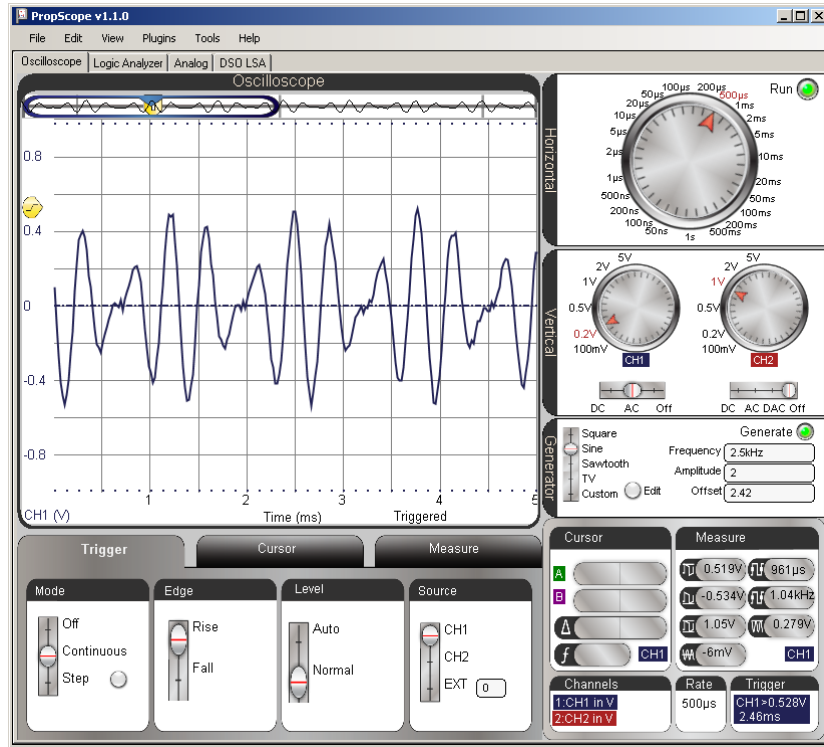

7

A spectrum analyzer is a device that measures and displays the frequencies and relative amplitudes of a signal's sine wave components. The PropScope's analog tab has a spectrum analyzer built-in. Let's try it.

- ✓ Enter D and G Notes.bs2 into the BASIC Stamp Editor and load the program into the BASIC Stamp.

```
' D and G Notes.bs2
' Play D7 and G7 notes together.

' {$STAMP BS2}
' {$PBASIC 2.5}

DEBUG "Program running..."

DO
```

```
FREQOUT 9, 60000, 2349, 3136      ' Play 2389 + 3136 Hz for 1 min.  
LOOP                               ' Repeat main loop
```

- ✓ View the waveform in your PropScope's Oscilloscope view using Figure 7-21 as a guide for settings.
- ✓ Click the Analog tab. It's in the same group with Logic Analyzer and Oscilloscope.

Figure 7-22 shows the Analog view, which includes three major tools, the now familiar oscilloscope, the Spectrum Analyzer, and XY Plot. The Spectrum Analyzer screen makes short work of determining the frequency components that might have looked somewhat confusing in the Oscilloscope screen.

Figure 7-22: Analog View with frequency components of the signal in Figure 7-21

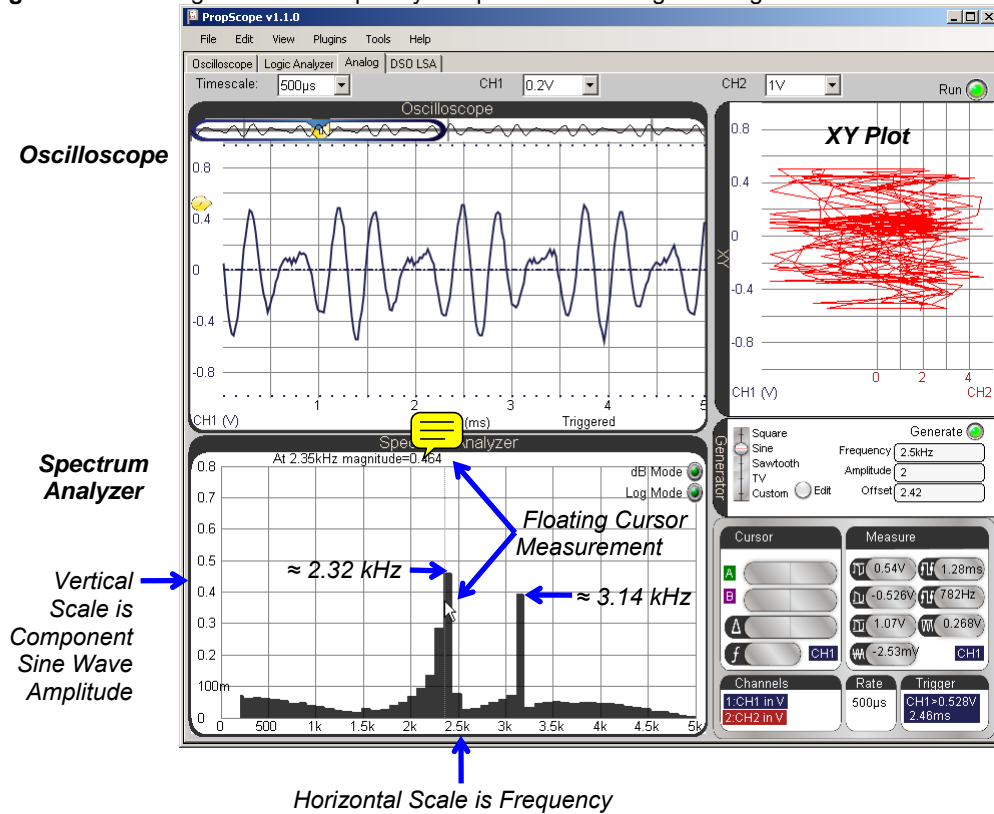

7

In contrast to an oscilloscope, which plots voltage against time, a spectrum analyzer plots sine wave component amplitudes against frequency. The heights of the two vertical bars in the Spectrum Analyzer screen indicate the two sine wave component amplitudes, and their left-right positions place them over their frequencies. For example, the left bar in the spectrum analyzer has a height that lines up with about 0.46 V on the vertical scale, and is over the 2.35 kHz frequency on the horizontal scale. The bar to its right has a height that lines up with about 0.4 V on the vertical scale, and is over the 3.14 kHz frequency on the horizontal scale. This confirms what we know about D and G Notes.bs2. It transmits a signal that is the sum of two sine waves with frequencies of 2349 Hz and 3136 Hz. With the ability to indicate a waveform's sine wave component amplitudes and frequencies, the spectrum analyzer is quite a handy tool.

Figure 7-22 also shows a floating cursor measurement. As you point your mouse at positions on the screen, the floating cursor measurement is displayed in the top-left of the Spectrum Analyzer screen. In the figure, the floating cursor's vertical crosshair is lined up with the left bar, and the measurement shows: At 2.35 kHz magnitude=0.434.

- ✓ Use the floating cursor to check the amplitude and frequency of each of the bars in your spectrum analyzer.

 **Spectrum Analyzer Units**

By default, the spectrum analyzer displays amplitude in terms of Vpp and frequency in terms of Hz. Both scales are linear. If you click the Log Mode button, the frequency units will increase logarithmically instead of linearly. If you click the dB Mode button, the amplitude will display as decibels instead of peak-to-peak volts.



Sine Waves in a Square Wave?

It turns out that some variety of sine waves can be added together to create just about any signal you can display with your Oscilloscope. That also means that just about any signal you display in the Oscilloscope is composed of one or more sine waves, and the Spectrum Analyzer is your tool determining a signal's component sine waves. The PropScope's spectrum analyzer performs a Fast Fourier Transform (FFT) on the oscilloscope signal to determine its sine wave components.

 **A Fourier Series** is a sum of sine waves that creates an arbitrary waveform. It is named after Joseph Fourier, the French Mathematician and Physicist who developed the technique of describing certain mathematical functions as sums of sine wave equations.

A Fourier Transform is the inverse of a Fourier Series. Given a mathematical function, it resolves it into its Fourier Series of sine wave components.

A Fast Fourier Transform is a widely used technique for determining a signal's sine wave components using fewer steps and less computing time.

Microcontrollers and other systems that exchange information with high/low signals have the potential to cause radio frequency (RF) interference. A radio transmitter applies a sine wave of a certain frequency to  antenna to broadcast. A radio receiver tuned for the transmitter's broadcast detects them as sine wave voltage variations it gets from its own antenna. It turns out that binary signals like square waves contain many sine waves with many different frequencies. So, when a microcontroller applies a square wave to a wire (antenna), it has the potential to ~~be like~~  a radio transmitter that generates RF interference at many different frequencies. Many electronic devices have to be tested to

ensure that they do not broadcast at certain frequencies with signals that are strong enough to be received as interference by nearby radio receivers.

To test this, the PropScope DAC CARD's function generator can generate the square wave, and then the Spectrum Analyzer can display the frequency components.

- ✓ Set up your PropScope's hardware to transmit signals from the DAC CARD's function generator to the CH1 probe. (Instructions and circuit for this were first introduced in the Set DC Voltages with the PropScope's DAC CARD section starting on page 43.)
- ✓ Configure the Generator panel to make the DAC CARD's function generator output transmit a 1 kHz, 1.5 Vpp, 0 V offset square wave. (You can use the Generator panel settings in Figure 7-23 as a guide.)

Figure 7-23: 1 kHz, 1.5 Vpp, 0 V_{DC} Offset Square Wave

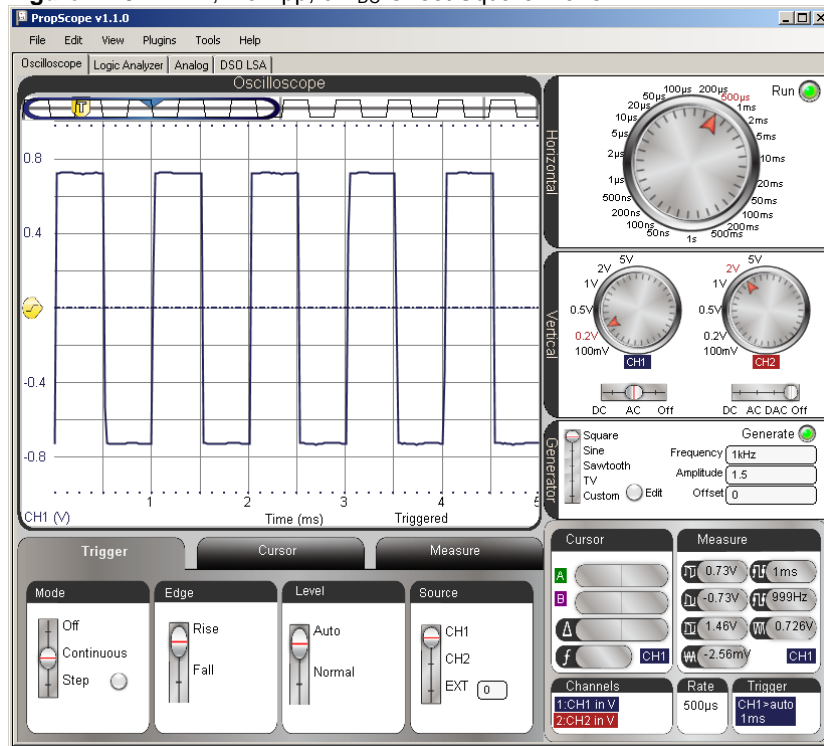

7

Next, even though the Analog view has variations on most of the controls you've been using in Oscilloscope view, it's better to set up the measurement in the Oscilloscope view and then switch over. Then, you can make minor adjustments in the Analog view to get the information you need.

For the clearest spectrum analysis, it's best to have four to eight cycles of the signal displayed in the Oscilloscope, and the voltage scale should make the waveform fill at least half of the total voltage amplitude the Oscilloscope can display. Along with the function generator settings, Figure 7-23 also shows an example of our square wave measured with CH1. It displays almost five full cycles and fills $\frac{3}{4}$ of the total ± 1 V amplitude that the Oscilloscope can display with the CH1 vertical dial set to 0.2 V/div. Remember, these limits are indicated by the dotted lines, which are visible near the top and bottom of the oscilloscope screen in Figure 7-23.



- ✓ Set the dials to: Horizontal = 500 μ s/div, Vertical CH1 = 0.2 V/div.
- ✓ Set the Vertical coupling switches to: CH1 = AC, CH2 = Off.
- ✓ Drag the display up/down to position the ground line in the middle of the oscilloscope display.
- ✓ Set the Trigger tab's switches to: Mode = Continuous, Edge = Rise, Level = Auto, and Source = CH1.

Figure 7-24 shows an example of how the Analog View should look when after you configure your Oscilloscope display and then click the Analog view tab. The Spectrum Analyzer shows several of the sine wave components that compose the square wave. These components are called harmonics. When a square wave is transmitted from one circuit to another along a wire, the wire can act like a small antenna, and broadcasts the harmonics. So, the 1 kHz square wave might be generating small amounts of radio interference at the 1 kHz, 3 kHz, 5 kHz, 7 kHz, 9 kHz and on up the frequency spectrum at odd multiples of the square wave's frequency. Note that as the frequency of the harmonic increases, its amplitude decreases.



- ✓ Click the Analog tab.

The Spectrum analyzer will probably display a horizontal frequency scale of 0 to 5 kHz. So only the first three sine wave harmonics will be visible. You can adjust the Spectrum Analyzer's frequency scale with your mouse. Just point at the Spectrum Analyzer screen, and then click, hold and drag either right or left. Dragging left increases the frequency scale; dragging right decreases it.

- ✓ To increase the frequency scale for viewing more harmonics, point at the Spectrum Analyzer screen with your mouse, then click, hold, and drag left.
- ✓ Adjust the your Spectrum Analyzer plot so that it resembles the lower portion of Figure 7-24 with a frequency scale of 0 to 10 kHz.

Figure 7-24: Sine Wave Components in a Square Wave

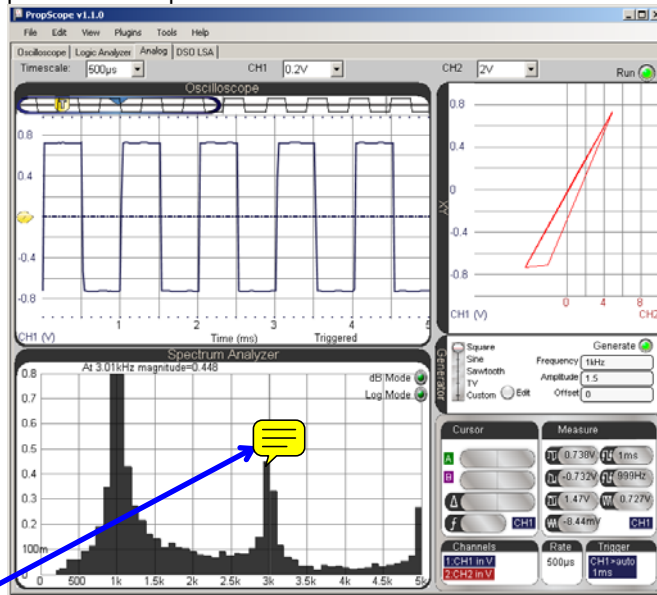

7

Point at the Spectrum Analyzer screen with your mouse. Then, click, hold, and drag left until the Spectrum Analyzer's frequency scale displays from 0 to 10k.

The result should look like this.

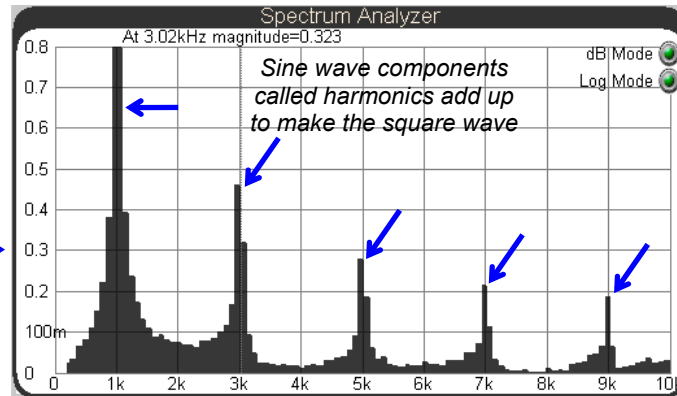



A **square wave** is made up of an infinite number of sine wave components, starting with a sine wave at the square wave's frequency called the fundamental. The next sine wave is smaller amplitude, and at three times the fundamental. It's called the third harmonic. The next higher frequency sine wave is called the fifth harmonic, and not surprisingly, it is five times the square wave's frequency, and has an even smaller amplitude. This pattern continues for every odd multiple of the square wave's frequency.

Your Turn: Harmonics in a Sawtooth Wave

It takes a different set of sine waves to construct a sawtooth wave.

- ✓ Change the Generator panel's Function switch to Sawtooth.
- ✓ What sine wave component frequencies are present in a sawtooth wave that are not present in a square wave?



ACTIVITY #6: COMPARE TWO SINE WAVES

Circuits like filters and amplifiers that process sine waves can be analyzed by comparing a sine wave that enters the circuit's input against the one the circuit transmits at its output. ~~The two sine wave attributes~~ that tend to change at the circuit's output are amplitude and phase. Amplifiers might create a larger amplitude sine wave, and filters might make the sine wave a little or a lot smaller, depending on the frequency of the sine wave and certain properties of the filter. Filters also tend to introduce a delay in the output signal. There's no change in frequency, but the output sine wave's points all occur slightly later than they do on the input wave. This delay is called phase shift.

The RC circuit we have been using for the BASIC Stamp DAC voltages is a type of filter called a low-pass filter. Given an input sine wave, it will reduce the amplitude and shift the phase of the output signal. The amplitude change and phase shift depend on the combination of RC values and the frequency of the input signal. In this activity, you will measure amplitude and phase shift changes that an RC circuit introduces into a sine wave. Later, in Chapter 8, Activity #5, you will also use amplitude and phase comparisons to quantify properties of the filter.

Sine Wave Phase Angle and Phase Shift

The degree increments you are probably familiar with for measuring angles can also be used to measure how much of a sine wave cycle has elapsed. When applied to a sine wave, these degree measurements are called phase angles, and Figure 7-25 shows some examples. A full sine wave cycle is considered 360°, and any fraction of a full cycle can

be measured as a certain number of degrees. This gives us a way of describing how far into the cycle a certain time is, regardless of the frequency.

For example, 90° is ¼ of the way into the cycle. If the sine wave's frequency is 1 kHz, that happens at 0.25 ms into the sine wave. If the frequency is 2 kHz, that happens at 0.125 ms into the cycle. Regardless of the frequency, if the time is ¼ of the way into the sine wave cycle, the sine wave is at a phase of 90°



Figure 7-25: Sine (θ) Vs. θ and Time for 1 and 2 kHz Signals

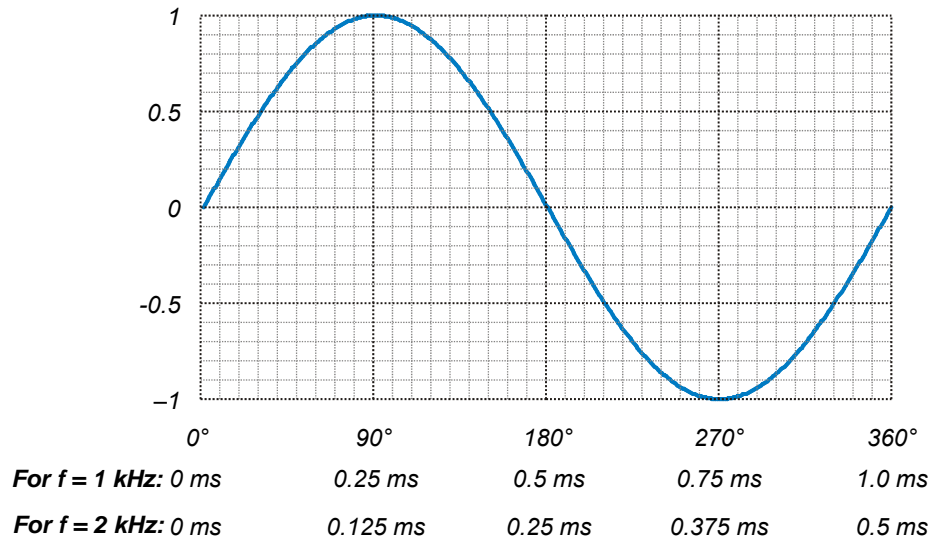

To learn more about phase angle and other sine wave math topics, see Appendix B: Basic Sine Wave Math.

You can convert a phase for any frequency to a degree measurement by keeping in mind that the ratio of θ to 360° is the same as the ratio of the time (t) to the cycle's period (T). From that, a phase angle equation is simple. Just multiply both sides of the equation by 360° to solve for θ.

$$\frac{t}{T} = \frac{\theta}{360^\circ} \rightarrow \theta = \frac{t}{T} \times 360^\circ$$

The equation $\theta = (t \div T) \times 360$ is saying that the phase angle θ is equal to the time t of a point on the sine wave, divided by its period T , and multiplied by 360° . For example, let's say we have a 2 kHz sine wave. That's a frequency, but we need to know its period T . Remember the period is the reciprocal of frequency, so you can use $T = 1 \div f$ to calculate the period.

$$T = \frac{1}{f} \rightarrow T = \frac{1}{2000 \text{ Hz}} = 0.0005 \text{ s} = 0.5 \text{ ms}$$

Let's say we want to know the phase angle of a point that's $t = 0.375$ ms into a cycle of the 2 kHz sine wave. Since we know its period is 0.5 ms, we have all the values we need to calculate the phase angle.

$$\theta = \frac{t}{T} \times 360^\circ = \frac{0.375 \text{ ms}}{0.5 \text{ ms}} \times 360^\circ = 270^\circ$$

TIP: Since $f = 1/T$, you could replace t/T with $t \times f$ for this equation:

$$\theta = t \times f \times 360^\circ$$

This can save you the frequency to period conversion calculation. For example, If $t = 0.375$ ms and $f = 2$ kHz:

$$\theta = 0.000375 \text{ s} \times 2000 \text{ Hz} \times 360^\circ = 270^\circ$$

- ✓ Take a look at Figure 7-25. Does the 0.375 ms match with 270° for a 2 kHz signal?
- ✓ Repeat this exercise for 0.125 ms in a 2 kHz signal and 0.25 ms in a 1 kHz signal. Make sure to check your results against Figure 7-25.
- ✓ Try 0.125 ms for a 1 kHz signal. The correct answer is 45° .

Some circuits introduce delays between input and output signals. For sine waves, this delay can be expressed as a phase angle measurement. For example, all the points in the 1 kHz signal labeled v_2 in Figure 7-26 occur 0.125 ms later than the corresponding points in the v_1 signal. Using phase angle math, we can calculate that v_2 lags behind v_1 by 45° , or that v_1 leads v_2 by 45° . In oscilloscope terminology, the expressions: “ v_1 leads v_2 ” and “ v_2 lags v_1 ” are common. The angle Φ is negative when measured from a reference

sine wave to another that lags, or positive when measured to another sine wave that leads. So, the Φ from v_1 to v_2 is -45° , and from v_2 to v_1 is $+45^\circ$.

Figure 7-26: Identical Sine Waves with Different Phases

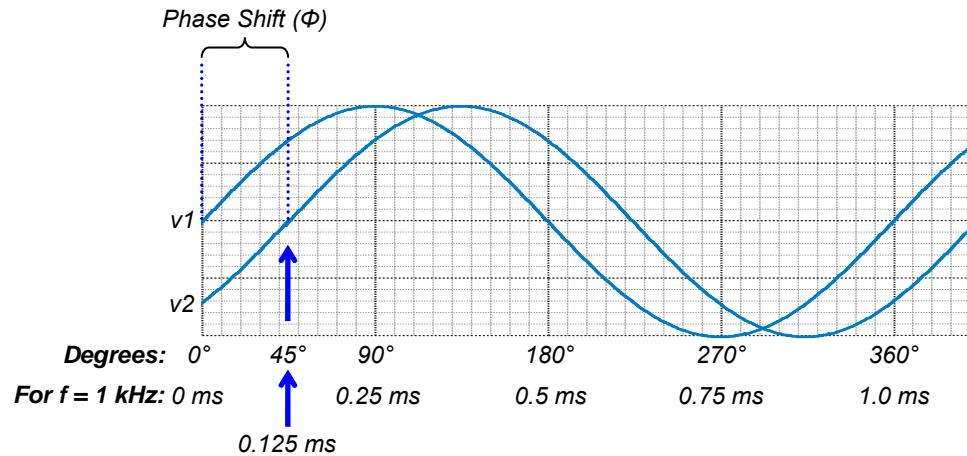

7

Amplitude and Phase Angle Test Parts List

- (1) Resistor – 10 k Ω (brown-black-red)
- (1) Capacitor – 0.01 μF (labeled 103)
- (misc) Jumper wires

3-Digit Capacitor Labeling

Take the first two digits as a two digit number. Multiply it by ten raised to the power of the third digit. Then, multiply that result by 1 pF, which is 1×10^{-12} F. Of the two results in Figure 7-27, 0.01 μF is more common.

Figure 7-27: 3-Digit Capacitor Label

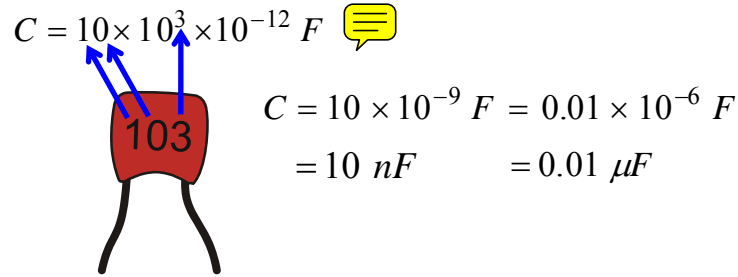

Amplitude and Phase Angle Test Circuit

We'll use the circuit in Figure 7-28 and Figure 7-29 to examine how a circuit can change a sine wave's amplitude and phase. The circuit is similar to the DAC circuit for BASIC Stamp D/A. The PropScope's function generator will apply sine wave signals to the circuit's input, and the PropScope's Oscilloscope view will display the function generator signal as well as the output signal measured on CH1.

- ✓ Set up the CH2 probe hardware to be a function generator output. (See Set DC Voltages with the PropScope's DAC CARD on page 43 for step-by-step instructions.)
- ✓ Build the circuit in Figure 7-28, optionally using Figure 7-29 as a guide.

Figure 7-28: Schematic for Phase Angle Measurement Test

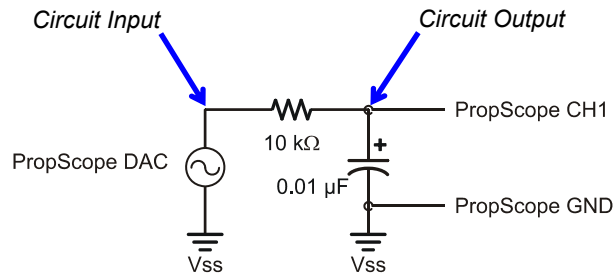
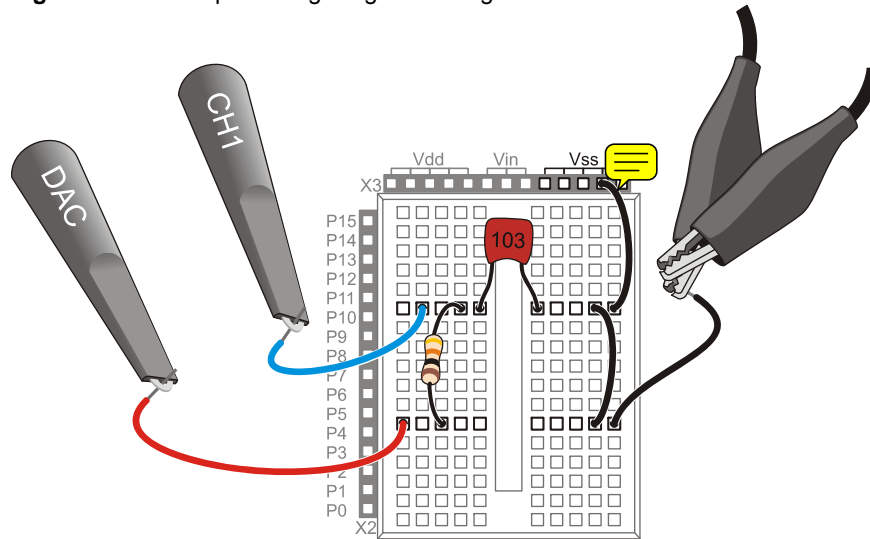

Figure 7-29: Example Wiring Diagram for Figure 7-28



7

Amplitude and Phase Angle Test Measurements

Figure 7-30 shows a sine wave the PropScope DAC CARD's function generator ~~output~~ applies to the RC circuit's input along with the sine wave measured at the circuit's output. The function generator trace is shown as the red, upper CH2 trace, and the circuit's output is measured below it with the blue, CH1 trace. The two waves are positioned close together to highlight the differences in the output signal's amplitude and phase.

Figure 7-30: Visual Phase and Amplitude Check

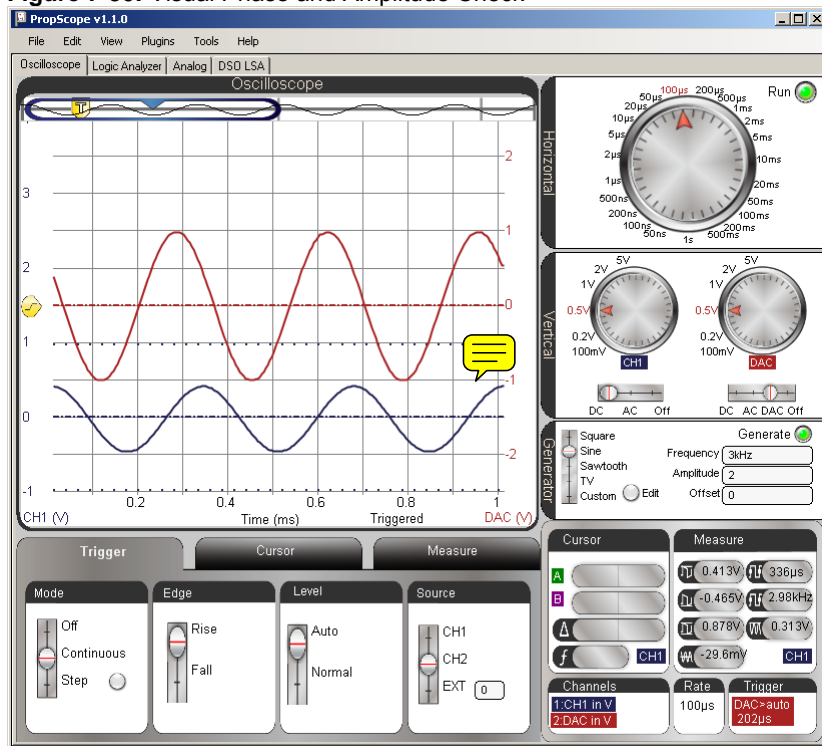

The voltage difference between the output sine wave’s peaks and valleys are shorter than the input signal, so the amplitude is less. In electronics-speak, you could say, “the output signal is attenuated.” Also, the output signal is the same frequency as the input signal, but the whole sine wave appears to be shifted slightly to the right in the Oscilloscope screen. This shift to the right shows that the circuit’s voltage output is somewhat delayed, running behind the input by roughly 1/100th of a millisecond. Again in electronics-speak you could say, “the circuit introduced a phase delay into the output signal.”

- ✓ Adjust the PropScope’s dials to: Horizontal = 100µs/div, Vertical CH1 = 1 V/div, CH2 = 1 V/div.
- ✓ Coupling switches: CH1 = AC, CH2 = DAC.
- ✓ Trigger tab switches: Mode = Continuous, Edge = Rise, Level = Auto, Source = CH1.

- ✓ Trigger Time Control: Align vertical crosshair with 2nd Time Division
- ✓ Generator panel: Function switch = Sine, Frequency = 3 kHz, Amplitude = 2 V, Offset = 0 V.
- ✓ Waveform Positions: Use Figure 7-30 as a guide. Position the red CH2/DAC trace slightly above the blue CH1 trace.

Figure 7-31 shows two different approaches to amplitude measurements, with cursors and with the measure tab.

- ✓ Click the Cursor tab, and then click the Horizontal button to start the voltage cursors.
- ✓ Click the CH2 trace to set the lower-right Cursor and Measure displays to CH2 DAC output. (Or, click the CH1/CH2 label in the Cursor or Measure display to toggle between CH1 and CH2/DAC.)
- ✓ Position one voltage cursor at the tops of the CH2/DAC sine wave's peaks and the other at the bottoms of the valleys.
- ✓ Record the cursor Δ measurement, and compare it to the automated peak-to-peak value in the Measure display.
- ✓ Repeat for CH1.

7

Now we know that the circuit reduces the signal's amplitude by Figure 7-31 by almost $\frac{1}{2}$; $0.867 \div 1.99 \approx 0.436$. Note that the cursor measurements closely match the automated measurements, so for sine wave amplitudes, automated measurements will speed up the process.

Figure 7-31: Amplitude Comparison

Cursor Amplitude Measurement of DAC to Circuit Input on CH2

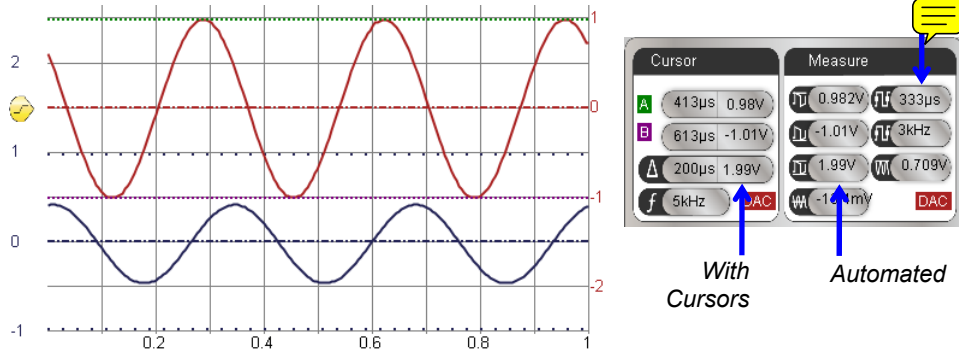

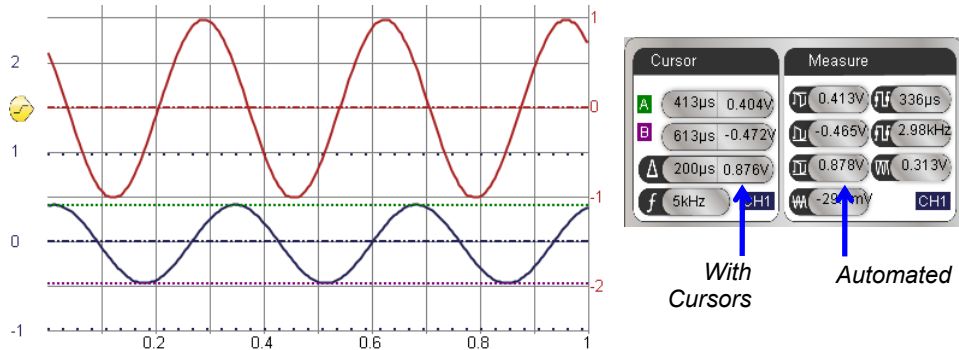

Cursor Amplitude Measurement of Circuit Output on CH1



Next, let's examine the phase delay the circuit introduces by measuring the phase shift. First, we need to measure the time difference Δt between waveforms, and then express it as a number of degrees. The time difference can be measured by picking a point that's common to both signals. With the CH1 coupling set to AC, and CH2 with zero offset, a convenient reference point is where each wave crosses the zero volt line. Figure 7-32 shows the measurement. The Horizontal dial is adjusted to 20 μs for a closer look at the times that the waveforms cross their 0 V lines. Then, cursors are used to measure the time difference.

- ✓ Before adjusting the display, make a note of the signal's period T. (Example in top-left of Figure 7-31 is 333 μs .)
- ✓ Set the Horizontal dial to 20 μs /div.

- ✓ In the Trigger tab, change the Level switch from Auto to Normal.
- ✓ Adjust the Trigger Voltage Control to align with the CH2 ground line.
- ✓ Adjust the Trigger Time control so that the CH2/DAC sine wave rises through the intersection of the ground line and the second time division.
- ✓ In the Cursor tab, click the Horizontal button to remove the voltage cursors, then click the Vertical button to start the time cursors.
- ✓ Adjust the green A  cursor so that it intersects with where the CH2/DAC sine wave crosses the CH2 ground (0 V) line.
- ✓ Adjust the purple B time cursor so that it intersects with where the CH1 sine wave crosses the CH1 ground (0 V) line.
- ✓ Get the phase delay time measurement from the Cursor display's Δ time difference calculation. The example in Figure 7-32 shows a  of about 59.6 μ s.

With the measured Δt of 59.6 μ s and a period T of 333 μ s, the phase delay is:

$$\theta = \frac{\Delta t}{T} \times 360^\circ = \frac{59.6 \mu\text{s}}{333 \mu\text{s}} \times 360^\circ \approx 64.4^\circ$$

7

Figure 7-32: Determine Δt for Phase Comparison

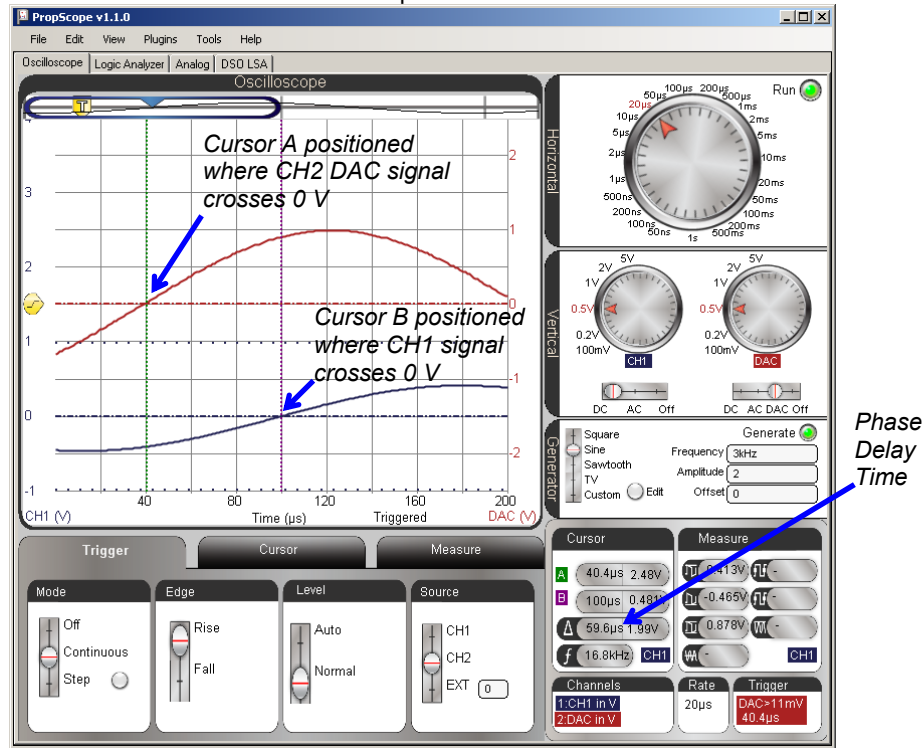

In Figure 7-32, you could actually take the measurement by counting time divisions. The CH2/DAC sine wave crosses the ground line at the 40 μs time division line, and three time divisions later, the CH1 sine wave crosses the 100 μs division line. So the time delay from just counting time divisions is 60 μs , which is close enough to 59.6 μs for this type of measurement.

- ✓ Turn off the cursors and try counting time divisions to measure the phase delay time.

Figure 7-33 shows another common practice for comparing sine waves - superimposing one over another by positioning their ground lines at the same level in the Oscilloscope screen.

- ✓ Try it, and if it works better for you, use it for the next round of phase and amplitude measurements.

Figure 7-33: Sine Waves Superimposed for Comparison

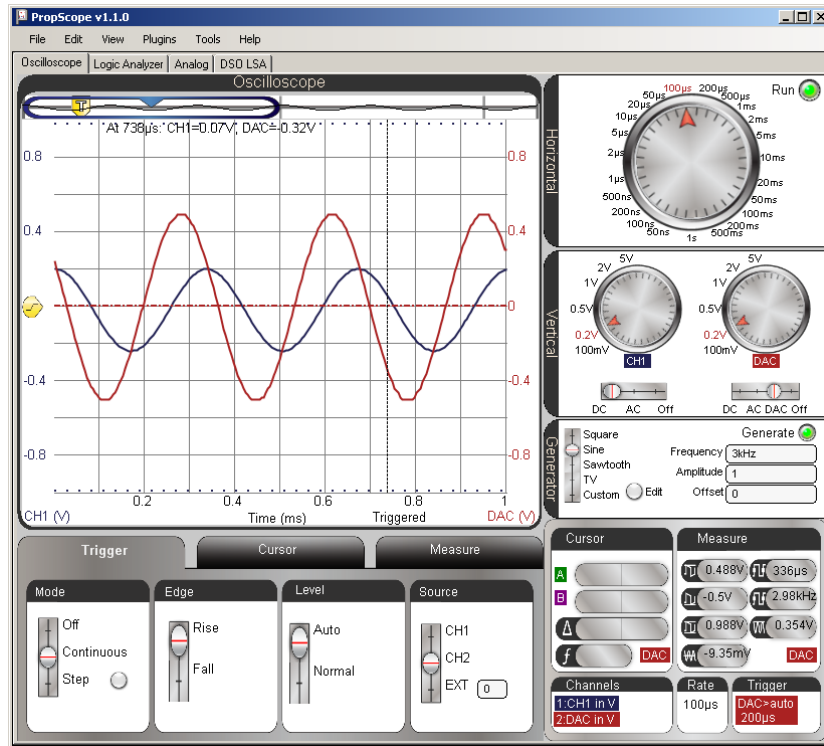

7

Your Turn: What’s Does a “Low Pass Filter” Really Do?

A low pass filter lets low frequencies through and takes away high frequencies by attenuating them (reducing their amplitudes). You will see more about this in the next chapter. For now, let’s just examine the filter’s behavior by trying a lower frequency and a higher frequency. The filter should allow the lower frequency to pass with less attenuation and phase delay. It should also remove more from the higher frequency signal and add to the phase delay.

- ✓ Repeat the amplitude and phase shift measurements in this activity for 1 kHz and 6 kHz. You may need to choose different Horizontal and Vertical settings to accommodate the different amplitudes and frequencies.

SUMMARY

In this chapter, sine waves were displayed with the PropScope and their basic properties of amplitude, frequency, DC offset and phase shift were studied. Practical applications of amplitude and frequency were demonstrated in a tone's volume and pitch. While DC offset doesn't necessarily affect the way a tone sounds in a piezospeaker, it can be problematic for audio speakers. DC offset can also be adjusted to position a sine wave so that it crosses the a microcontroller's I/O pin threshold with each cycle, making it possible for the BASIC Stamp to count cycles and determine frequency.

Musical notes are sine waves of specific frequencies, and the PropScope was used to study the sine waves of individual notes as well as notes played together. In terms of sine waves, two notes played together is equivalent to adding two sine waves together, point-by-point. Given an arbitrary waveform, it can be difficult to determine its sine wave components. The spectrum analyzer is a tool that graphs each of a signal's component frequencies as a bar with a vertical height (amplitude) and horizontal position (frequency).

Two sine waves often have to be compared to each other for amplitude and phase differences. These comparisons are fundamental to numerous circuit analysis and system stability test procedures. As an example of amplitude and phase comparison, the PropScope's function generator was used to apply a signal to the input of an RC low pass filter circuit. Then, the amplitude and phase of a sine wave at the circuit's output was compared to the function generated signal applied to its input. These tests were also performed at several frequencies to examine how the filter lets certain frequencies pass through while blocking others by reducing the signal amplitude at its output.

Questions

1. What are two examples of sine waves that you can hear, see, or feel?
2. What property of a sine wave that drives a speaker determines volume?
3. What are two examples of techniques for measuring a sine wave's amplitude that were covered in this chapter?
4. What units does the PropScope Oscilloscope view's automated measurement features use to report sine wave amplitude?
5. If the pitch of a tone goes down, what happens to the period?

6. If the frequency changed and the sine wave looks less compressed on the oscilloscope screen, what happened to the frequency?
7. If f gets larger, what happens to T ?
8. If you are testing the response of a speaker to frequency, what sine wave property should be held constant and why?
9. What frequency is the E7 note?
10. What kind of signal does the BASIC Stamp use to synthesize sine waves?
11. Where can you find automated sine wave DC offset measurements in the Oscilloscope view?
12. How should voltage cursors be positioned to measure a sine wave's amplitude?
13. What does DTMF stand for?
14. When the BASIC Stamp plays two tones simultaneously, what does it do with the individual sine wave components?
15. If you want to see the DC offset in a sine wave, what kind of coupling do you need to use?
16. What can a spectrum analyzer tell you about a signal?
17. What does a spectrum analyzer's Y axis represent?
18. If you point at a peak in the Spectrum Analyzer screen with your mouse, what PropScope feature automatically reports amplitude and frequency?
19. How does one square wave harmonic differ from the next?
20. If a sine wave enters a circuit like a filter or amplifier, what two attributes might be different at its output?
21. How is phase delay typically quantified?
22. What are two values needed for calculating a phase delay?
23. What's a synonym for a sine wave's period?
24. How does a low pass filter eliminate higher frequencies?

Exercises

1. Explain how to make the PropScope generate a 5 kHz, 3 V_{pp} sine wave.
2. Explain how to generate a 2.5 kHz signal with BASIC Stamp I/O pin P9 that lasts for 10 seconds.
3. Explain how to generate a 2.2 kHz and 3.2 kHz signal at the same time with a BASIC Stamp I/O pin P9 that lasts for 1 second.
4. The peak to peak voltage of a sine wave is 4 V. Calculate the peak amplitude.
5. Calculate the phase angle of a point 41.667 ms into a sine wave with a 0.5 s period.
6. Calculate the phase angle of a point 25 μs into a 5 kHz sine wave.

7. An output sine wave lags behind a 60 Hz input sine wave by 120° . Calculate the time difference between equivalent points on the two sine waves.

Projects

1. Examine the signal a FREQOUT command creates as it transmits a 5 kHz sine wave without a filter and without a piezospeaker. (Just directly probe the I/O pin socket.) Make sure to pick a Horizontal scale that could accommodate a couple cycles of the 5 kHz sine wave even though it won't be visible. The binary signals really won't look like a sine wave, but you can use the Spectrum Analyzer to prove the series of digital binary signals really does contain a sine wave.
2. Write a PBASIC program that combines a 100 Hz signal with a 1 kHz signal. Use different horizontal and vertical scales to determine the frequency and amplitude of each waveform in the Oscilloscope. Verify your results with the Spectrum analyzer.
3. Write a PBASIC program to generate a 3 kHz signal with a beat frequency of 10 Hz. Use FREQOUT 9, 60000, 3000, 3010. Listen to it with the Piezospeaker. Then, examine the 10 Hz beat frequency envelope in the PropScope's Oscilloscope view.

Solutions

- Q1. Examples from this chapter are air pressure variations from a musical instrument playing a note, waves in a pool or at sea.
- Q2. Amplitude.
- Q3. (1) Use the automated Measure display or Measure tab. (2) place cursors at top/bottom of sine wave and check the Cursor display's Δ voltage.
- Q4. Volts-peak-to-peak (Vpp).
- Q5. It decreases.
- Q6. The frequency decreased.
- Q7. T gets smaller.
- Q8. Amplitude should stay the same because it controls the volume for a given frequency. With amplitude held constant, louder or quieter tones at certain frequencies result from properties of the speaker.
- Q9. 2637.0 Hz.
- Q10.  Rapidly alternating high/low signals. More specifically, the BASIC Stamp varies PWM signals with time. The value of the PWM signal's D/A conversion voltage varies according to a sine wave.

- Q11. Check the average voltage value in either the Measure tab or the Measure display.
- Q12. Position one cursor on top of the sine wave's peaks, the other at the bottom of its valleys.
- Q13. Dual tone frequency modulation.
- Q14. It divides each component by 2, then adds them together.
- Q15. DC coupling.
- Q16. The frequencies and amplitudes of its sine wave components.
- Q17. Amplitude.
- Q18. The floating cursor.
- Q19. With each increase in harmonic (and frequency), the harmonic's amplitude decreases.
- Q20. Amplitude and phase.
- Q21. As a degree measure.
- Q22. Either time difference and period or time difference and frequency.
- Q23. Cycle time.
- Q24. By attenuating (reducing the amplitude of) higher frequency sine waves at its output.

7

-  E1. Connect a probe to the DAC CARD's function generator output. In the Generate panel, position function switch at Sine. Enter 5 kHz into the Frequency field, 3 into the Amplitude field. Then, click the Generate button.
- E2. Use the command `FREQOUT 9, 10000, 2500`
- E3. Use the command `FREQOUT 9, 1000, 2200, 3200`
- E4. $V_p = \frac{1}{2} V_{pp} \rightarrow 4 \text{ V} \div 2 = 2 \text{ V}$.
- E5. $\theta = (t/T) \times 360^\circ = 0.041667 \div 0.5 \times 360^\circ = 30^\circ$
- E6. $\theta = t \times f \times 360^\circ \rightarrow \theta = 25 \mu\text{s} \times 2500 \text{ Hz} \times 360^\circ = 45^\circ$
- E7. $T = 1/f = 1/60\text{Hz} = 16.67 \text{ ms}$. $\theta = (t/T) \times 360^\circ \rightarrow t = \theta \times T / 360^\circ = 120^\circ \times 16.67 \text{ ms} / 360^\circ \approx 5.556 \text{ ms}$.
- P1. A modified version of One Note at a Time.bs2 with a `FREQOUT 9, 60000, 5000` command will generate the 5 kHz signal.

```
' One Tone at a Time for CH4P1.bs2
' Play a 5 kHz tone indefinitely.

' {$STAMP BS2}                ' Target module = BASIC Stamp 2
' {$PBASIC 2.5}              ' Language = PBASIC 2.5

DEBUG "Program running..."    ' Debug Terminal message
```

```
DO                               ' Main Loop
  FREQOUT 9, 60000, 5000         ' Play 5000 Hz for 1 minute
LOOP                              ' Repeat main loop
```

Remember that for spectrum analysis, the goal is to examine four to eight cycles of the signal, which would be 5 kHz if there was a filter at the I/O pin's output. $T = 1/f = 1/5\text{kHz} = 200 \mu\text{s}$. Five cycles is convenient because that means we need to see about $1000 \mu\text{s} = 1 \text{ms}$ of horizontal viewing in the PropScope. For $1000 \mu\text{s}$, we need a Horizontal dial setting of $100 \mu\text{s}/\text{div}$. Another tip for spectrum analysis: fill half or more of the vertical display. $1 \text{V}/\text{div}$ will fill half the CH1 vertical display. The CH1 probe should be connected directly to the P9 I/O pin socket. Trigger level should be set to somewhere in the 0 to 5 V range. 2.5 would be ideal.

Figure 7-34: FREQOUT 9, 60000, 5000 Digital Signals and Frequency Component

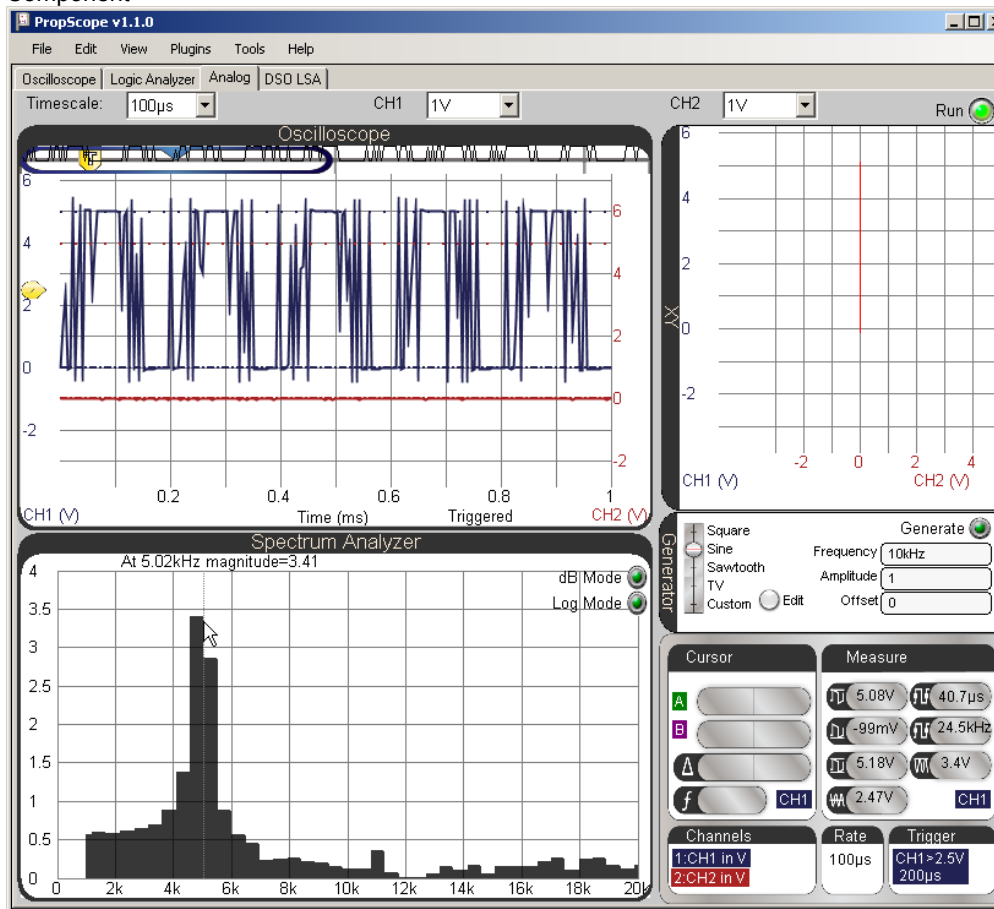

7

P2. Use the circuit from Figure 7-13 and Figure 7-14.

PBASIC Test Code:

```
' Two Tones for CH7P2.bs2
' Play a 100 Hz + 1 kHz indefinitely.

' {$STAMP BS2}           ' Target module = BASIC Stamp 2
```

```

' {$PBASIC 2.5}           ' Language = PBASIC 2.5
DEBUG "Program running..." ' Debug Terminal message
DO                         ' Main Loop
    FREQOUT 9, 60000, 100, 1000 ' Play 100 + 1000 Hz for 1 minute
LOOP                       ' Repeat main loop
    
```

At a glance view of the two waveforms. Note that the trigger level is set to normal and the trigger voltage is set to intersect with a high peak in the waveform. Also, trigger time is set to 2nd division.

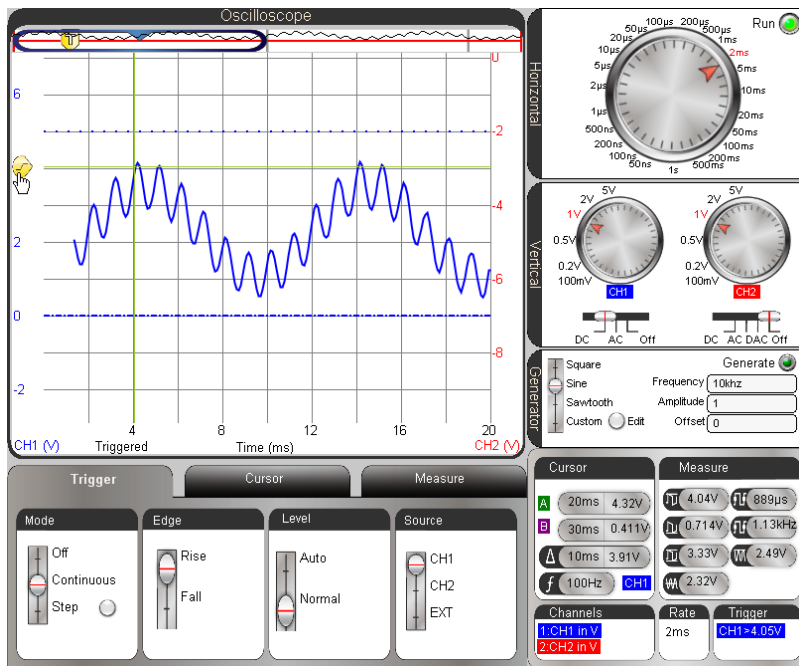

This is a cursor measurement of the 100 Hz waveform with a slightly larger time/division setting. Note Δ and f in the Cursor panel. They are correct, but look at the Measure panel next to it with incorrect values. The automated measure panel was not designed for this type of waveform, so rely on your skills with cursors if it's not just a simple sine or square wave.

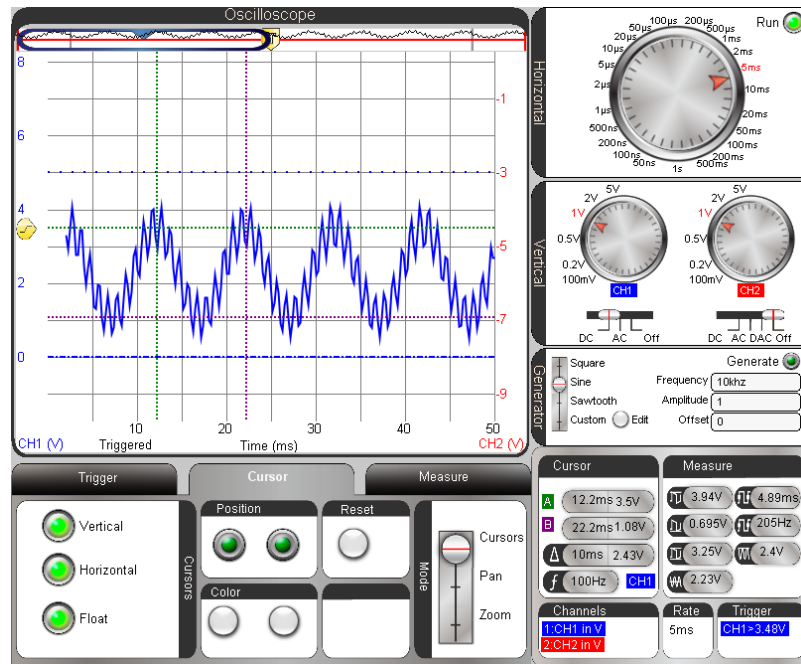

7

This is a cursor measurement of the 1 kHz waveform. Note the difference between the Horizontal dial settings for this measurement and the previous one. Also note that the Δ and f values in the Cursor indicator panel are correct this time.

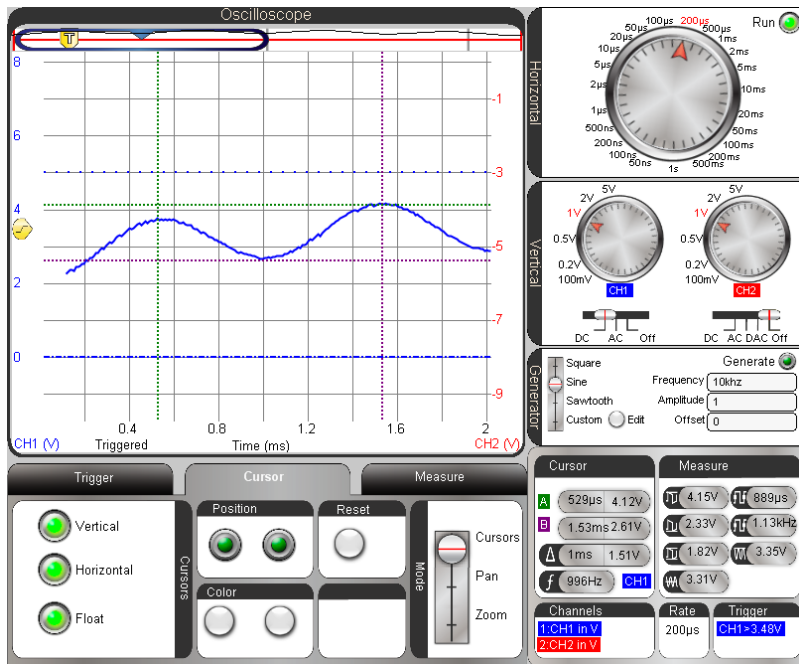

This is a spectrum analyzer check of the waveform. To get the view shown in the Spectrum analyzer panel, you will have to set the Timescale to 2 ms, then point at, grab and hold an empty space in the Spectrum Analyzer screen, and drag it left. This will increase the number of values shown in the frequency scale. We want to spectrum analyzer's horizontal frequency axis to display from 0 to 2 kHz.

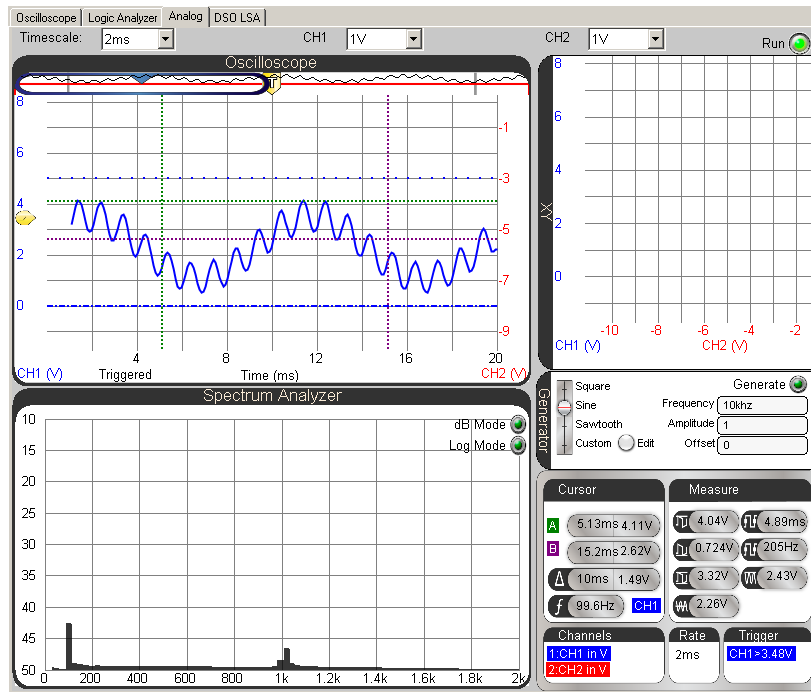

7

P3. Use the circuit from Figure 7-13 and Figure 7-14.

PBASIC Test Code:

```
' Two Tones for CH7P3.bs2
' Play a 3000 Hz + 3010 kHz indefinitely.

' {$STAMP BS2}           ' Target module = BASIC Stamp 2
' {$PBASIC 2.5}         ' Language = PBASIC 2.5

DEBUG "Program running..." ' Debug Terminal message

DO                          ' Main Loop

  FREQOUT 9, 60000, 3000, 3010 ' Play 3000 + 3010 Hz for 1 minute

LOOP                         ' Repeat main loop
```

The 3 kHz signal will get louder and softer at a rate of 10 Hz when you listen to it on the piezospeaker. Note that the time cursors indicate a 10 Hz Measurement in the Cursor panel.

