



ALL SHORE INDUSTRIES, INC.

SPECIFICATION FOR LIQUID CRYSTAL DISPLAY MODULE

MODEL #: ASI_-204BS-IH-_YS/X

Item	Dimension	Unit
Number of Characters	20 characters x 4Lines	-
Module dimension	77.0 x 47.0 x 11.9(MAX)	mm
View area	60.0 x 22.0	mm
Active area	55.1 x 17.56	mm
Dot size	0.46 x 0.42	mm
Dot pitch	0.51 x 0.47	mm
Character size	4.03 x 2.3	mm
Character pitch	4.51 x 2.78	mm
LCD type	STN, Positive, Transflective, Yellow green, Gray	
Duty	1/16	
View direction	6 or 12 o'clock	
Backlight Type	LED Yellow Green	



MODEL NO : ASI_-204BS-IH-_YS/X

RECORDS OF REVISION		DOC . FIRST ISSUE Dec, 2003
DATE	REVISED DRAWING NO.	SUMMARY



MODEL NO : ASI_-204BS-IH-_YS/X

TABLE OF CONTENTS

NO.	ITEM	PAGE
=====		



MODEL NO : ASI_-204BS-IH-_YS/X

LCD MODULE PART NUMBERING SYSTEM

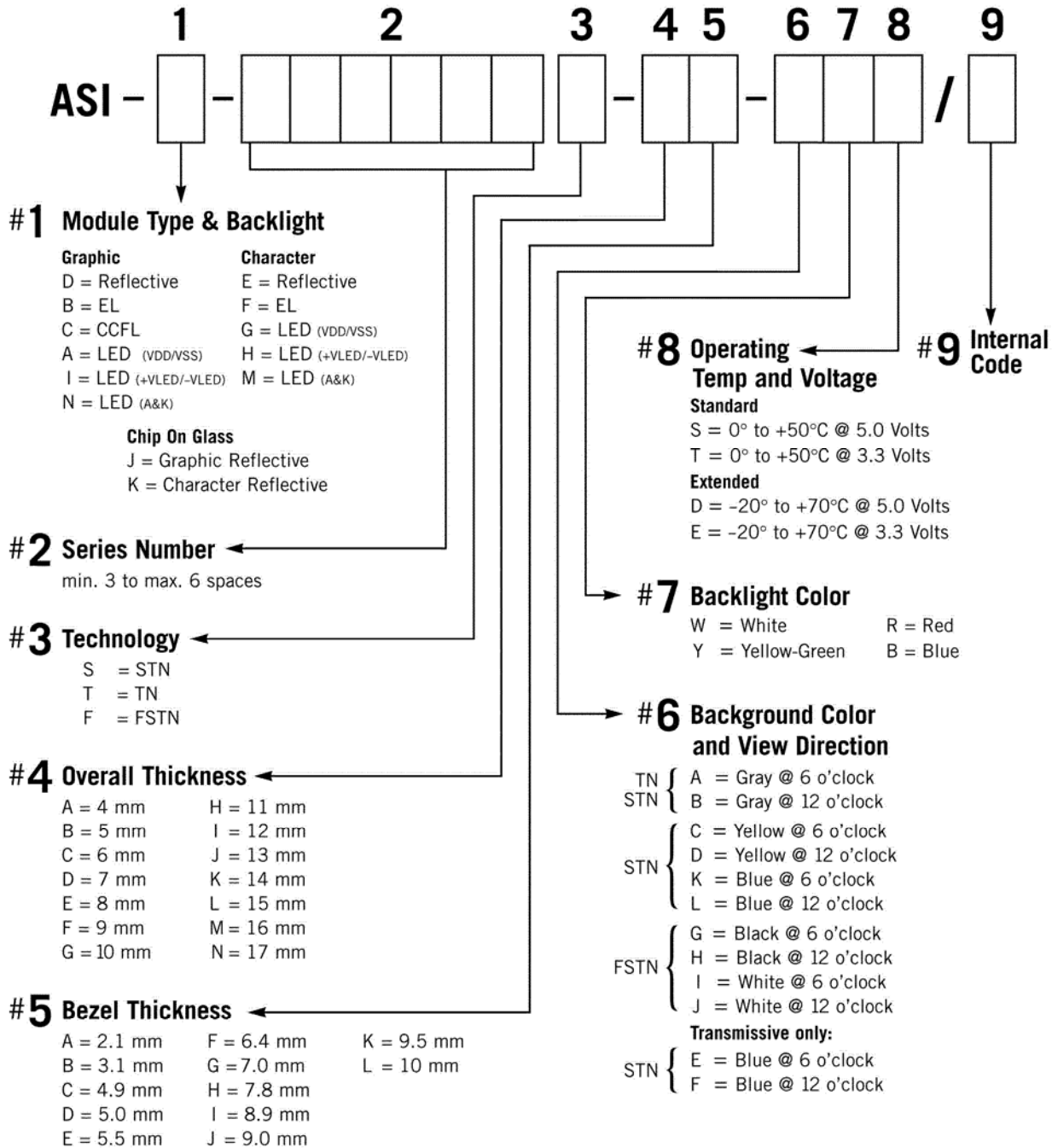

NOTE: Some options may not be available in specific modules. Please contact your Sales Representative to check availability.



MODEL NO : ASI_-204BS-IH-_YS/X

General Specification

Item	Dimension	Unit
Number of Characters	20 characters x 4Lines	-
Module dimension	77.0 x 47.0 x 11.9(MAX)	mm
View area	60.0 x 22.0	mm
Active area	55.1 x 17.56	mm
Dot size	0.46 x 0.42	mm
Dot pitch	0.51 x 0.47	mm
Character size	4.03 x 2.3	mm
Character pitch	4.51 x 2.78	mm
LCD type	STN, Positive, Transflective, Yellow green, Gray	
Duty	1/16	
View direction	6 or 12 o'clock	
Backlight Type	LED Yellow Green	

Absolute Maximum Ratings

Item	Symbol	Min	Typ	Max	Unit
Operating Temperature	T_{OP}	0	-	+50	°C
Storage Temperature	T_{ST}	-10	-	+60	°C
Input Voltage	V_I	V_{SS}	-	V_{DD}	V
Supply Voltage For Logic	$V_{DD}-V_{SS}$	-0.3	-	7	V
Supply Voltage For LCD	$V_{DD}-V_0$	-0.3	-	13	V



MODEL NO : ASI_-204BS-IH-_YS/X

Electrical Characteristics

Item	Symbol	Condition	Min	Typ	Max	Unit
Supply Voltage For Logic	$V_{DD}-V_{SS}$	-	4.5	-	5.5	V
Supply Voltage For LCD	$V_{DD}-V_0$	Ta=-20°C	-	-	6.6	V
		Ta=25°C	-	6.0	-	V
		Ta=70°C	5.4	-	-	V
Input High Volt.	V_{IH}	-	2.2	-	V_{DD}	V
Input Low Volt.	V_{IL}	-	-	-	0.6	V
Output High Volt.	V_{OH}	-	2.4	-	-	V
Output Low Volt.	V_{OL}	-	-	-	0.4	V
Supply Current	I_{DD}	$V_{DD}=5V$	-	1.6	-	mA

Optical Characteristics

Item	Symbol	Condition	Min	Typ	Max	Unit
View Angle	(V) θ	CR \geq 2	10	-	105	deg
	(H) ϕ	CR \geq 2	-30	-	30	deg
Contrast Ratio	CR	-	-	3	-	-
Response Time	T rise	-	-	150	200	ms
	T fall	-	-	150	200	ms

MODEL NO : ASI_-204BS-IH-_YS/X

Definition of Operation Voltage (Vop)

Definition of Response Time (Tr , Tf)

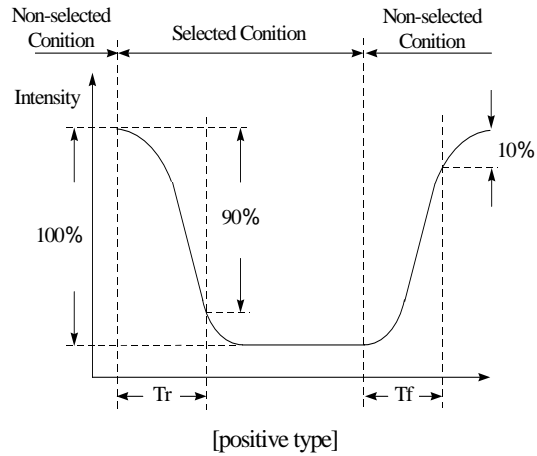
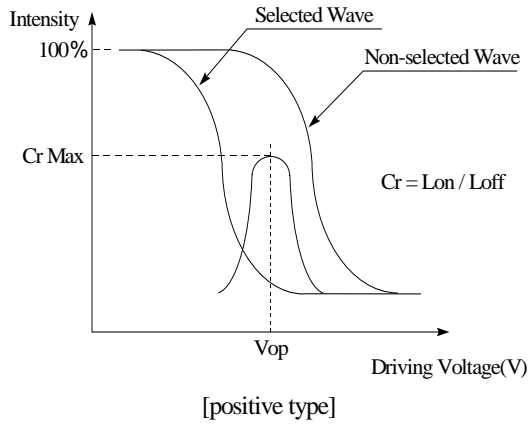

Conditions :

Operating Voltage: Vop

Viewing Angle (θ , ϕ) : 0° , 0°

Frame Frequency: 64 HZ

Driving Waveform: 1/N duty, 1/a bias

Definition of viewing angle(CR 2)

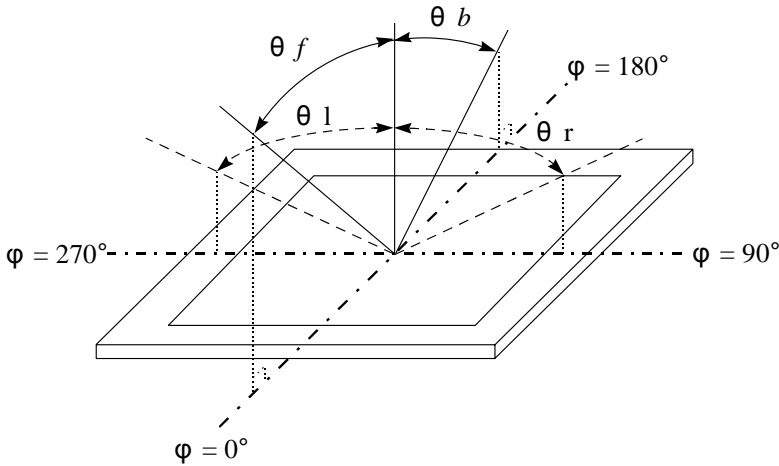



MODEL NO : ASI_-204BS-IH-_YS/X

Interface Pin Function

Pin No.	Symbol	Level	Description
1	V _{SS}	0V	Ground
2	V _{DD}	5.0V	Supply Voltage for logic
3	VO	(Variable)	Operating voltage for LCD
4	RS	H/L	H: DATA, L: Instruction code
5	R/W	H/L	H: Read(MPU→ Module) L: Write(MPU→ Module)
6	E	H,H→ L	Chip enable signal
7	DB0	H/L	Data bit 0
8	DB1	H/L	Data bit 1
9	DB2	H/L	Data bit 2
10	DB3	H/L	Data bit 3
11	DB4	H/L	Data bit 4
12	DB5	H/L	Data bit 5
13	DB6	H/L	Data bit 6
14	DB7	H/L	Data bit 7
15	A	-	4.2 V for LED
16	K	-	Power supply for B/L(0V)



MODEL NO : ASI_-204BS-IH-_YS/X

Contour Drawing & Block Diagram

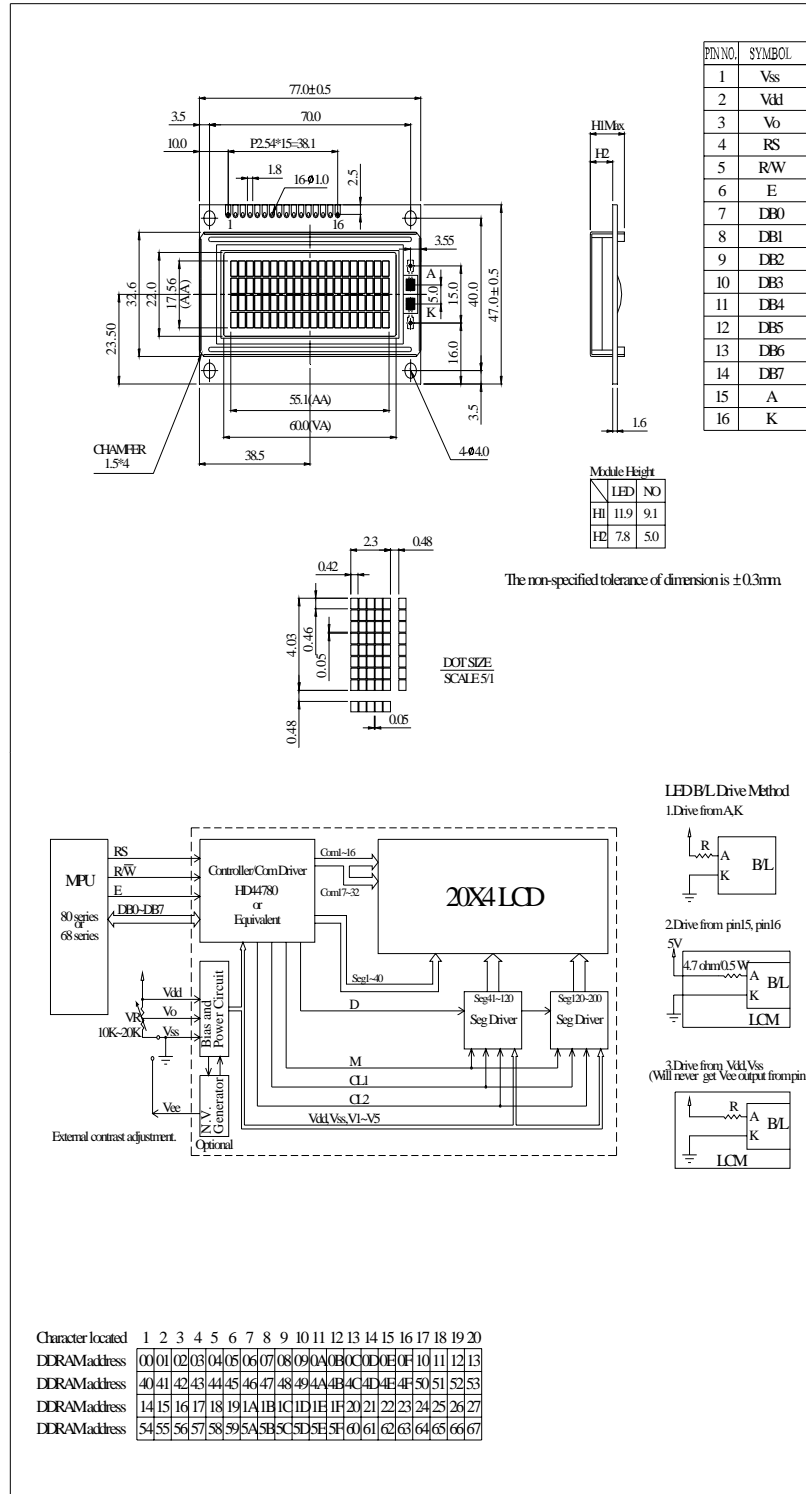



MODEL NO : ASI_-204BS-IH-_YS/X

Function Description

The LCD display Module is built in a LSI controller, the controller has two 8-bit registers, an instruction register (IR) and a data register (DR).

The IR stores instruction codes, such as display clear and cursor shift, and address information for display data RAM (DDRAM) and character generator (CGRAM). The IR can only be written from the MPU. The DR temporarily stores data to be written or read from DDRAM or CGRAM. When address information is written into the IR, then data is stored into the DR from DDRAM or CGRAM. By the register selector (RS) signal, these two registers can be selected.

RS	R/W	Operation
0	0	IR write as an internal operation (display clear, etc.)
0	1	Read busy flag (DB7) and address counter (DB0 to DB7)
1	0	Write data to DDRAM or CGRAM (DR to DDRAM or CGRAM)
1	1	Read data from DDRAM or CGRAM (DDRAM or CGRAM to DR)

Busy Flag (BF)

When the busy flag is 1, the controller LSI is in the internal operation mode, and the next instruction will not be accepted. When RS=0 and R/W=1, the busy flag is output to DB7. The next instruction must be written after ensuring that the busy flag is 0.

Address Counter (AC)

The address counter (AC) assigns addresses to both DDRAM and CGRAM



MODEL NO : ASI_-204BS-IH-_YS/X

Display Data RAM (DDRAM)

This DDRAM is used to store the display data represented in 8-bit character codes. Its extended capacity is 80×8 bits or 80 characters. Below figure is the relationships between DDRAM addresses and positions on the liquid crystal display.

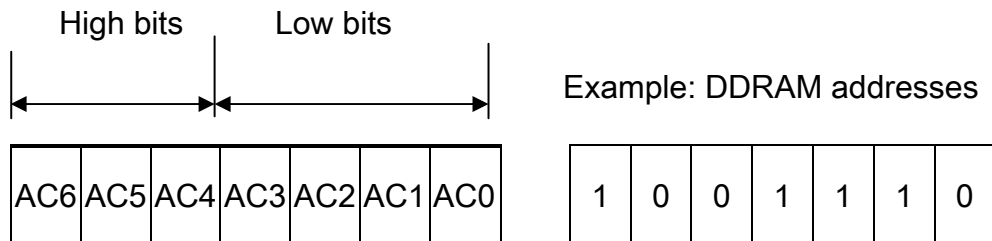

AC
(hexadecimal)



MODEL NO : ASI_-204BS-IH-_YS/X

Display position DDRAM address

1 2 3 4 5 6 7 8 9 10 11 12 13 14 15 16 17 18 19 20

00	01	02	03	04	05	06	07	08	09	0A	0B	0C	0D	0E	0F	10	11	12	13
40	41	42	43	44	45	46	47	48	49	4A	4B	4C	4D	4E	4F	50	51	52	53
14	15	16	17	18	19	1A	1B	1C	1D	1E	1F	20	21	22	23	24	25	26	27
54	55	56	57	58	59	5A	5B	5C	5D	5E	5F	60	61	62	63	64	65	66	67

4-Line by 20-Character Display

Character Generator ROM (CGROM)

The CGROM generate 5×8 dot or 5×10 dot character patterns from 8-bit character codes. See Table 2.

Character Generator RAM (CGRAM)

In CGRAM, the user can rewrite character by program. For 5×8 dots, eight character patterns can be written, and for 5×10 dots, four character patterns can be written.

Write into DDRAM the character code at the addresses shown as the left column of table 1. To show the character patterns stored in CGRAM.



MODEL NO : ASI_-204BS-IH-_YS/X

Relationship between CGRAM Addresses, Character Codes (DDRAM) and Character patterns

Table 1.

For 5 * 8 dot character patterns

Character Codes (DDRAM data)		CGRAM Address		Character Patterns (CGRAM data)		
7 6 5 4 3 2 1 0		5 4 3 2 1 0		7 6 5 4 3 2 1 0		
High Low		High Low		High Low		
0 0 0 0 * 0 0 0		0 0 0	0 0 0	* * *	0	Character pattern(1)
			0 0 1	* * *	0 0 0	
			0 1 0	* * *	0 0 0	
			0 1 1	* * *	0	
			1 0 0	* * *	0 0 0	
			1 0 1	* * *	0 0 0	
			1 1 0	* * *	0 0 0	
			1 1 1	* * *	0 0 0 0 0	
0 0 0 0 * 0 0 1		0 0 1	0 0 0	* * *	0 0 0	Character pattern(2)
			0 0 1	* * *	0 0 0	
			0 1 0	* * *	0 0 0	
			0 1 1	* * *	0 0 0 0 0	
			1 0 0	* * *	0 0 0	
			1 0 1	* * *	0 0 0	
			1 1 0	* * *	0 0 0 0 0	
			1 1 1	* * *	0 0 0 0 0	
			0 0 0	* * *		
			0 0 1	* * *		
0 0 0 0 * 1 1 1		1 1 1	1 0 0			
			1 0 1			
			1 1 0			
			1 1 1	* * *		

For 5 * 10 dot character patterns

Character Codes (DDRAM data)		CGRAM Address		Character Patterns (CGRAM data)		
7 6 5 4 3 2 1 0		5 4 3 2 1 0		7 6 5 4 3 2 1 0		
High Low		High Low		High Low		
0 0 0 0 * 0 0 0		0 0	0 0 0 0	* * *	0 0 0 0 0	Character pattern
			0 0 0 1	* * *	0 0 0 0 0	
			0 0 1 0	* * *	0 0 0 0	
			0 0 1 1	* * *	0 0 0	
			0 1 0 0	* * *	0 0 0	
			0 1 0 1	* * *	0 0 0	
			0 1 1 0	* * *	0 0 0 0	
			0 1 1 1	* * *	0 0 0 0	
			1 0 0 0	* * *	0 0 0 0	
			1 0 0 1	* * *	0 0 0 0	
			1 0 1 0	* * *	0 0 0 0 0	Cursor pattern
			1 1 1 1	* * *	* * * * *	

■ : " High "



MODEL NO : ASI_-204BS-IH-_YS/X

Character Generator ROM Pattern

Table.2



MODEL NO : ASI_-204BS-IH-_YS/X

Upper 4 bit Lower 4 bit	LLLL	LLLH	LLHL	LLHH	LHLL	LHLH	LHHL	LHHH	HLLL	HLLH	HLHL	HLHH	HHLL	HHLH	HHHL	HHHH
LLLL	CG RAM (1)			G	A	P	r					—	0	3	0	0
LLLH	(2)		!	1	A	0	a						7	3	0	0
LLHL	(3)		"	2	B	B	b						4	U	0	0
LLHH	(4)		#	3	S	S	s						U	7	e	e
LHLL	(5)		\$	4	D	T	t						U	T	t	U
LHLH	(6)		%	5	E	U	u						U	*	U	0
LHHL	(7)		&	6	F	U	U						U	U	0	0
LHHH	(8)		'	7	B	U	U						U	*	U	0
HLLL	(1)		(C	H	N	N						U	U	U	U
HLLH	(2))	S	I	V	v						U	U	U	U
HLHL	(3)		*	8	J	Z	z						U	U	U	U
HLHH	(4)		+	9	K	K	k						U	U	U	U
HHLL	(5)		.	<	L	U	U						U	U	U	U
HHLH	(6)		-	=	M	N	n						U	U	U	U
HHHL	(7)		_	>	N	N	n						U	U	U	U
HHHH	(8)		/	?	O	O	0						U	U	U	U

Instruction Table



MODEL NO : ASI_-204BS-IH-_YS/X

Instruction	Instruction Code										Description	Execution time (fosc=270Khz)
	RS	R/W	DB7	DB6	DB5	DB4	DB3	DB2	DB1	DB0		
Clear Display	0	0	0	0	0	0	0	0	0	1	Write "00H" to DDRAM and set DDRAM address to "00H" from AC	1.53ms
Return Home	0	0	0	0	0	0	0	0	1	-	Set DDRAM address to "00H" from AC and return cursor to its original position if shifted. The contents of DDRAM are not changed.	1.53ms
Entry Mode Set	0	0	0	0	0	0	0	1	I/D	SH	Assign cursor moving direction and enable the shift of entire display.	39μ s
Display ON/OFF Control	0	0	0	0	0	0	1	D	C	B	Set display (D), cursor (C), and blinking of cursor (B) on/off control bit.	39μ s
Cursor or Display Shift	0	0	0	0	0	1	S/C	R/L	-	-	Set cursor moving and display shift control bit, and the direction, without changing of DDRAM data.	39μ s
Function Set	0	0	0	0	1	DL	N	F	-	-	Set interface data length (DL:8-bit/4-bit), numbers of display line (N:2-line/1-line)and, display font type (F:5×11 dots/5×8 dots)	39μ s
Set CGRAM Address	0	0	0	1	AC5	AC4	AC3	AC2	AC1	AC0	Set CGRAM address in address counter.	39μ s
Set DDRAM Address	0	0	1	AC6	AC5	AC4	AC3	AC2	AC1	AC0	Set DDRAM address in address counter.	39μ s
Read Busy Flag and Address	0	1	BF	AC6	AC5	AC4	AC3	AC2	AC1	AC0	Whether during internal operation or not can be known by reading BF. The contents of address counter can also be read.	0μ s
Write Data to RAM	1	0	D7	D6	D5	D4	D3	D2	D1	D0	Write data into internal RAM (DDRAM/CGRAM).	43μ s
Read Data from RAM	1	1	D7	D6	D5	D4	D3	D2	D1	D0	Read data from internal RAM (DDRAM/CGRAM).	43μ s

* " - " : don't care



MODEL NO : ASI_-204BS-IH-_YS/X

Timing Characteristics

12.1 Write Operation

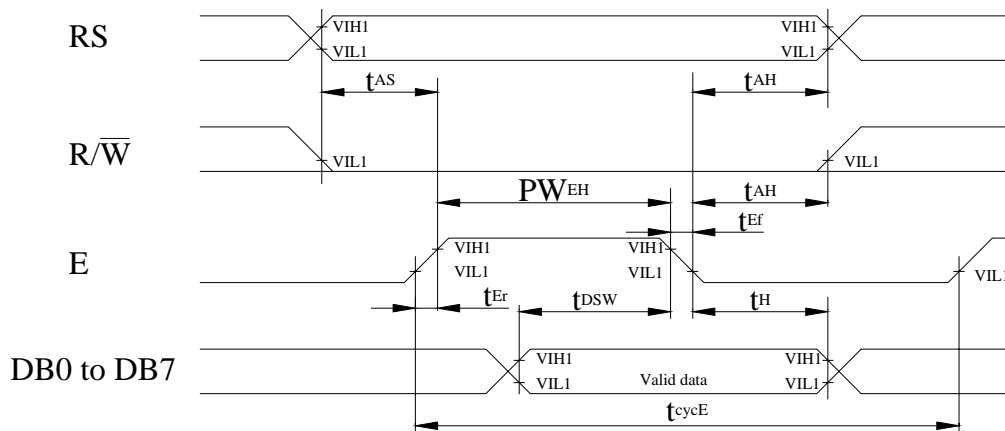

$T_a=25^{\circ}\text{C}$, $V_{DD}=5.0\pm 0.5\text{V}$

Item	Symbol	Min	Typ	Max	Unit
Enable cycle time	t_{cycE}	1200	-	-	ns
Enable pulse width (high level)	PW_{EH}	140	-	-	ns
Enable rise/fall time	$t_{\text{Er}}, t_{\text{Ef}}$	-	-	25	ns
Address set-up time (RS, R/W to E)	t_{AS}	0	-	-	ns
Address hold time	t_{AH}	10	-	-	ns
Data set-up time	t_{DSW}	40	-	-	ns
Data hold time	t_{H}	10	-	-	ns



MODEL NO : ASI_-204BS-IH-_YS/X

12.2 Read Operation

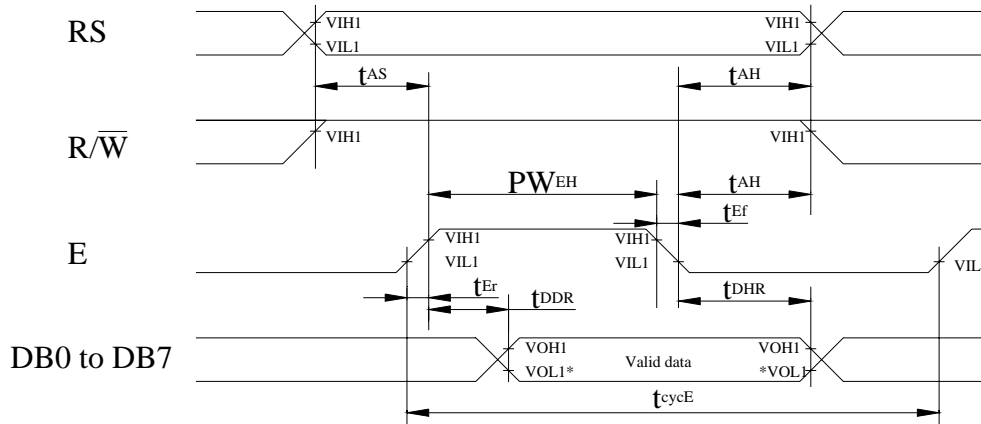

NOTE: *VOL1 is assumed to be 0.8V at 2 MHz operation.

$T_a=25^{\circ}C$, $V_{DD}=5.0 \pm 0.5V$

Item	Symbol	Min	Typ	Max	Unit
Enable cycle time	t_{cycE}	1200	-	-	ns
Enable pulse width (high level)	PW_{EH}	140	-	-	ns
Enable rise/fall time	t_{Er}, t_{Ef}	-	-	25	ns
Address set-up time (RS, R/W to E)	t_{AS}	0	-	-	ns
Address hold time	t_{AH}	10	-	-	ns
Data delay time	t_{DDR}	-	-	100	ns
Data hold time	t_{DHR}	10	-	-	ns



MODEL NO : ASI_-204BS-IH-_YS/X

Initializing of LCM

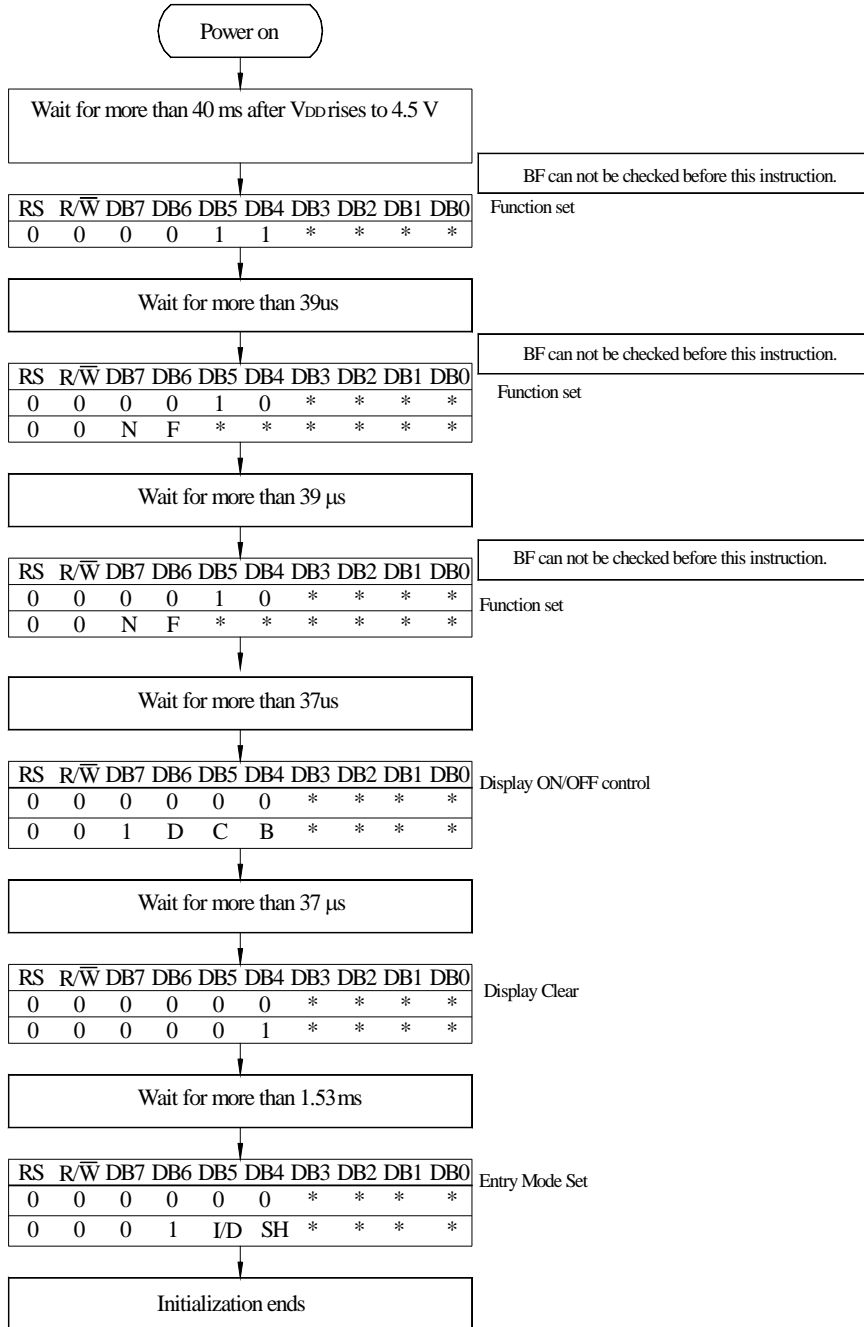

4-Bit Ineterface



MODEL NO : ASI_-204BS-IH-_YS/X

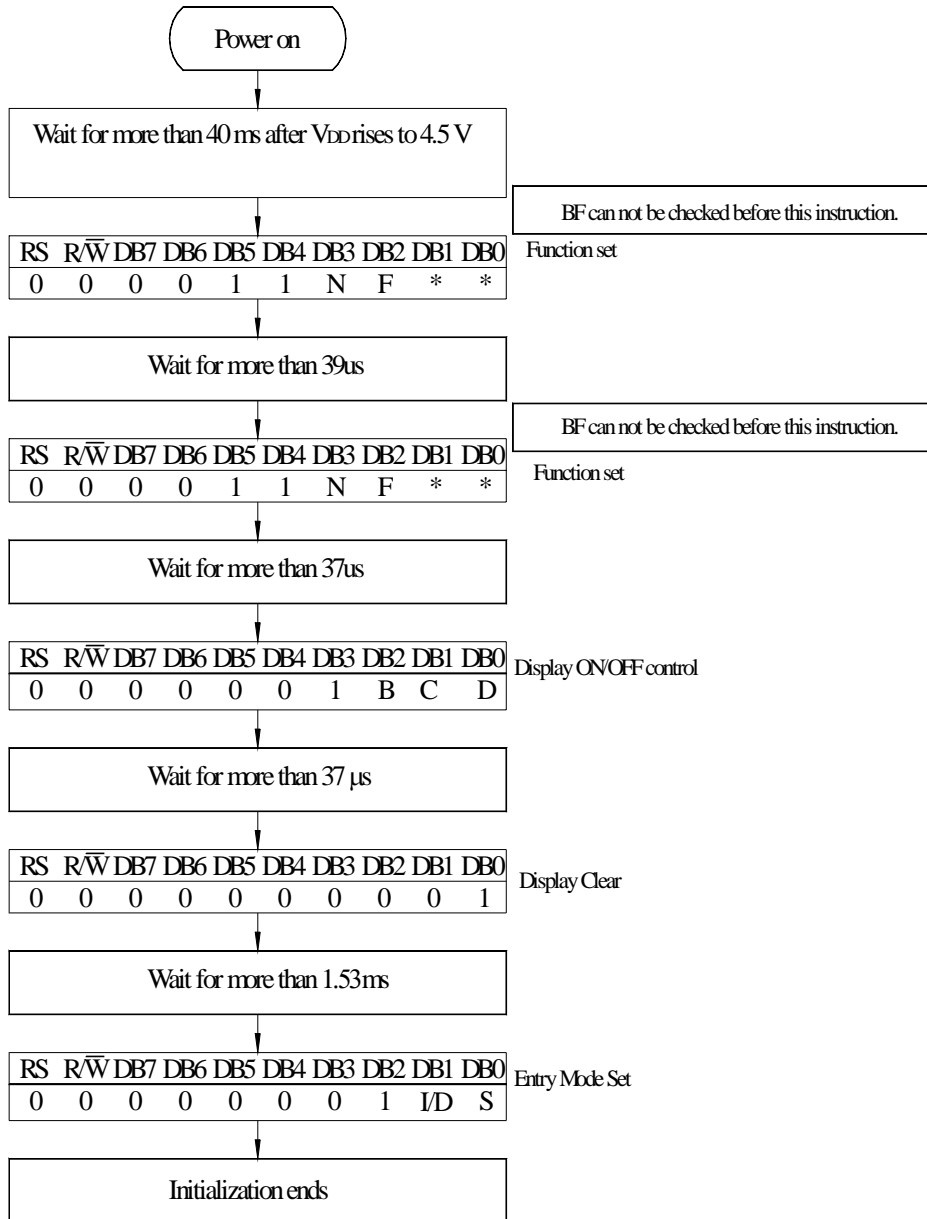

8-Bit Interface



MODEL NO : ASI_-204BS-IH-_YS/X

14. Quality Assurance

Screen Cosmetic Criteria

Item	Defect	Judgment Criterion	Partition
1	Spots	<p>A)Clear</p> <p><u>Size: d mm</u> <u>Acceptable Qty in active area</u></p> <p>$d \leq 0.1$ Disregard</p> <p>$0.1 < d \leq 0.2$ 6</p> <p>$0.2 < d \leq 0.3$ 2</p> <p>$0.3 < d$ 0</p> <p>Note: Including pin holes and defective dots which must be within one pixel size.</p> <p>B)Unclear</p> <p><u>Size: d mm</u> <u>Acceptable Qty in active area</u></p> <p>$d \leq 0.2$ Disregard</p> <p>$0.2 < d \leq 0.5$ 6</p> <p>$0.5 < d \leq 0.7$ 2</p> <p>$0.7 < d$ 0</p>	Minor
2	Bubbles in Polarize	<p><u>Size: d mm</u> <u>Acceptable Qty in active area</u></p> <p>$d \leq 0.3$ Disregard</p> <p>$0.3 < d \leq 1.0$ 3</p> <p>$1.0 < d \leq 1.5$ 1</p> <p>$1.5 < d$ 0</p>	Minor
3	Scratch	In accordance with spots cosmetic criteria. When the light reflects on the panel surface, the scratches are not to be remarkable.	Minor
4	Allowable Density	Above defects should be separated more than 30mm each other.	Minor
5	Coloration	Not to be noticeable coloration in the viewing area of the LCD panels. Back-light type should be judged with back-light on state only.	Minor



MODEL NO : ASI_-204BS-IH-_YS/X

Reliability

Content of Reliability Test

Environmental Test			
Test Item	Content of Test	Test Condition	Applicable Standard
High Temperature storage	Endurance test applying the high storage temperature for a long time.	60°C 200hrs	—
Low Temperature storage	Endurance test applying the high storage temperature for a long time.	-10°C 200hrs	—
High Temperature Operation	Endurance test applying the electric stress (Voltage & Current) and the thermal stress to the element for a long time.	50°C 200hrs	—
Low Temperature Operation	Endurance test applying the electric stress under low temperature for a long time.	0°C 200hrs	—
High Temperature/ Humidity Storage	Endurance test applying the high temperature and high humidity storage for a long time.	60°C,90%RH 96hrs	—
High Temperature/ Humidity Operation	Endurance test applying the electric stress (Voltage & Current) and temperature / humidity stress to the element for a long time.	50°C,90%RH 96hrs	—
Temperature Cycle	Endurance test applying the low and high temperature cycle. 	-10°C/60°C 10 cycles	—
Mechanical Test			
Vibration test	Endurance test applying the vibration during transportation and using.	10~22Hz→ 1.5mmp-p 22~500Hz→ 1.5G Total 0.5hrs	—
Shock test	Constructional and mechanical endurance test applying the shock during transportation.	50G Half sign wave 11 msedc 3 times of each direction	—
Atmospheric pressure test	Endurance test applying the atmospheric pressure during transportation by air.	115mbar 40hrs	—
Others			
Static electricity test	Endurance test applying the electric stress to the terminal.	VS=800V,RS=1.5kΩ CS=100pF 1 time	—

***Supply voltage for logic system=5V. Supply voltage for LCD system =Operating voltage at 25°C



MODEL NO : ASI_-204BS-IH-_YS/X

16.Backlight Information

Specification

PARAMETER	SYMBOL	MIN	TYP	MAX	UNIT	TEST CONDITION
Supply Current	I _{LED}	—	120	180	mA	V=4.2V
Supply Voltage	V	-	4.2	4.6	V	-
Reverse Voltage	V _R	-	-	8	V	-
Luminous Intensity	I _V	120	180	-	CD/M ²	I _{LED} =120mA
Wave Length	λ _p	570	573	576	nm	I _{LED} =120mA
Life Time	-	-	100000	-	Hr.	V ≤ 4.6V
Color	Yellow Green					

The information presented in this datasheet has been carefully checked and is believed to be accurate; however, no responsibility is assumed for inaccuracies. Information contained herein is for selection purposes only, and is subject to change without notice. Please contact ASI for current datasheets prior to designing.