



Penguin Tech

BASIC STAMP POWER *premier edition 1*



robots, code, and the basic stamp microcontroller

by humanoido



Penguin Tech is Born!

FOCUS

- Premier Edition!
- Build a Tiny BOE
- Code Versions
- Penguin Fingers
- Vibra Tab Mass
- PBASIC Techniques
- Eric Rodemeyer Interview
- Pocket Penguin
- Penguin Kit Tips
- Free Penguin Code
- About Penguin
- Penguin Society

PT is an independent non-profit publication (although donations are accepted to help us continue) and has no appreciable timetable. PT is a spin-off contribution of Penguin Robot Society. Issues are released internationally when interesting projects become available and documented for everyone to enjoy. Material, ideas, concepts, and drawings, may be used for your own personal projects for home and school use, unless otherwise noted. Although information is presented from working projects, it is to be considered "as is" and up to the user to determine suitability. The user assumes all risk and liability. The best support is currently through the Parallax Forum found online at <http://forums.parallax.com/forums>

Special thanks to Ken Gracey and the Parallax support team. For more information, contact the editor, humanoido, at email: penguin.robot@yahoo.com

Welcome to the Premier Edition of **Penguin Tech!** I'm humanoido, creator of the independent **Penguin Tech Magazine**. **PT** is born out of a need to document useful information about Penguin Robot, the Basic Stamp series of micro controllers, PBASIC code, techniques, tips and useful data. **PT** is packed with fascinating hobby projects, useful information and really cool DIY stuff. Over the next series of electronic published full color issues, I plan to include the projects you've been wishing and waiting

for. Within the bounds of these dream pages, there's emphasis on simplicity and different stamp versions. The amazing Penguin Robot is at the top of our interest list and many Penguin projects can be recreated with other basic stamps in the product line. Penguin/Basic Stamp is the focus here. What about other processors? While anyone could spend hundreds of hours of development time with tens of thousands of labor dollars, riddled with complicated problems with other processors, we prefer the more easy route with a

processor that's well documented and well supported. The Basic Stamp is the shining gem for easy circuit building and programming enjoyment. Get ready to tap into an enormous support base of remarkable technology. **PT** is a labor of love. The aim is to include fun and easy small desktop projects affordable to the hobbyist and student on a low budget - hardware, software, or something wildly creative, even unimaginable. So stay tuned to issues of our top publishing **Penguin Tech** magazine! •

How to Build a Tiny BOE

BOE is the Board of Education, from Parallax Inc. It's a development board on which to build many interesting basic stamp projects and it can be used over and over again, due to its convenient solderless breadboard and pin-out connectors. BOE is also the board driving the popular BOEBOT robot. BOE's uses are many, from controlling servos to offering convenient power regulation, a reset switch, and various well

labeled connectors. BOE is the instrument by which you can get your projects running quickly and effectively. However, BOE is small but not tiny. It would be nice to have a tiny boe for robots smaller than BoeBot, such as Penguin Robot, and other projects with limited space requirements. This article examines a way to create a tiny BOE. This tiny BOE is portable and convenient, operating off the well known OEM Basic Stamp 2.

Mainly, we connected an edge board connector and added a tiny solderless breadboard using double stick tape (the kind to connect picture frames to the wall). Wiring is accomplished by leading wires from the edge connector to the breadboard. There are many applications for Tiny Boe. You can even make a Tiny BoeBot. It's recommended to first make some standard connections for reset, and power.





Step by Step Tiny Boe Assembly

- Step 1:** Collect the parts in the list and in the photo shown to the left.
Step 2: Assemble a BS2 OEM and confirm it's working with sample code.
Step 3: Attach a solderless breadboard as shown using double stick tape.
Step 4: Run wires from the edge socket for reset, +5v, and ground.
Step 5: Tiny Boe is ready for wiring using its tiny solderless breadboard.

Tiny BOE uses a Basic Stamp OEM kit and a few extra parts. As seen in the photos below, Tiny Boe fits well into several orientations. It's recommended to have the heat sink towards the top for best heat dissipation. Follow the downloadable OEM instructions for a power supply.

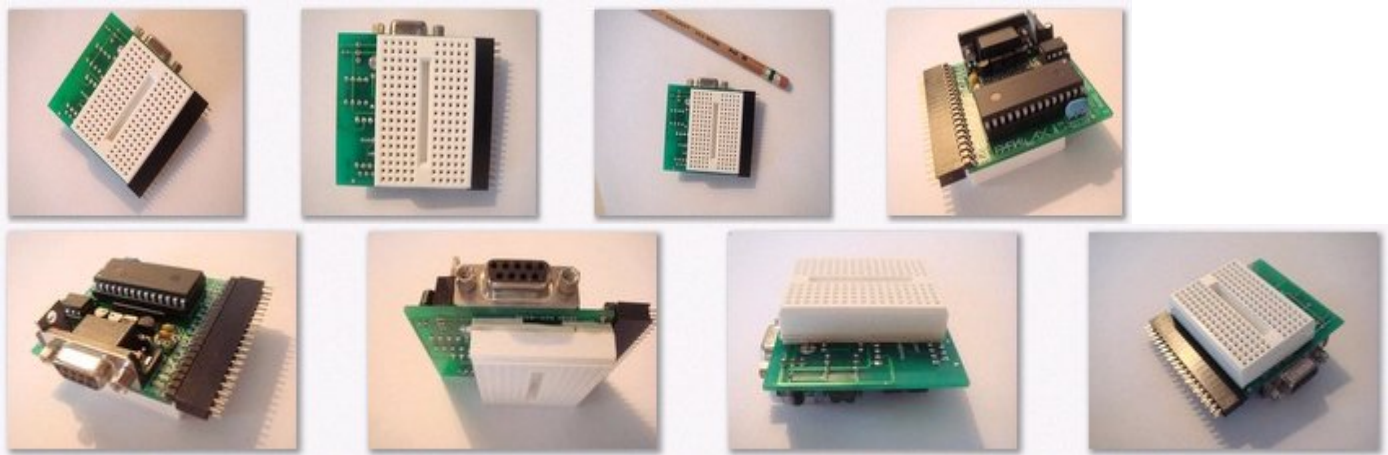

Tiny BOE Parts List

- 1 – Solderless breadboard
- 1 – BS2 OEM
- 1 – Edge connector for BS2
- 1 – Double stick tape

Using the Tiny Boe is actually a lot of fun. Pin space on the breadboard is at a premium so be sure to plan projects carefully for the most efficient use of point to point wiring. The Parallax solderless breadboard has thirty-four 5-pin rows available. For more project space, the power connectors and reset switch can be offloaded from the breadboard. Tiny Boe was originally conceived as a robotics project for a tiny BoeBot and a tiny coprocessor Boe for Penguin Robot. ●

Check Your Parallax Penguin Robot Code Version!

As of this writing, Parallax Inc. revised Penguin Robot software, including calibration code. Calibrated values of tilt and stride are stored in new different memory locations!

The standard has been changed! If you want to run any of the hundreds of previous programs, they either will not run or you'll

need to use the calibration program from the *Humanoido Penguin Robot Suite of software*, such as the **automatic servo calibrator** program. A list for downloads and the locations are provided within this magazine. See "[A Guide to Humanoido's Penguin Robot Code](#)" on page 7. Rumor has it that discussion is currently going on at Parallax Inc. to change these

calibration memory locations back to their original intended positions. We applaud this idea.

Note: the introduction of calibration values for constants other than tilt and stride, such as speed, may be highly program specific. You'll need to keep a watchful eye on all storage areas and not overwrite their memory locations! ●

"you'll need the calibration program from the Humanoido Penguin Robot Suite of software..."



How I built Hand Fingers for Penguin Robot using Vibra Tab Mass

I searched the World looking for some hand finger sensors that could work with my Penguin Robot.

I looked for low cost hobby sensors, Basic Stamp compatibility, weigh almost nothing, easy to use and programs in PBASIC. My search found success with the Peizo Vibra Film Tab Mass, offered by Parallax. This tiny sensor weighs almost nothing, costs only \$1.79 each, at the time of this project, and interfacing is very easy. With this article, I can show you how to create a simple circuit and use simple software to make hand fingers for Penguin Robot. I experimented with several circuits and settled

on the one shown here which uses RC. Also shown below is the full PBASIC code for one finger. Multiple fingers can be added in loops. Note, the development circuit and software is designed around the Basic Stamp 2 Homework Board, for ease of construction. This board already has a 220 ohm resistor in series with each port. Compensate the circuit when using other prototyping boards. The timing on the BS2px on Penguin Robot is substantially faster and well suited for expanding with more fingers. The down-loaded Parallax sensor documentation details the software for using the sensor as an on/off switch. Although this works well,

the experiment here will show how to return a more useful stream of numbers based on the compression action of the sensor. The circuit will also protect against the high voltage created by the sensor, using a 5.1 volt zener diode.

By humanoido

Penguin Robot Hand Finger uses a Peizo Film Vibra Tab Mass LDTO, available from Parallax. Note a 5.1 volt zener diode and .01uf 50v capacitor are the only two support parts required. HomeWork board ports have a 220 ohm resistor in series for protection. If prototyping with other boards, add the resistor.

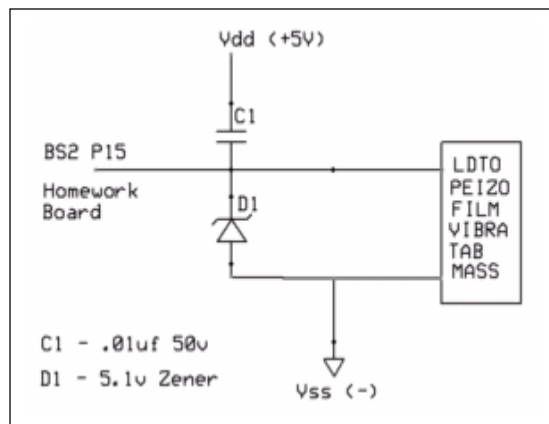

PBASIC Software for a Vibra Tab Mass Finger

```

'----- Titles -----
' Title      Vibra Tab Mass Hand Finger
' Code Name  finger.bs2
' Purpose    Working finger based on Vibra Tab Mass sensor
' Author     humanoido
' Version    1.1
' Begin      02 May 2008
' Update     01 August 2008
' Hardware   Basic Stamp Homework Board
             Peizo Film Vibra Tab Mass LDTO

'----- Directives -----
'{$STAMP BS2}
'{$PBASIC 2.5}

'----- Declarations -----
raw      VAR   Word      ' Stores raw output
sensorPin CON  15       ' Vibra Film Tab Mass sensor circuit
force    VAR   Word

'----- Descriptions -----
' Vibra Film Tab Mass Sensor program
' Piezo Film Vibra Tab Mass Parallax #605-00004

' This Piezo Film Vibra Tab Sensor is the LDTO Solid State

' Switch/Vibration Sensor manufactured by Measurement Specialties.
' The LDTO is a piezoelectric film device capable of acting as switch
' or vibration sensor.

' A working finger sensor designed for Penguin Robot

' * Low Cost
' * Light Weight
' * Simple Code
' * Easy RC Circuit
' * Uses only 1 sensor and 2 parts (diode, capacitor)

' Displays R/C Discharge Time in the BASIC Stamp DEBUG Window
' and shows conditioned output updated in real time
' Places the sensor in one rc circuit for one finger
' Use pin 15, conditioned numbers will be less than 1000

'----- Main program -----

Measure:
HIGH sensorPin      ' Discharge the capacitor
PAUSE 20            ' Delay
RCTIME sensorPin,1,raw ' Measure RC charge time
force = raw/100     ' Condition the raw output
DEBUG HOME, "ROBOT FINGER", CR, CR, " Vibra Film Tab Mass Raw Output = ", DEC raw, CR
DEBUG " Conditioned Value      = ", DEC force, CR
GOTO Measure
    
```



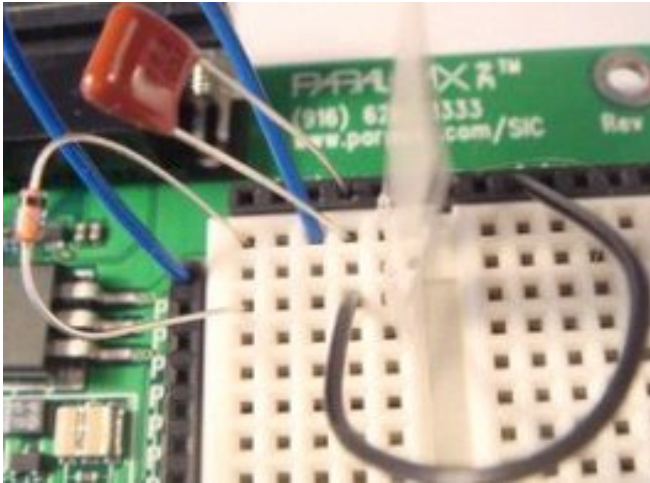

Wiring for one Penguin Robot finger using a Basic Stamp OEM kit and a few extra components. All parts are from Parallax Inc.

Hand Fingers Continued
Wiring the Robot Finger using the Peizo Vibra Film Tab Mass (LTDO) is a breeze using the Basic Stamp HomeWork Board. Note the 5.1 volt zener diode at left, followed by a .01uf 50 volt poly capacitor going to Vdd (+5v) and the far leg of LTDO. The blue wire connects port P15 to the far leg of LTDO. The black wire connects (-) Vss to near leg of LTDO. Use care in connecting the sensor legs to the solderless breadboard. Hold the leg from both sides, perpendicular, and firmly press into the board.

Refer to the parts list, photo and wiring diagram to complete this project. ●

Robot Finger Parts List

- 1 – Capacitor .01uf 50v
- 1 – Zener Diode 5.1v
- 1 – HomeWork Board
- 2 – Wire Jumpers
- 1 – LTDO Vibra Tab Mass

Penguin Program Grab Bag

PBASIC Guidelines, Sample Code, Techniques

With many versions of BASIC language, if you've programmed in several, the exact syntax can become confusing. The best way to keep track of developing code with various dialects is to create some code guides, samples and examples. This is exactly what we'll do in this section. Let's begin by listing some code rules and techniques, which can be used as reference when programming Penguin Robot in PBASIC.

“Let's begin by listing some code rules and techniques, which can be used as reference when programming Penguin Robot in PBASIC”

Pin Symbolic Name Assignments

A good programming practice is to assign symbolic names to all pins and then write the code to use the names. Using this method, any future changes in the layout of the circuit only requires you to change the symbolic definitions and the rest of the code will remain unchanged.

	Value Range Bit/Nibble/Byte/Word
Bit	0 – 1
Nib	0 – 15
Byte	0 - 255
Word	0 - 65535

Example of Pin Symbolic Names

TxSig	PIN 0
RxFlg	PIN 1

Use LOOP or STOP instead of END
If the program ends, the BASIC Stamp will be in low power mode and wake up every 2.13 seconds for 18ms causing a momentary glitch on any I/O lines that were set to outputs. The cure here is to not let the program end (typical programs loop indefinitely) or use a STOP command at the end.

PBASIC Syntax

Variable Name	waterLeve	VAR	Word
Constants	AlarmCode	CON	25
Program Label	Calculate_Space:		
Keywords (upper case)	CON, VAR, PIN, DEC, STOP		



Interview with Eric Rodemeyer Penguin Robot Master

PT has the exclusive interview with Penguin Robot enthusiast Eric Rodemeyer. Eric master-crafted his own Penguin Robot before Parallax began production!

Eric comments: “The actual build was not that difficult. I built a small mill out of particle board and skateboard bearings for doing these little projects. I feel this really helped give it the nice finished look that it has.”

What other robots did you build prior to Penguin?

A Hero Jr. that was partially completed when I got it.

What inspired you to DIY-build a Penguin robot?

The fact that few had taken the time to build when all the info was available to them.

Can you briefly tell us about assembly?

Using the measurements provided by Parallax, I entered those and the offset for the mill bit and went to work. Ken Gracey provided all the details needed and plenty of drawings and pictures.

When was your Penguin

built?

Completed the Penguin 8-15-2006

Can you tell us about the microcontroller used and the features it has?

IR, CDC, Compass, speaker, SX48 based. I was lucky as Ken Gracey provided me with the prototype board and battery holder.

What are Penguin’s best features?

Size, style and compass

What comments did you receive about Penguin from other robot hobbyists?

Everyone I have run across has had a positive comment. Many are interested in buying a prefab kit form of the Penguin.

Did you get to the point of writing any software in PBASIC?

Parallax has documented their products so well that all the features are covered by demo code. It is simply a matter of slight modification to the code to get the results that you want.

What applications interest you the most with Penguin? In other words, what can you make it do, and what do you wish it could do?

Given its size and the features it

has, it does all I could ask for.

Do you know of anyone else building a Penguin robot?

I do not know of anyone else.

Do you have any ideas for expanding the bot?

Possibly edge detection so he will stay on a table

What advice can you give other Penguin enthusiasts about building their own?

Take your time and ask questions if you have problems.

If you could build it over again, what things would you do differently and why?

I would probably do something different with the foot lift linkage, something smaller than the current ball ends as even the 4-40 rod looks big for this bot. This setup was the best I could source at the time.

If you could write more programs, what would you envision?

Something that would show off the compass module, keep a heading and work around road blocks.

What does the future hold for your Penguin Robot?

He will remain in the project collection as one of the first Penguin prototypes. ●

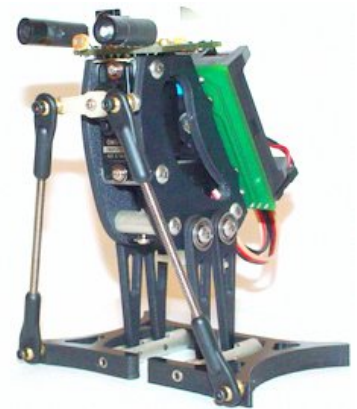

On April 30, 2006, Eric Rodemeyer was busy milling Penguin Robot parts using his homebuilt milling machine and some guidelines provided by Ken Gracey at Parallax Inc .

“Everyone I have run across has had a positive comment. Many are interested in buying a prefab kit form of this Penguin.

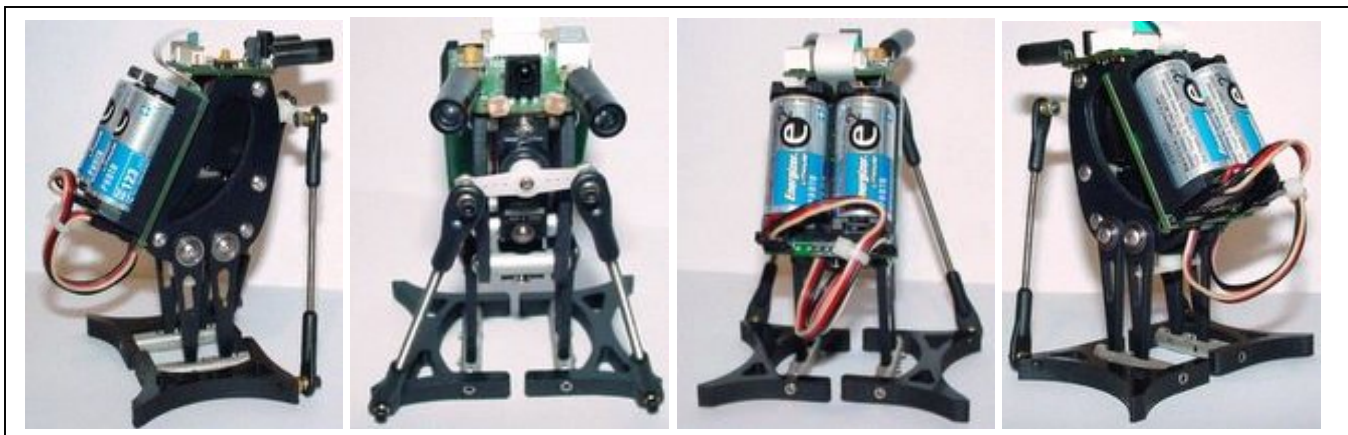

Eric Rodemeyer built his own Penguin Robot version, and even created his own milling machine from commonly available parts and materials. The photos above show the great success he achieved. Eric has since added small bearings at the hips. Note the sturdy front linkages and early Parallax prototype Penguin Robot green motherboard with the IR transmitters to the outside and the CdS light detectors on the inside. Current Penguin boards, at the time of this publication, are black and have this configuration reversed. The typical battery holder for Penguin is from Keystone, size “N” for CR123 batteries.



Pocket Penguin – Cute, Functional and Fits a Pocket!

Hack your way to cuteness



Build your own cute Pocket Penguin with a rubber band. Fold the main board over on top of the speaker. The mechanical chassis is removed.

Show off this tiny robot!

Most people will think Pocket Penguin, a stripped down hack to the full Penguin Robot, is the cat's pjamas! This is the smallest configuration of Penguin using the two boards and an optional (PING))) ultrasonic sensor. Pocket Penguin was born for several reasons:
*It functions without bulky

mechanics * It's shirt pocket portable * It consumes less battery power * It works with IR, optical light, sound, music, display, compass, AI and Virtual Reality! Building a Pocket Penguin is a piece of cake! Just remove the two boards and connect together as shown with a single rubber band. The only adjustment is to mount the

top board at a slight angle so the peizo speaker will have good volume. Think of some application ideas? How about a pocket Jukebox, night vision ranger, event timer, Penguinese talker, morse code sender, theremin musical instrument, digital compass pathfinder, and code within the new dimension of Virtual Reality! ●



Kit Tips for Building Penguin Robots

We're adding to Penguin Robot's Assembly Manual, and providing some useful tips and techniques to streamline the process.

One of the most confronting issues is the proper placement of the servo cables.

Too far one way, the cable will end up pinched. Too far the other way, and it will end up mixed with another cable.

Unplug both cables on a completed Penguin Robot to see what we're talking about. It's difficult to know which

is tilt and which is stride as they look identical. You really don't want to mix up tilt and stride as their ranges and calibrations are different. That could result in an out-of-range condition, something to avoid.

The solution (see photo) is to tuck the tilt servo cable into the side, along the chassis so that when it exits the assembled frame from under the battery holder board, it will be nearest J2. Then plug it into J2. The cable closest to J2 will be the tilt servo cable. ●

Routing Servo Cables

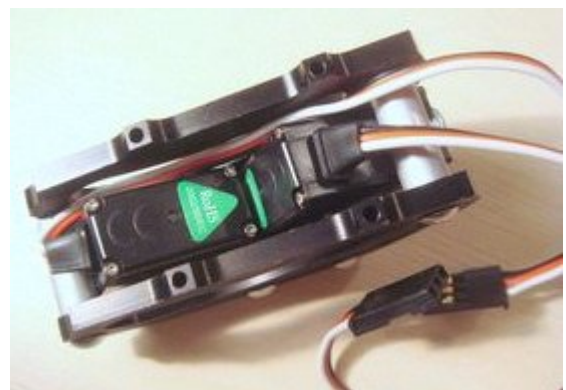

Photo showing the correct tucked routing of the tilt servo cable, which will exit the bottom side of the robot chassis closest to the tilt connector J2 where it will plug in. Looking at the back of Penguin, the color code for the each connector is black, red, white, as seen from left to right.



A Guide to Humanoido's Penguin Robot Code

PART 1: Years in the making, this is the largest growing collection of PBASIC programs giving Penguin Robot many new talents.

Here you'll find a robot operating system, soccer, happy dancing, running, music, sound effects, vision, remote control, weightlifting, utilities, and many Virtual Reality programs! Note: the program to calibrate tilt and stride is marked in red. •

275 Penguin Programs

Lucky 6 Display Flurry

1 penguin_display_demo.bpx
<http://forums.parallax.com/forums/default.aspx?f=10&m=239529>

7 penguin_2digit_display.bpx
<http://forums.parallax.com/forums/default.aspx?f=10&m=218325>
 8 penguin_3digit_display.bpx
<http://forums.parallax.com/forums/default.aspx?f=10&m=226470>
 9 penguin_1923_keyer.bpx
<http://forums.parallax.com/forums/default.aspx?f=10&m=230343>
 10 penguin_auto_weightlift.bpx
<http://forums.parallax.com/forums/default.aspx?f=10&m=241951>

11 **penguin_automatic_servo_calibrator.bpx**
<http://forums.parallax.com/forums/default.aspx?f=10&m=211927>
 12 penguin_basic_counter.bpx
<http://forums.parallax.com/forums/default.aspx?f=10&m=233091>
 13 penguin_body_switch.bpx
<http://forums.parallax.com/forums/default.aspx?f=10&m=226480>
 14 penguin_brain_timer.bpx
<http://forums.parallax.com/forums/default.aspx?f=10&m=227892>
 15 penguin_calibration_companion.bpx
<http://forums.parallax.com/forums/default.aspx?f=10&m=212070>
 16 penguin_code_tapper.bpx
<http://forums.parallax.com/forums/default.aspx?f=10&m=239461>
 17 penguin_continuous_counter.bpx
<http://forums.parallax.com/forums/default.aspx?f=10&m=226744>
 18 penguin_counting_eye.bpx
<http://forums.parallax.com/forums/default.aspx?f=10&m=239878>
 19 penguin_display_graphics.bpx
<http://forums.parallax.com/forums/default.aspx?f=10&m=219849>
 20 penguin_gone_wild.bpx
<http://forums.parallax.com/forums/default.aspx?f=10&m=226747>

21 penguin_happy_feet.bpx
<http://forums.parallax.com/forums/default.aspx?f=10&m=211710>
 22 penguin_jukebox.bpx
<http://forums.parallax.com/forums/default.aspx?f=10&m=231529>
 23 penguin_ktv_karaoke.bpx
<http://forums.parallax.com/forums/default.aspx?f=10&m=219558>
 24 penguin_line_dance_tv6.bpx
<http://forums.parallax.com/forums/default.aspx?f=10&m=215143>
 25 penguin_memory_master.bpx
<http://forums.parallax.com/forums/default.aspx?f=10&m=236463>
 26 penguin_memory_reader.bpx

<http://forums.parallax.com/forums/default.aspx?f=10&m=232740>
 27 penguin_modern_keyer.bpx
<http://forums.parallax.com/forums/default.aspx?f=10&m=230480>
 28 penguin_morse_messaging.bpx
<http://forums.parallax.com/forums/default.aspx?f=10&m=229666>
 29 penguin_motion_snapshot.bpx
<http://forums.parallax.com/forums/default.aspx?f=10&m=233855>
 30 penguin_motion_startup.bpx
<http://forums.parallax.com/forums/default.aspx?f=10&m=236470>

31 penguin_old_age_walk.bpx
<http://forums.parallax.com/forums/default.aspx?f=10&m=234202>
 32 penguin_os.bpx
<http://forums.parallax.com/forums/default.aspx?f=10&m=239878>
 33 penguin_penguinese.bs2
<http://forums.parallax.com/forums/default.aspx?f=10&m=240344>
 34 penguin_ping_ultravision.bpx
<http://forums.parallax.com/forums/default.aspx?f=10&m=236947>
 35 penguin_plotter.bpx
<http://forums.parallax.com/forums/default.aspx?f=10&m=239646>
 36 penguin_powerful_eye.bpx
<http://forums.parallax.com/forums/default.aspx?f=10&m=237355>
 37 penguin_radio.bpx
<http://forums.parallax.com/forums/default.aspx?f=10&m=240363>
 38 penguin_remote_companion.bpx
<http://forums.parallax.com/forums/default.aspx?f=10&m=217880>
 39 penguin_remote_controller.bpx
<http://forums.parallax.com/forums/default.aspx?f=10&m=217315>
 40 penguin_rocket_launcher.bpx
<http://forums.parallax.com/forums/default.aspx?f=10&m=232330>

41 penguin_rollersk8_dance.bpx
<http://forums.parallax.com/forums/default.aspx?f=10&m=219266>
 42 penguin_round_number.bpx
<http://forums.parallax.com/forums/default.aspx?f=10&m=234617>
 43 penguin_run.bpx
<http://forums.parallax.com/forums/default.aspx?f=10&m=238757>
 44 penguin_scout_compass.bpx
<http://forums.parallax.com/forums/default.aspx?f=10&m=225665>
 45 penguin_scouting_feet.bpx
<http://forums.parallax.com/forums/default.aspx?f=10&m=225608>
 46 penguin_screen_compass.bpx
<http://forums.parallax.com/forums/default.aspx?f=10&m=234623>
 47 penguin_shag_walker.bpx
<http://forums.parallax.com/forums/default.aspx?f=10&m=218663>
 47 penguin_sleep_machine.bpx
<http://forums.parallax.com/forums/default.aspx?f=10&m=219547>
 49 penguin_small_walker.bpx
<http://forums.parallax.com/forums/default.aspx?f=10&m=239223>
 50 penguin_sound_compass.bpx
<http://forums.parallax.com/forums/default.aspx?f=10&m=225672>

51 penguin_spaced_2001.bpx
<http://forums.parallax.com/forums/default.aspx?f=10&m=236473>
 52 penguin_startup_instructions.bpx
<http://forums.parallax.com/forums/default.aspx?f=10&m=231520>
 53 penguin_strongman.bpx
<http://forums.parallax.com/forums/default.aspx?f=10&m=241965>
 54 penguin_sumo.bpx
<http://forums.parallax.com/forums/default.aspx?f=10&m=239521>
 55 penguin_theremin.bpx
<http://forums.parallax.com/forums/default.aspx?f=10&m=227435>
 56 penguin_tic_tac_toe.bsp
<http://forums.parallax.com/forums/default.aspx?f=10&m=231094>
 57 penguin_tiltstride_reader.bpx
<http://forums.parallax.com/forums/default.aspx?f=10&m=232731>
 58 penguin_tiny_timer.bpx
<http://forums.parallax.com/forums/default.aspx?f=10&m=218083>
 59 penguin_transformer_cricket.bpx
<http://forums.parallax.com/forums/default.aspx?f=10&m=225617>

60 penguin_transformer_frog.bpx
<http://forums.parallax.com/forums/default.aspx?f=10&m=237745>
 61 penguin_vibrato_machine.bpx
<http://forums.parallax.com/forums/default.aspx?f=10&m=231524>
 62 penguin_virtual_keyboard.bpx
<http://forums.parallax.com/forums/default.aspx?f=10&m=229249>
 63 penguin_virtual_touchpad.bpx
<http://forums.parallax.com/forums/default.aspx?f=10&m=228378>
 64 penguin_virtual_volume_amp.bpx
<http://forums.parallax.com/forums/default.aspx?f=10&m=239876>
 65 penguin_wireless_soccer.bpx
<http://forums.parallax.com/forums/default.aspx?f=10&m=216568>

66-275 virtual sound chip programs (210 programs)
<http://forums.parallax.com/forums/default.aspx?f=10&m=238313>

16 Posted Bonus Code

1) penguin_freqout.bpx
<http://forums.parallax.com/forums/default.aspx?f=10&m=262598>
 2) penguin_ir_analyzer.bpx
<http://forums.parallax.com/forums/default.aspx?f=10&m=264362>
 3) penguin_jam.bpx
<http://forums.parallax.com/forums/default.aspx?f=10&m=264510>
 4) penguin_jammer.bpx
<http://forums.parallax.com/forums/default.aspx?f=10&m=264184>
 5) penguin_one_number.bpx
<http://forums.parallax.com/forums/default.aspx?f=10&m=264515>
 6) penguin_pulsout.bpx
<http://forums.parallax.com/forums/default.aspx?f=10&m=262602>
 7) penguin_realtime_dataplotter.bpx
<http://forums.parallax.com/forums/default.aspx?f=10&m=261514>
 8) penguin_serout.bpx
<http://forums.parallax.com/forums/default.aspx?f=10&m=262609>
 9) penguin_toggle.bpx
<http://forums.parallax.com/forums/default.aspx?f=10&m=262603>
 10) penguin_virtual_soundchip.bpx
<http://forums.parallax.com/forums/default.aspx?f=10&m=262595>
 11) penguin_retina_display.bpx
<http://forums.parallax.com/forums/default.aspx?f=10&m=268181>
 13) penguin_eye_skin.bpx
<http://forums.parallax.com/forums/default.aspx?f=10&m=268368>
 14) penguin_sound_determinator
<http://forums.parallax.com/forums/default.aspx?f=10&m=269288>
 14) penguin_seeing_eye_dog
<http://forums.parallax.com/forums/default.aspx?f=10&m=269881>
 15) penguin_display_dimmer
<http://forums.parallax.com/forums/default.aspx?f=10&m=274992>
 15) penguin_visual_alarm
<http://forums.parallax.com/forums/default.aspx?f=10&m=275740>
 16) penguin_tiny_mce
<http://forums.parallax.com/forums/default.aspx?f=10&m=275738>

5 Code Related Movies

1) Happy Dance
http://www.youtube.com/watch?v=9owS1Xhh_Mo
 2) Weightlifter
<http://www.youtube.com/watch?v=GQwxJN6f-oQ>
 3) Robot "Android" Dance
<http://www.youtube.com/watch?v=LpH3ZsNwBn8>
 4) Roller Skate Dance
http://www.youtube.com/watch?v=G_H3teQdxxw
 5) Soccer
<http://www.youtube.com/watch?v=5Duxpxu4Bhs>



Penguin Tech Journal

Publishing and
Distribution



United States
Hong Kong
Mainland China
Taiwan
Singapore
Thailand
Netherlands
Germany
U.K.
Sweden
Canada

For others countries,
inquiries are
welcome.

E-mail:
penguin.robot@yahoo.com

Contributing authors are
welcome. Ask for Writer
Guidelines via email.

Penguin Tech journal is a
concept by humanoide.
Penguin Robot Society is a
non profit organization
comprised of Penguin Robot
enthusiasts. 08.08.08

We're almost on the
Web!

See us in the future

Talk About Penguin Robot

Penguin Robot is the latest dream machine imagined and built by the remarkable mind of Ken Gracey at Parallax Inc. Parallax is a leading manufacturer and provider of tiny microprocessors (Basic Stamps), robots, sensors and parts: for schools, educators, hobbyists, and professionals. Based on a 2-servo tilt/stride

walking design by David Buckley, Penguin Robot is a remarkable futuristic desktop biped robot. Evolved from Toddler Robot, a previous robot in the Parallax' robot family tree, Penguin has many new robotic talents achieved by built in gadgets and remarkable add-on software. •



About Penguin Robot Society

Penguin Robot Society (PRS) was born from an idea by humanoide and immediately followed by a handful of die-hard Penguin Robot enthusiasts, even before Parallax decided that Penguin Robot would be a full scale production robot. Initial members had either received test bed models or sample units, decided to

build their own DIY Penguins, or entered a wish list. For years, enthusiasts followed the Parallax Forum postings that detailed the progress of Penguin Robot. Many that were inspired had the grace and support of Penguin Designer Ken Gracey, who was known to help out with Penguin diagrams, photos, support,

guidance, direction, and parts from time to time. Membership is free and now open to the Society. To join the the Penguin Robot Society, send an email (address below) describing your Penguin interests, an idea or two, what you're working on, or basically tell us anything about your Penguin Robot thoughts. •

Some Useful Links and References...

Penguin Robot Society penguin.robot@yahoo.com
Parallax Inc. <http://www.parallax.com/>
Parallax Forums <http://forums.parallax.com/forums/>
Robot Magazine <http://www.botmag.com/>
David Buckley <http://www.davidbuckley.net/DB/inspired/KenGracey/KenGracey.htm#MiniToddler/>

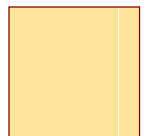

FULL NAME
STREET ADDRESS
CITY, ST 99999