

FEATURES

- Display Diagonal: 8.4"
- Display Format: 640 × 480
(1 Pixel = R + G + B Dots)
- Overall Dimensions:
243.5 (W) × 180 (H) × 12 (D) mm
(Excludes Backlight Cables)
- Active Area: 170.88 (W) × 129.6 (H)
- Dot Pitch: 0.267 (W) × 0.27 (H) mm
- Viewing Angle: 6 O'Clock
- Pixel Configuration: R, G, B Vertical Stripe
- Display Mode: Normally White

DESCRIPTION

The SHARP LQ9D011 Color TFT-LCD module is an active matrix Liquid Crystal Display (LCD) incorporating amorphous silicon Thin Film Transistor (TFT). The module is composed of a color TFT-LCD panel, driver ICs, control circuit, and a power supply circuit. Graphics and text can be displayed on a 640 × 3 × 480 dot panel in 512 colors by supplying a 9-bit data signal, four kinds of timing signals, +5 VDC, and supply voltage for the backlight. Optimum viewing angle is at the 6 o'clock direction.

400-line and 350-line modes, in addition to 480-line mode, can also be applied to this module.

NOTE: A backlight-driving DC/AC inverter is not built into this module.

MECHANICAL SPECIFICATIONS

PARAMETER	SPECIFICATIONS	UNIT	NOTE
Outline Dimensions	242.5 (W) × 179.4 (H) × 8.2 (D)	mm	1
Screen Size (Diagonal)	8.4 (Diagonal)	cm	
Active Area	170.9 (H) × 129.6 (V)	mm	–
Display Pixels	640 (H) × 480 (V) (1 pixel = R + G + B dots)	pixel	–
Pixel Pitch	0.267 (H) × 0.270 (V)	mm	–
Pixel Configuration	RGB Vertical Stripe	–	–
Display Mode	Normally White	–	–
Weight	570 ±20	g	–
Surface Treatment	Anti-Glare and Hard Coating 2 H	–	2

NOTES:

1. Excludes component height (9.0 mm maximum).
2. Incoming light side.

ABSOLUTE MAXIMUM RATINGS

SYMBOL	PARAMETER	CONDITION	RATINGS	UNIT	NOTE
V _I	Input Voltage	t _A = 25°C	–0.3 to V _{CC} +0.3	V	1
V _{CC}	+5 V Supply Voltage		–0.3 to +7	V	
T _{stg}	Storage Temperature	–	–25 to +60	°C	2
T _{opa}	Operating Temperature (Ambient)	–	0 to +50	°C	

NOTES:

1. CK, R0 to R2, G0 to G2, B0 to B2, Hsync, Vsync, ENAB.
2. Humidity: 95% RH maximum at t_A ≤ 40°C. Maximum wet-bulb temperature 39°C or less at t_A > 40°C. No condensation.

INPUT TERMINALS – TFT-LCD PANEL DRIVER

CN1 (Interface Signal)¹

PIN NUMBER	SYMBOL	FUNCTION	POLARITY	NOTE
1	CK	Clock Signal for Sampling Each Data Signal	–	
2	GND	–	–	
3	Hsync	Horizontal Sync Signal		2
4	Vsync	Vertical Sync Signal		2
5	R0	RED Data Signal (LSB)	Positive	
6	R1	RED Data Signal	Positive	
7	R2	RED Data Signal (MSB)	Positive	
8	GND	–	–	
9	G0	GREEN Data Signal (LSB)	Positive	
10	G1	GREEN Data Signal	Positive	
11	G2	GREEN Data Signal (MSB)	Positive	
12	GND	–	–	
13	B0	BLUE Data Signal (LSB)	Positive	
14	B1	BLUE Data Signal	Positive	
15	B2	BLUE Data Signal (MSB)	Positive	

NOTES:

- Connector used: DF13-15P-1.25H (Hirose Electric Co., Ltd.)
Mating connector: DF13-15S-1.25C (Hirose Electric Co., Ltd.)
- Polarity of the sync signals:

MODE	480 LINES	400 LINES	350 LINES
Hsync	Negative	Negative	Positive
Vsync	Negative	Positive	Negative

CN2 (Signal and Power Supply) ¹

PIN NUMBER	SYMBOL	FUNCTION	POLARITY
1	V _{CC}	+5 V Power Supply	–
2	V _{CC}	+5 V Power Supply	–
3	GND	–	–
4	GND	–	–
5	ENAB	Data Enable Signal (to settle the viewing area)	Positive
6	TST	This Shall be Electrically Opened During Operation	–

NOTES:

The shielding case is connected with signal GND.

- Connector used: DF13-6P-1. 25H (Hirose Electric Co., Ltd.)
Mating connector: DF13-6S-1.25C (Hirose Electric Co., Ltd.)

INPUT TERMINALS – BACKLIGHT ¹

PIN NUMBER	SYMBOL	FUNCTION
CNA, CNC (Color: Red)		
1	V _{HIGH}	Power Supply for Lamp (High voltage side)
2	NC	
CNB, CND (Color: White)		
1	NC	
2	V _{LOW}	Power Supply for Lamp (Low voltage side)

NOTES:

- Connector used: EHR-2 (JST)
Mating connector: S2B-EH (JST)
- Cable length : CNA and CNC 50 ±10 mm. CNB and CND 90 ±10 mm (refer to the Outline Dimensions diagram).

ELECTRICAL CHARACTERISTICS AND CURRENT DISSIPATION – TFT-LCD PANEL DRIVING ($t_A = 25^\circ\text{C}$)

SYMBOL	PARAMETER	CONDITION	MIN.	TYP.	MAX.	UNIT	NOTE
V_{CC}	+5 V Supply Voltage	–	+4.75	+5.0	+5.25	V	See Figure 1
I_{CC}	+5 V Current Dissipation	–	–	400	600	mA	1
V_{IL}	Input Voltage (Low) (excluding ENAB)	$V_{CC} = +5\text{ V}$	–	–	1.5	V	–
V_{ILS}	Input Voltage (Low) (ENAB)		–	–	0.8	V	
V_{IH}	Input Voltage (High)		+3.5	–	–	V	
V_{RP}	Permissive Input Ripple Voltage	V_{CC}	–	–	50	mVp-p	–
I_{OL}	Input Leakage Current	$V_I = 0\text{ V}$	–10	–	0	μA	–
I_{OU}		$V_I = V_{CC}$	0	–	+10	μA	–

NOTE:

1. Typical current situation is defined 8-color-bar pattern (at 480 line mode, $V_{CC} = 5\text{ V}$).

ELECTRICAL CHARACTERISTICS – BACKLIGHT ($t_A = 25^\circ\text{C}$)¹

SYMBOL	PARAMETER	CONDITION	MIN.	TYP.	MAX.	UNIT	NOTE
V_L	Lamp Voltage	Just for reference	–	400	–	V_{RMS}	–
I_L	Lamp Current	Just for reference	4.5	5.0	5.5	mARMS	–
P_L	Lamp Power Consumption	–	–	2.0	–	W	2
F_L	Frequency	–	20	–	60	kHz	3
V_S	Kick-Off Voltage	$t_A = 25^\circ\text{C}$	–	–	1000	V_{RMS}	–
		$t_A = 0^\circ\text{C}$	–	–	1200	V_{RMS}	–
T_L	Lamp Life Time	–	10000	–	–	Hour	4

NOTES:

1. The backlight system is an edge-lighting type (a couple of CCFTs). The characteristics of its single lamp are shown in the table above.
2. Calculated value for reference ($I_L \times V_L$).
3. Lamp frequency may produce interference with horizontal sync frequency, causing heat on the display. Therefore, make lamp frequency as different as possible from the ones of Horizontal sync and harmonics horizontal sync to avoid interference.
4. Brightness becomes 50% of the original brightness at standard conditions.

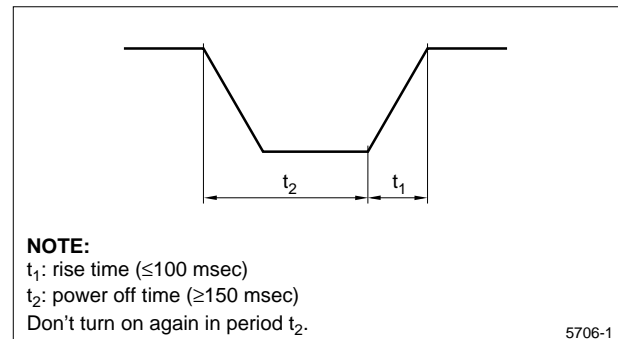

Figure 1. Power ON/OFF Period

TIMING CHARACTERISTICS OF INPUT SIGNALS ¹

SYMBOL	PARAMETER	MODE	MIN.	TYP.	MAX.	UNIT	
1/t _C	Clock Frequency	ALL	–	25.175	28.322	MHz	
t _{CH}	Clock High Time	ALL	5	–	–	ns	
t _{CL}	Clock Low Time	ALL	10	–	–	ns	
t _{DS}	Data Setup Time	ALL	5	–	–	ns	
t _{DH}	Data Hold Time	ALL	10	–	–	ns	
t _{ES}	Enable Signal Setup Time	ALL	5	–	–	ns	
t _H	Horizontal Sync Signal Cycle	ALL	30.58	31.78	35.75	μs	
		ALL	770	800	900	Clock	
t _{HP}	Horizontal Sync Signal Pulse Width	ALL	–	96	–	Clock	
t _V	Vertical Sync Signal Cycle	480	–	16.7	525	ms	Line
		400	–	14.3	449	ms	Line
		350	–	14.3	449	ms	Line
t _{VP}	Vertical Sync Signal Pulse Width	ALL	–	2	–	Line	
t _{HS}	Horizontal Signal Display Start	ALL	–	(144)	–	Clock	
t _{HD}	Horizontal Signal Display Period	ALL	–	640	–	Clock	
t _{VS}	Vertical Sync Signal Display Start	480	–	34	–	Line	
		400	–	34	–	Line	
		350	–	61	–	Line	
t _{VD}	Vertical Sync Signal Display Period	480	–	480	–	Line	
		400	–	400	–	Line	
		350	–	350	–	Line	
t _{VF}	Hsync-Vsync Phase Difference – Front	ALL	0	–	–	ns	
t _{VB}	Hsync-Vsync Phase Difference – Back	ALL	–10	–	–	ns	

NOTES:

1. Make sure that timing of the signals are above data (standard VGA) to ensure right display position and display quality.
2. Data enable signal should be Low longer than one clock in every horizontal period.
3. Input signal waveforms are shown in Figures 3a, 3b, and 3c.

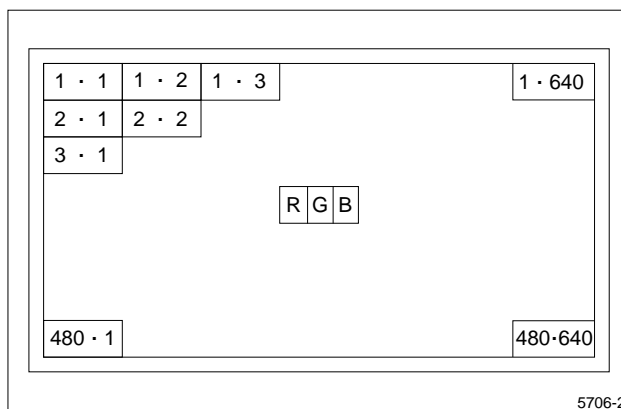
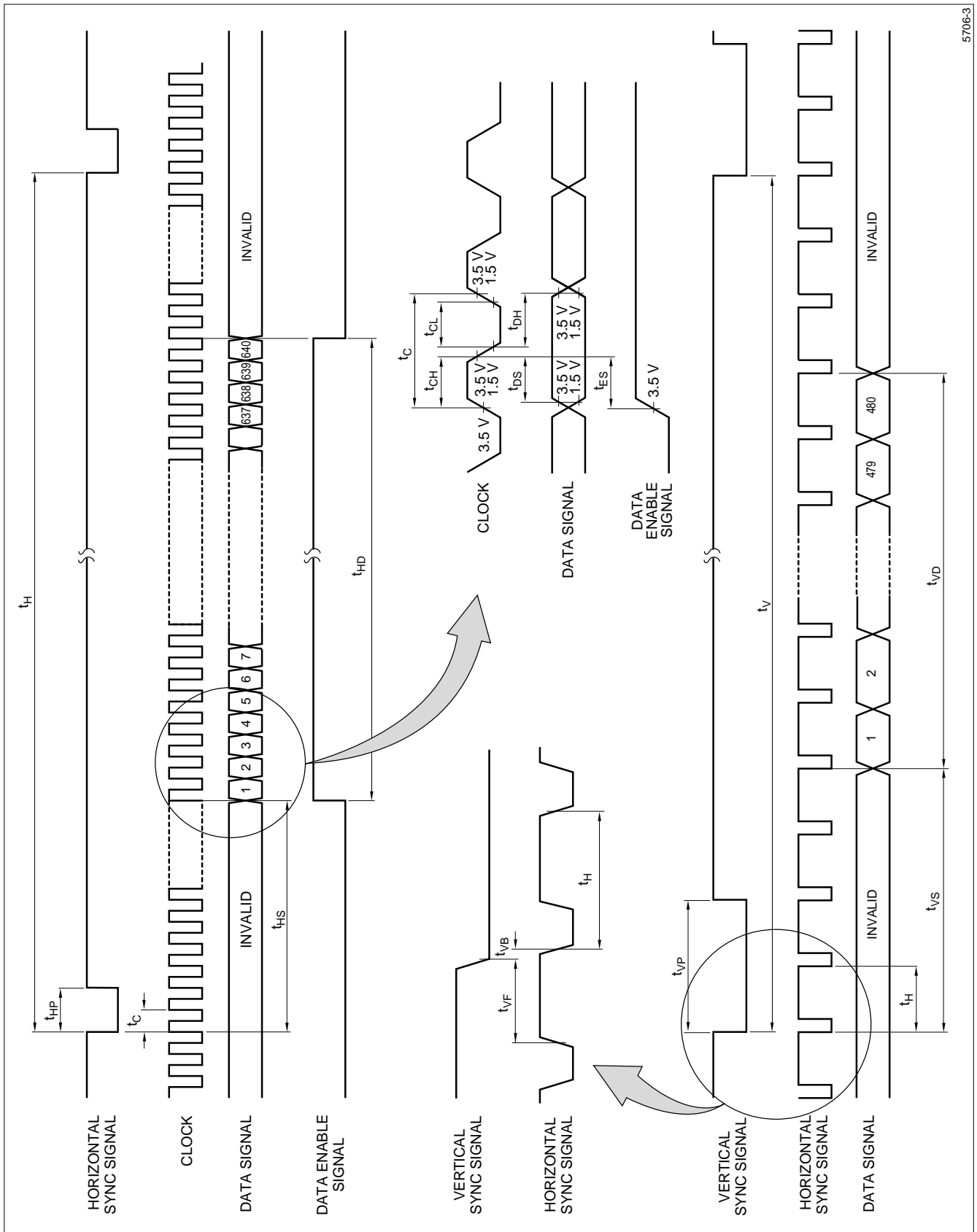
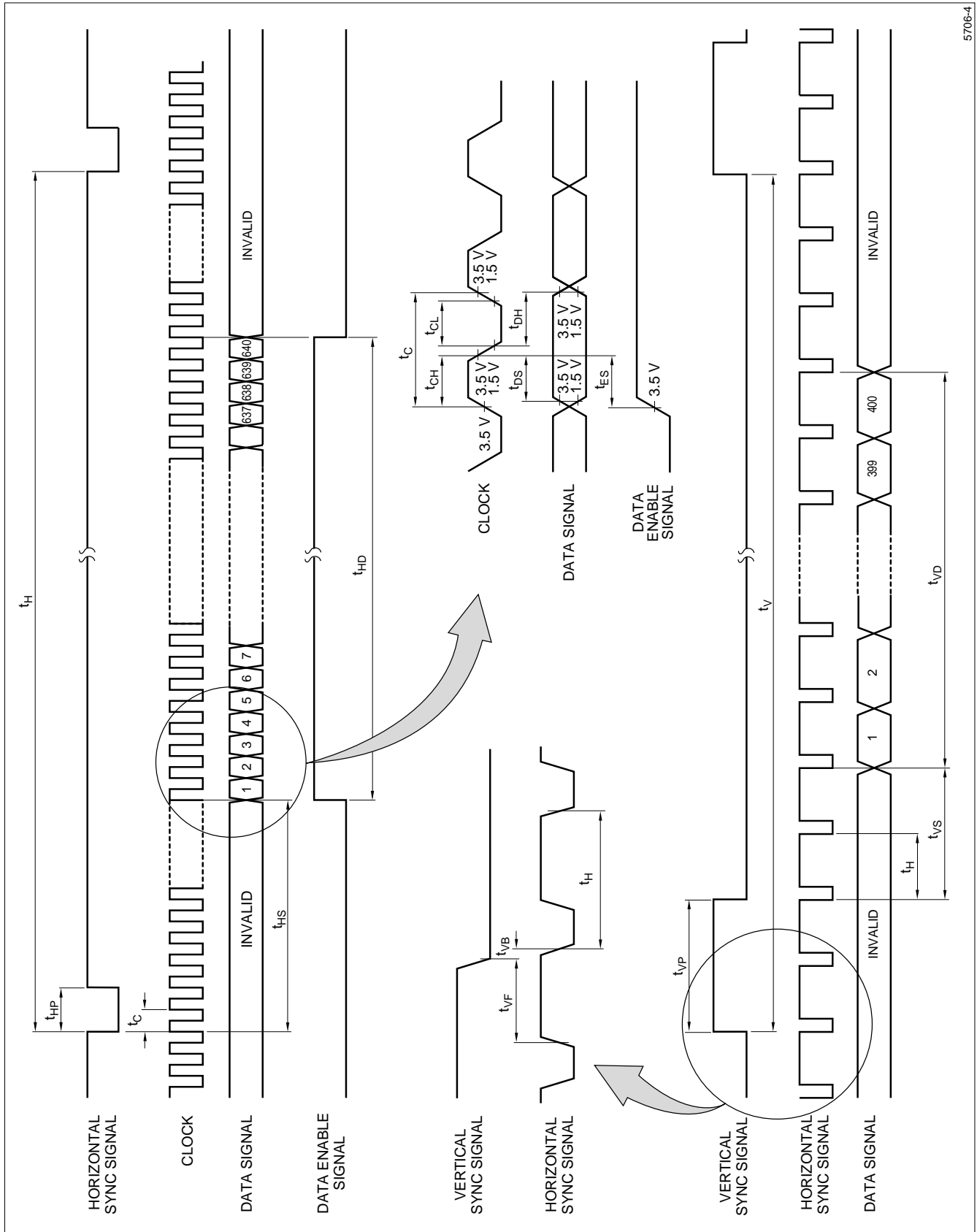

Figure 2. Input Signals and Display on Screen



5706-3

Figure 3a. Input Signal Waveform (480 Line Mode)



5706-4

Figure 3b. Input Signal Waveform (400 Line Mode)

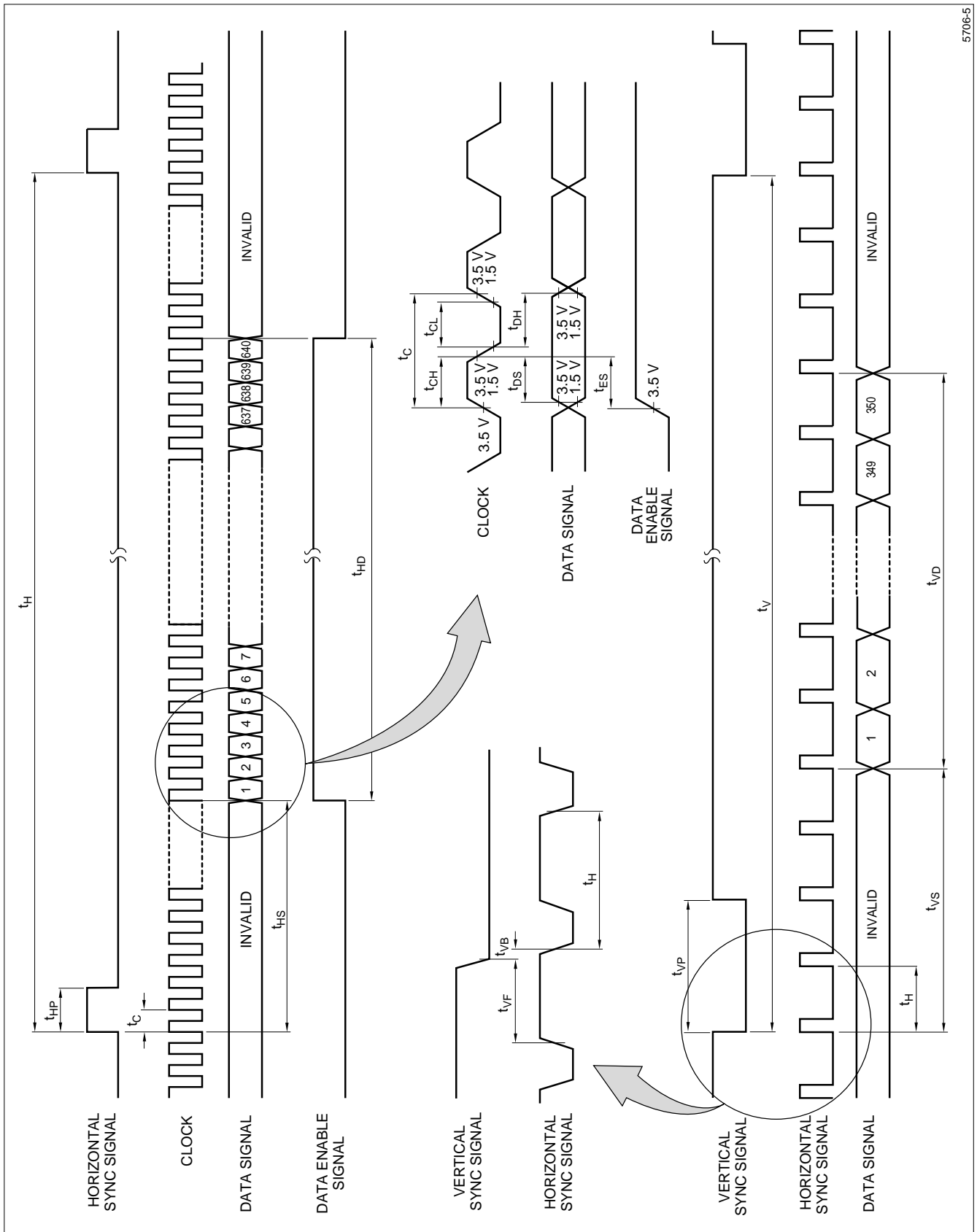

5706-5

Figure 3c. Input Signal Waveform (350 Line Mode)

INPUT SIGNALS, BASIC DISPLAY COLORS, AND GRAY SCALE OF EACH COLOR ¹

COLOR AND GRAY SCALE		DATA SIGNAL ²								
		R ₀	R ₁	R ₂	G ₀	G ₁	G ₂	B ₀	B ₁	B ₂
Basic Color	Black	0	0	0	0	0	0	0	0	0
	Blue	0	0	0	0	0	0	1	1	1
	Green	0	0	0	1	1	1	0	0	0
	Light Blue	0	0	0	1	1	1	1	1	1
	Red	1	1	1	0	0	0	0	0	0
	Purple	1	1	1	0	0	0	1	1	1
	Yellow	1	1	1	1	1	1	0	0	0
	White	1	1	1	1	1	1	1	1	1
Gray Scale of Red	Black	0	0	0	0	0	0	0	0	0
	↑	1	0	0	0	0	0	0	0	0
	Darker	0	1	0	0	0	0	0	0	0
	↑	1	1	0	0	0	0	0	0	0
	↓	0	0	1	0	0	0	0	0	0
	Brighter	1	0	1	0	0	0	0	0	0
	↓	0	1	1	0	0	0	0	0	0
	Red	1	1	1	0	0	0	0	0	0
Gray Scale of Green	Black	0	0	0	0	0	0	0	0	0
	↑	0	0	0	1	0	0	0	0	0
	Darker	0	0	0	0	1	0	0	0	0
	↑	0	0	0	1	1	0	0	0	0
	↓	0	0	0	0	0	1	0	0	0
	Brighter	0	0	0	1	0	1	0	0	0
	↓	0	0	0	0	1	1	0	0	0
	Green	0	0	0	1	1	1	0	0	0
Gray Scale of Blue	Black	0	0	0	0	0	0	0	0	0
	↑	0	0	0	0	0	0	1	0	0
	Darker	0	0	0	0	0	0	0	1	0
	↑	0	0	0	0	0	0	1	1	0
	↓	0	0	0	0	0	0	0	0	1
	Brighter	0	0	0	0	0	0	1	0	1
	↓	0	0	0	0	0	0	0	1	1
	Blue	0	0	0	0	0	0	1	1	1

NOTES:

- Each color is displayed in eight gray scales from 3-bit data signal input. According to the combination of the total 9-bit data, 512 colors are displayed.
- 0 = Low Level Voltage
1 = High Level Voltage

OPTICAL CHARACTERISTICS (t_A = 25°C, V_{CC} = +5 V) ¹

SYMBOL	PARAMETER	CONDITION	MIN.	TYP.	MAX.	UNIT	NOTE
θ _{21,22}	Horizontal Viewing Angle Range	CR > 10	45	–	–	degrees	2, 5
θ ₁₁	Vertical Viewing Angle Range		10	–	–		
θ ₁₂			30	–	–		
CR	Contrast Ratio	Optimum Viewing Angle	60	–	–	–	3, 5
t _R	Response Time – Rise	θ = 0°	–	30	–	ms	4, 5
t _D	Response Time – Decay		–	50	–	ms	
x	Chromaticity of White		–	0.316	–	–	5
y			–	0.320	–	–	
Y _L	Luminance of White		50	70	–	nt	
δ _w	White Uniformity	–	–	1.25	–	6	

NOTES:

1. The measurement shall be executed 15-20 minutes after the module has been lit at the proper rating. The optical characteristics shall be measured in a dark room or equivalent state with the method shown in Figure 4.
2. Figure 5 shows the definitions of the viewing angle range.
3. The Contrast Ratio is defined as follows: Contrast Ratio = $\frac{\text{Luminance(brightness) with all pixels white}}{\text{Luminance(brightness) with all pixels black}}$
4. The Response Time is measured as shown in Figure 6 by switching the input signals for 'black' ON and OFF.
5. Measurements shall be taken at the center of the screen.
6. White Uniformity is defined as the following with five measurements (A-E) (Refer to Figure 7): $\frac{\text{Maximum Luminance(brightness)}}{\text{Minimum Luminance(brightness)}}$

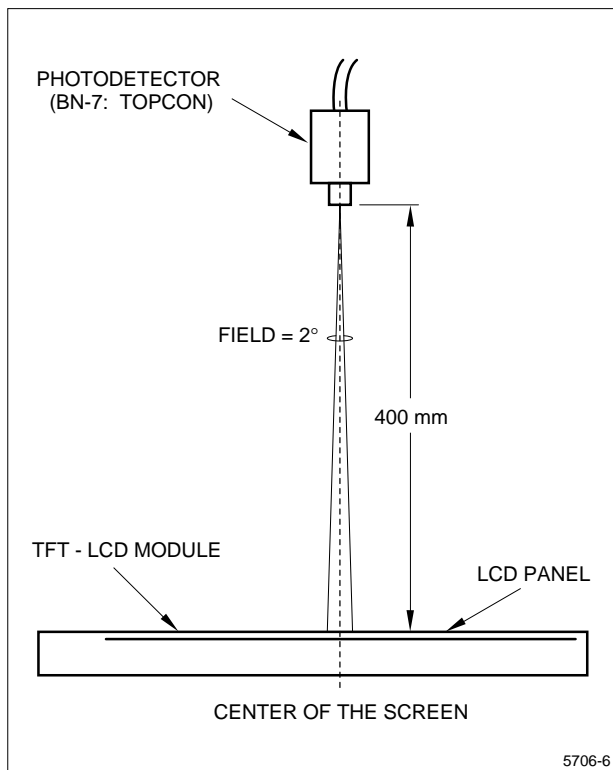

Figure 4. Optical Characteristics Measurement Method

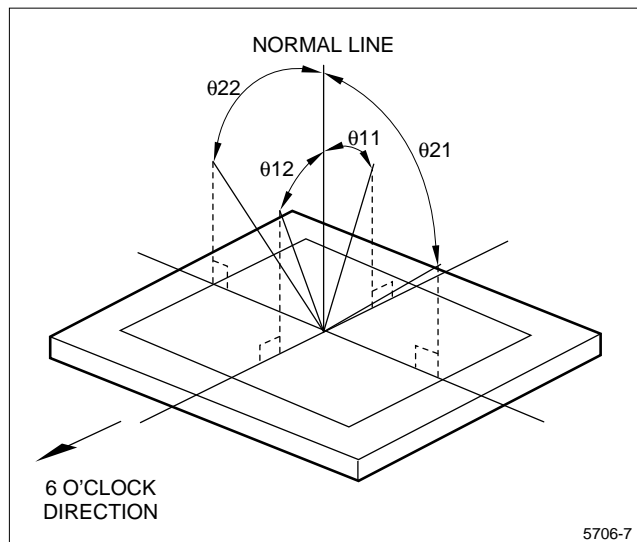

Figure 5. Definition of Viewing Angle

DISPLAY QUALITY

The display quality of the color TFT-LCD module shall be in compliance with the Delivery Inspection Standard.

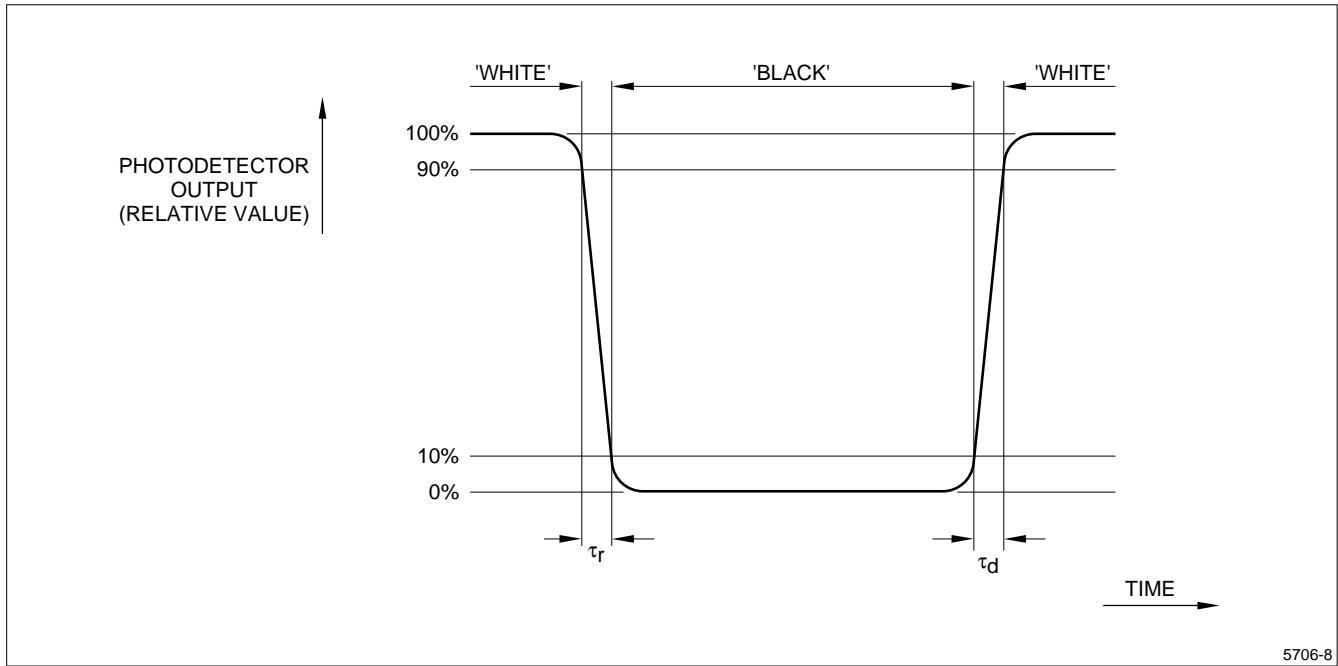

Figure 6. Definition of Response Time

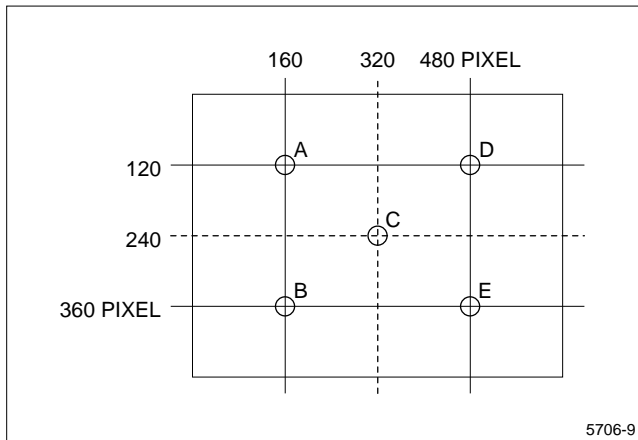

Figure 7. Definition of White Uniformity

- When the panel surface is soiled, wipe it with absorbent cotton or other soft cloth.
- Since the module uses glass, it may break or crack if dropped or bumped on a hard surface. Handle with care.
- Since CMOS LSI is used in this module, avoid static electric problems by grounding yourself before handling the module.
- Adjusting volumes have been optimally set before shipment, so do not change any adjusted values. If adjusted values are changed, the specifications described here may not be satisfied.
- Disassembling the module can cause permanent damage and should be strictly avoided.
- Observe all other precautionary requirements in handling components.

HANDLING PRECAUTIONS

- Be sure to insert the cable into the connector or take it out of the connector after turning off the power supply on the set side.
- Power ON/OFF sequential timing – To prevent the latch-up of the circuit in the module, keep the sequential timing between input signals and supply voltages as shown in Figure 8.
- When installing the module, be sure to fix the module on the same plane, taking care not to warp or twist the module.
- Handle the front polarizer carefully since it scratches easily.
- Wipe off water drops immediately. Long contact with water may cause discoloration or spots.

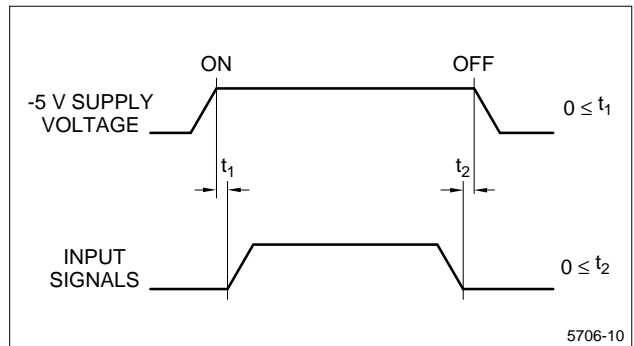

Figure 8. Power ON/OFF Sequency

PACKING SPECIFICATIONS

Refer to the Packing Form shown in Figure 10.

- Piling number of cartons: 5 (MAX)
- Package quantity in one carton: 10 (MAX)
- Carton size: 420 (W) × 355 (H) × 300 (D)
- Total weight of one carton filled with full modules: 8,500 g

RESULT EVALUATION CRITERIA

Under the display quality test conditions with normal operation state, there shall be no change which may affect practical display functions.

OTHER INFORMATION

If any problem should arise from this specification, the supplier and user should work out a mutually acceptable solution.

RELIABILITY TEST ITEMS

NUMBER	TEST ITEM	CONDITIONS
1	High Temperature Storage Test	$t_A = 60^\circ\text{C}$, 240 H
2	Low Temperature Storage Test	$t_A = -25^\circ\text{C}$, 240 H
3	High Temperature and High Humidity Operation Test	$t_A = 40^\circ\text{C}$, 95% RH, 240 H (No condensation)
4	High Temperature Operation Test	$t_A = 50^\circ\text{C}$, 240 H (The panel temperature must be less than 60°C)
5	Low temperature Operation Test	$t_A = 0^\circ\text{C}$, 240H
6	Vibration Test (Non-Operating)	Frequency: 10 to 57 Hz/Vibration width (one side): 0.075 mm, 58 to 500 Hz/Gravity: 1 G Sweep Time: 11 minutes Test Period: 3 hours in total (1 hour for each direction of X, Y, Z)
7	Shock Test (Non-Operating)	Maximum Gravity: 50 G Pulse Width: 11 ms, sine wave Direction: $\pm X$, $\pm Y$, $\pm Z$, once for each direction

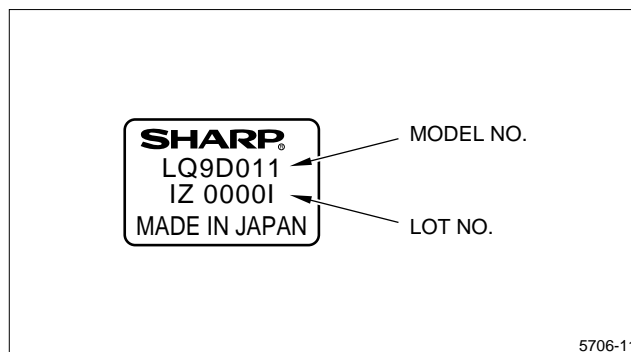

Figure 9. Lot Number Label

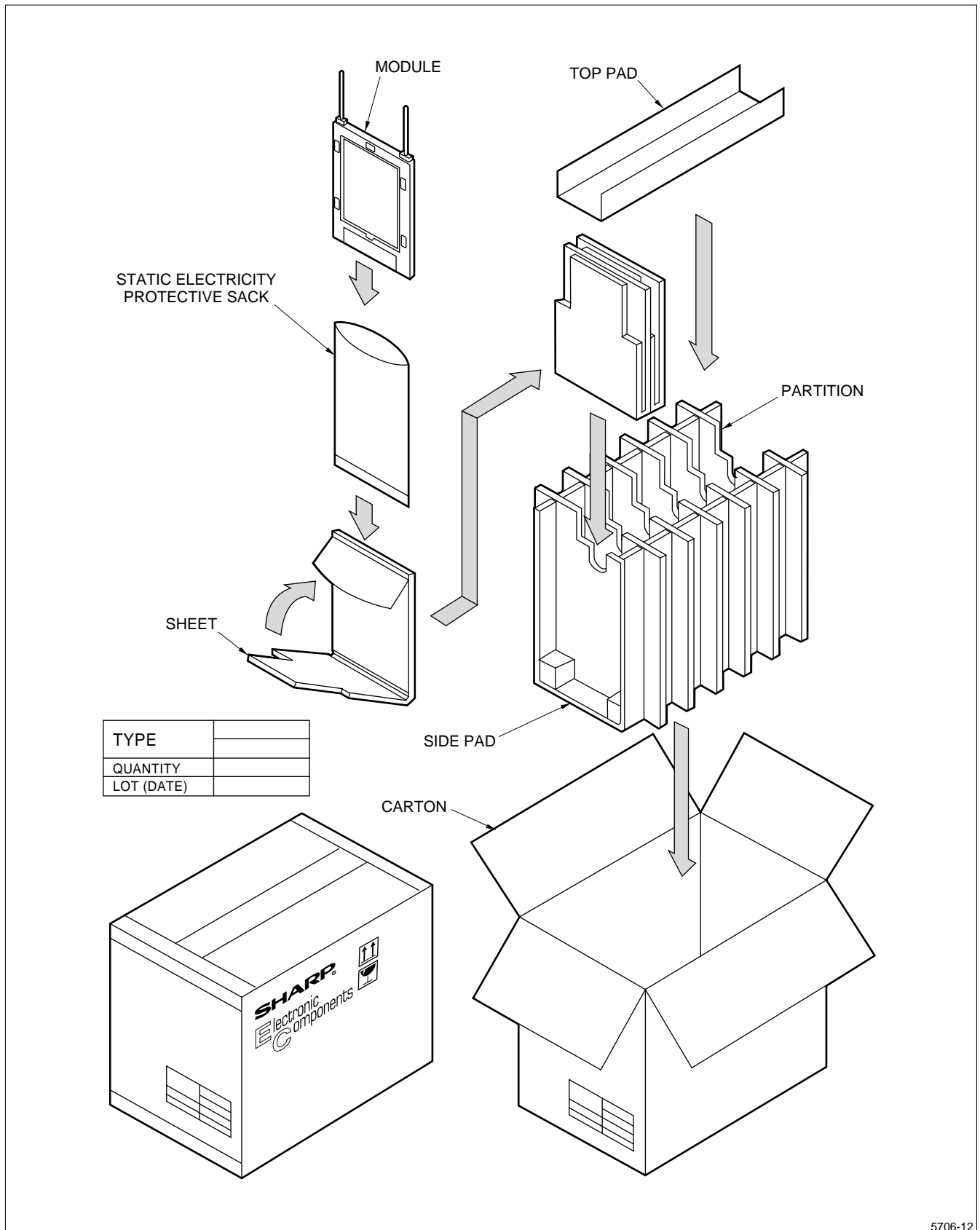

Figure 10. Packing Form

