



USB Peripheral/Host Controller with SPI Interface

MAX3421E

General Description

The MAX3421E USB peripheral/host controller contains the digital logic and analog circuitry necessary to implement a full-speed USB peripheral or a full-/low-speed host compliant to USB specification rev 2.0. A built-in transceiver features $\pm 15\text{kV}$ ESD protection and programmable USB connect and disconnect. An internal serial interface engine (SIE) handles low-level USB protocol details such as error checking and bus retries. The MAX3421E operates using a register set accessed by an SPI™ interface that operates up to 26MHz. Any SPI master (microprocessor, ASIC, DSP, etc.) can add USB peripheral or host functionality using the simple 3- or 4-wire SPI interface.

The MAX3421E makes the vast collection of USB peripherals available to any microprocessor, ASIC, or DSP when it operates as a USB host. For point-to-point solutions, for example, a USB keyboard or mouse interfaced to an embedded system, the firmware that operates the MAX3421E can be simple since only a targeted device is supported.

Internal level translators allow the SPI interface to run at a system voltage between 1.4V and 3.6V. USB-timed operations are done inside the MAX3421E with interrupts provided at completion so an SPI master does not need timers to meet USB timing requirements. The MAX3421E includes eight general-purpose inputs and outputs so any microprocessor that uses I/O pins to implement the SPI interface can reclaim the I/O pins and gain additional ones.

The MAX3421E operates over the extended -40°C to $+85^{\circ}\text{C}$ temperature range and is available in a 32-pin TQFP package (5mm x 5mm) and a 32-pin TQFN package (5mm x 5mm).

Applications

Embedded Systems	Desktop Routers
Medical Devices	PLCs
Microprocessors and DSPs	Set-Top Boxes
Custom USB Devices	PDA's
Cameras	MP3 Players
	Instrumentation

Features

- ◆ Microprocessor-Independent USB Solution
- ◆ Software Compatible with the MAX3420E USB Peripheral Controller with SPI Interface
- ◆ Complies with USB Specification Revision 2.0 (Full-Speed 12Mbps Peripheral, Full-/Low-Speed 12Mbps/1.5Mbps Host)
- ◆ Integrated USB Transceiver
- ◆ Firmware/Hardware Control of an Internal D+ Pullup Resistor (Peripheral Mode) and D+/D- Pulldown Resistors (Host Mode)
- ◆ Programmable 3- or 4-Wire, 26MHz SPI Interface
- ◆ Level Translators and V_L Input Allow Independent System Interface Voltage
- ◆ Internal Comparator Detects V_{BUS} for Self-Powered Peripheral Applications
- ◆ ESD Protection on D+, D-, and VBCOMP
- ◆ Interrupt Output Pin (Level- or Programmable-Edge) Allows Polled or Interrupt-Driven SPI Interface
- ◆ Eight General-Purpose Inputs and Eight General-Purpose Outputs
- ◆ Interrupt Signal for General-Purpose Input Pins, Programmable Edge Polarity
- ◆ Intelligent USB SIE
- ◆ Automatically Handles USB Flow Control and Double Buffering
- ◆ Handles Low-Level USB Signaling Details
- ◆ Contains Timers for USB Time-Sensitive Operations so SPI Master Does Not Need to Time Events
- ◆ Space-Saving Lead-Free TQFP and TQFN Packages (5mm x 5mm)

Ordering Information

PART	TEMP RANGE	PIN-PACKAGE	PKG CODE
MAX3421EEHJ+	-40°C to $+85^{\circ}\text{C}$	32 TQFP	H32-1
MAX3421EETG+*	-40°C to $+85^{\circ}\text{C}$	32 TQFN-EP**	T3255-4

*Future product—contact factory for availability.

**EP = Exposed paddle, connected to ground.

SPI is a trademark of Motorola, Inc.



USB Peripheral/Host Controller with SPI Interface

Features in Host Operation

- ◆ Eleven Registers (R21–R31) are Added to the MAX3420E Register Set to Control Host Operation
- ◆ Host Controller Operates at Full Speed or Low Speed
- ◆ FIFOS
 - SNDFIFO: Send FIFO, Double-Buffered 64-Byte
 - RCVFIFO: Receive FIFO, Double-Buffered 64-Byte
- ◆ Handles DATA0/DATA1 Toggle Generation and Checking
- ◆ Performs Error Checking for All Transfers
- ◆ Automatically Generates SOF (Full-Speed)/EOP (Low-Speed) at 1ms Intervals
- ◆ Automatically Synchronizes Host Transfers with Beginning of Frame (SOF/EOP)
- ◆ Reports Results of Host Requests
- ◆ Supports USB Hubs
- ◆ Supports ISOCHRONOUS Transfers
- ◆ Simple Programming
 - SIE Automatically Generates Periodic SOF (Full-Speed) or EOP (Low-Speed) Frame Markers
 - SPI Master Loads Data, Sets Function Address, Endpoint, and Transfer Type, and Initiates the Transfer
 - MAX3421E Responds with an Interrupt and Result Code Indicating Peripheral Response
 - Transfer Request Can be Loaded Any Time
 - SIE Synchronizes with Frame Markers
 - For Multipacket Transfers, the SIE Automatically Maintains and Checks the Data Toggles

Features in Peripheral Operation

- ◆ Built-In Endpoint FIFOS
 - EP0: CONTROL (64 bytes)
 - EP1: OUT, Bulk or Interrupt, 2 x 64 Bytes (Double-Buffered)
 - EP2: IN, Bulk or Interrupt, 2 x 64 Bytes (Double-Buffered)
 - EP3: IN, Bulk or Interrupt (64 Bytes)
- ◆ Double-Buffered Data Endpoints Increase Throughput by Allowing the SPI Master to Transfer Data Concurrent with USB Transfers
- ◆ SETUP Data Has its Own 8-Byte FIFO, Simplifying Firmware

Typical Application Circuits

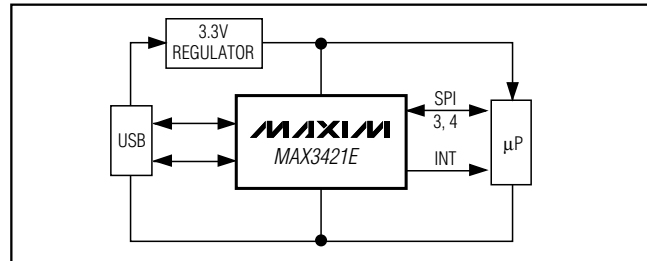

Figure 1. The MAX3421E Connects to Any Microprocessor Using 3 or 4 Interface Pins

The MAX3421E connects to any microprocessor (μ P) using 3 or 4 interface pins (Figure 1). On a simple microprocessor without SPI hardware, these can be bit-banged general-purpose I/O pins. Eight GPIN and eight GPOUT pins on the MAX3421E more than replace the μ P pins necessary to implement the interface. Although the MAX3421E SPI hardware includes separate data-in (MOSI, master-out, slave-in) and data-out (MISO, master-in, slave-out) pins, the SPI interface can also be configured for the MOSI pin to carry bidirectional data, saving an interface pin. This is referred to as half-duplex mode.

USB Peripheral/Host Controller with SPI Interface

Typical Application Circuits (continued)

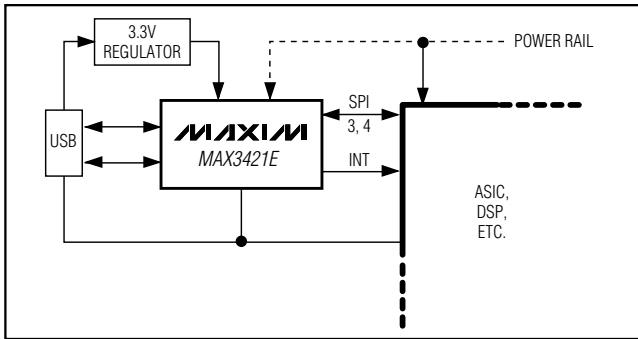

Figure 2. The MAX3421E Connected to a Large Chip

Two MAX3421E features make it easy to connect to large, fast chips such as ASICs and DSPs (Figure 2). First, the SPI interface can be clocked up to 26MHz. Second, the V_L pin and internal level translators allow running the system interface at a lower voltage than the 3.3V required for VCC.

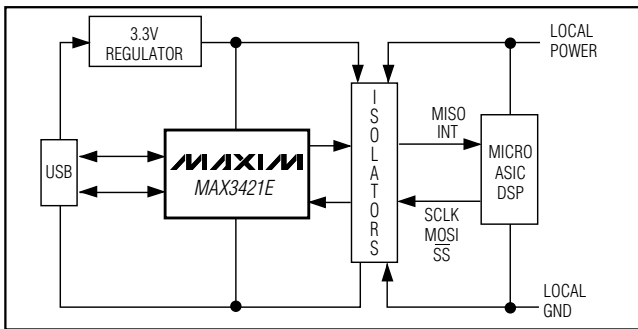

Figure 3. Optical Isolation of USB Using the MAX3421E

The MAX3421E provides an ideal method for electrically isolating a USB interface (Figure 3). USB employs flow control in which the MAX3421E automatically answers host requests with a NAK handshake, until the micro-processor completes its data-transfer operations over the SPI port. This means that the SPI interface can run at any frequency up to 26MHz. Therefore, the designer is free to choose the interface operating frequency and to make opto-isolator choices optimized for cost or performance.

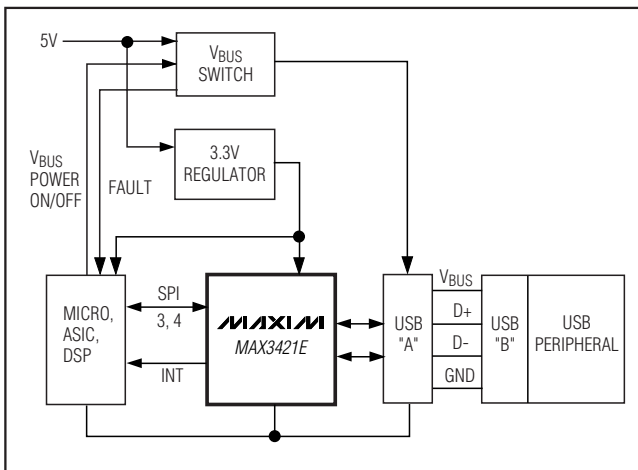

Figure 4. The MAX3421E in an Embedded Host Application

Figure 4 shows a block diagram for a system in which the MAX3421E operates as a USB host. A USB host supplies 5V power to the VBUS pin of the USB "A" connector to power USB peripherals. A system that provides power to an external peripheral should use protection circuitry on the power pin to prevent an external overcurrent situation from damaging the system. A VBUS switch, such as the MAX4789, provides power control plus two additional features: it limits the current delivered to the peripheral (for example to 200mA), and it indicates a fault (overcurrent) condition to the SPI controller. Maxim offers a variety of VBUS switches with various current limits and features. Consult the Maxim website for details.

A 3.3V regulator (for example, the MAX6349TL) powers the MAX3421E, and optionally the system controller. If the system controller operates with a lower voltage, the MAX3421E SPI and I/O interface can run at the lower voltage by connecting the system voltage (for example, 2.5V or 1.8V) to the MAX3421E V_L pin.

USB Peripheral/Host Controller with SPI Interface

Functional Diagram

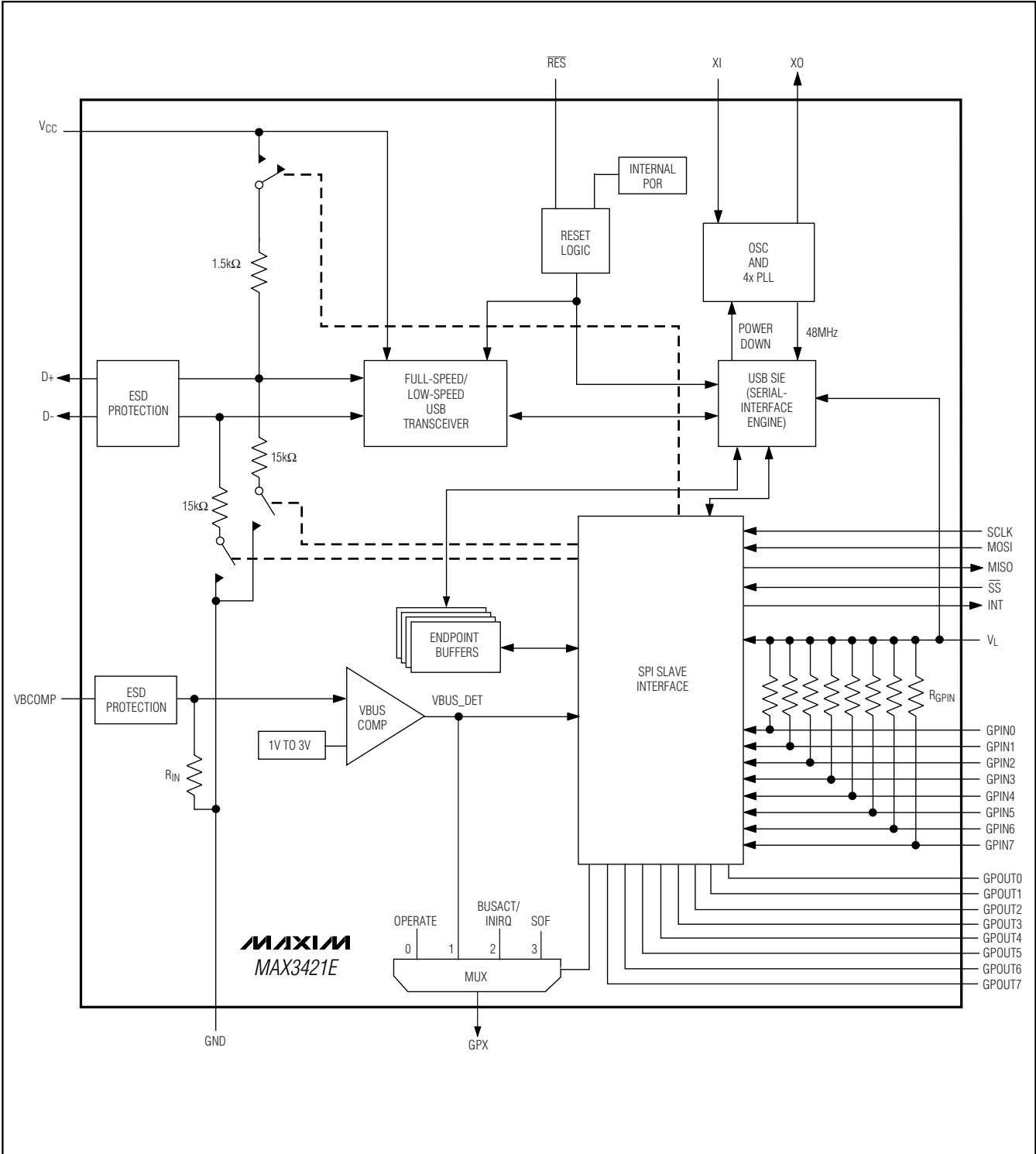

USB Peripheral/Host Controller with SPI Interface

Pin Description

MAX3421E

PIN	NAME	INPUT/ OUTPUT	FUNCTION
1	GPIN7	Input	General-Purpose Input. GPIN7–GPIN0 are connected to V_L with internal pullup resistors. GPIN7–GPIN0 logic levels are referenced to the voltage on V_L .
2	V_L	Input	Level-Translator Voltage Input. Connect V_L to the system's 1.4V to 3.6V logic-level power supply. Bypass V_L to ground with a 0.1 μ F capacitor as close to V_L as possible.
3, 19	GND	Input	Ground
4	GPOUT0	Output	General-Purpose Push-Pull Outputs. GPOUT7–GPOUT0 logic levels are referenced to the voltage on V_L .
5	GPOUT1		
6	GPOUT2		
7	GPOUT3		
8	GPOUT4		
9	GPOUT5		
10	GPOUT6		
11	GPOUT7		
12	$\overline{\text{RES}}$	Input	Device Reset. Drive $\overline{\text{RES}}$ low to clear all of the internal registers except for PINCTL (R17), USBCTL (R15), and SPI logic. The logic level is referenced to the voltage on V_L . (See the <i>Device Reset</i> section for a description of resets available on the MAX3421E.)
13	SCLK	Input	SPI Serial-Clock Input. An external SPI master supplies SCLK with frequencies up to 26MHz. The logic level is referenced to the voltage on V_L . Data is clocked into the SPI slave interface on the rising edge of SCLK. Data is clocked out of the SPI slave interface on the falling edge of SCLK.
14	$\overline{\text{SS}}$	Input	SPI Slave Select Input. The $\overline{\text{SS}}$ logic level is referenced to the voltage on V_L . When $\overline{\text{SS}}$ is driven high, the SPI slave interface is not selected, the MISO pin is high impedance, and SCLK transitions are ignored. An SPI transfer begins with a high-to-low $\overline{\text{SS}}$ transition and ends with a low-to-high $\overline{\text{SS}}$ transition.
15	MISO	Output	SPI Serial-Data Output (Master-In Slave-Out). MISO is a push-pull output. MISO is tri-stated in half-duplex mode or when $\overline{\text{SS}} = 1$. The MISO logic level is referenced to the voltage on V_L .
16	MOSI	Input or Input/ Output	SPI Serial-Data Input (Master-Out Slave-In). The logic level on MOSI is referenced to the voltage on V_L . MOSI can also be configured as a bidirectional MOSI/MISO input and output. (See Figure 15.)
17	GPX	Output	General-Purpose Multiplexed Push-Pull Output. The internal MAX3421E signal that appears on GPX is programmable by writing to the GPXB and GPXA bits of the PINCTL (R17) register and the SEPIRQ bit of the MODE (R27) register. GPX indicates one of five signals (see the <i>GPX</i> section).
18	INT	Output	Interrupt Output. In edge mode, the logic level on INT is referenced to the voltage on V_L and is a push-pull output with programmable polarity. In level mode, INT is open-drain and active low. Set the IE bit in the CPUCTL (R16) register to enable INT.
20	D-	Input/ Output	USB D- Signal. Connect D- to a USB connector through a 33 Ω \pm 1% series resistor. A switchable 15k Ω D- pulldown resistor is internal to the device.

USB Peripheral/Host Controller with SPI Interface

Pin Description (continued)

PIN	NAME	INPUT/ OUTPUT	FUNCTION
21	D+	Input/ Output	USB D+ Signal. Connect D+ to a USB connector through a $33\Omega \pm 1\%$ series resistor. A switchable $1.5k\Omega$ D+ pullup resistor and $15k\Omega$ D+ pulldown resistor is internal to the device.
22	VBCOMP	Input	V_{BUS} Comparator Input. VBCOMP is internally connected to a voltage comparator to allow the SPI master to detect (through an interrupt or checking a register bit) the presence or loss of power on V_{BUS} . Bypass VBCOMP to ground with a $1.0\mu F$ ceramic capacitor. VBCOMP is pulled down to ground with R_{IN} (see <i>Electrical Characteristics</i>).
23	VCC	Input	USB Transceiver and Logic Core Power-Supply Input. Connect V_{CC} to a positive 3.3V power supply. Bypass V_{CC} to ground with a $1.0\mu F$ ceramic capacitor as close to the V_{CC} pin as possible.
24	XI	Input	Crystal Oscillator Input. Connect XI to one side of a parallel resonant $12MHz \pm 0.25\%$ crystal and a load capacitor to GND. XI can also be driven by an external clock referenced to V_{CC} .
25	XO	Output	Crystal Oscillator Output. Connect XO to the other side of a parallel resonant $12MHz \pm 0.25\%$ crystal and a load capacitor to GND. Leave XO unconnected if XI is driven with an external source.
26	GPIN0	Input	General-Purpose Inputs. GPIN7–GPIN0 are connected to V_L with internal pullup resistors. GPIN7–GPIN0 logic levels are referenced to the voltage on V_L .
27	GPIN1		
28	GPIN2		
29	GPIN3		
30	GPIN4		
31	GPIN5		
32	GPIN6		
EP	GND	Input	Exposed Paddle, Connected to Ground. Connect EP to GND or leave unconnected. EP is located on the bottom of the TQFN package. The TQFP package does not have an exposed paddle.

USB Peripheral/Host Controller with SPI Interface

Register Description

The SPI master controls the MAX3421E by reading and writing 26 registers in peripheral mode (see Table 1) or reading and writing 23 registers in host mode (see Table 2). Setting the HOST bit in the MODE (R27) register configures the MAX3421E for host operation. When operating as a USB peripheral, the MAX3421E is register-compatible with the MAX3420E with the additional features listed in Note 1b below Table 1. For a complete description of register contents, refer to the *MAX3421E Programming Guide* on the Maxim website.

A register access consists of the SPI master first writing an SPI command byte followed by reading or writing the contents of the addressed register. All SPI transfers are MSB first. The command byte contains the register address, a direction bit (read = 0, write = 1), and the ACKSTAT bit (Figure 5). The SPI master addresses the MAX3421E registers by writing the binary value of the register number in the Reg4 through Reg0 bits of the command byte. For example, to access the IOPINS1 (R20) register, the Reg4 through Reg0 bits would be as follows: Reg4 = 1, Reg3 = 0, Reg2 = 1, Reg1 = 0, Reg0 = 0. The DIR (direction) bit determines the direction for the data transfer. DIR = 1 means the data byte(s) are written to the register, and DIR = 0 means the data byte(s) are read from the register. The ACKSTAT bit sets the ACKSTAT bit in the EPSTALLS (R9) register (peripheral mode only). The SPI master sets this bit to indicate that it has finished servicing a CONTROL transfer. Since the bit is frequently used, having it in the SPI command byte improves firmware efficiency. The ACKSTAT bit is ignored in host mode. In SPI full-duplex mode, the MAX3421E clocks out eight USB status bits as the com-

mand byte is clocked in (Figures 6, 7). In half-duplex mode, these status bits are accessed as register bits.

The first five registers (R0–R4) address FIFOs in both peripheral and host modes. Repeated accesses to these registers freeze the internal register address so that multiple bytes may be written to or read from a FIFO in the same SPI access cycle (while \overline{SS} is low). Accesses to registers R5–R19 increment the internal register address for every byte transferred during the SPI access cycle. Accessing R20 freezes access at that register, accessing R21–R31 increments the internal address, and repeated accesses to R31 freeze at R31.

The register maps in Table 1 and Table 2 show which register bits apply in peripheral and host modes. Register bits that do not apply to a particular mode are shown as zeros. These register bits read as zero values and should not be written to with a logic 1.

Register Map in Peripheral Mode

The MAX3421E maintains register compatibility with the MAX3420E when operating in USB peripheral mode (MAX3421E HOST bit is set to 0 (default)). Firmware written for the MAX3420E runs without modification on the MAX3421E. To support new MAX3421E features, the register set includes new bits, described in Note 1b at the bottom of Table 1.

Register Map in Host Mode

As Table 2 shows, in host mode (HOST = 1), some MAX3420E registers are renamed (for example R1 becomes RCVFIFO), some are not used (shown with zeros), and some still apply to host mode. In addition, 11 registers (R21–R31) add the USB host capability.

b7	b6	b5	b4	b3	b2	b1	b0
Reg4	Reg3	Reg2	Reg1	Reg0	0	DIR	ACKSTAT*

*The ACKSTAT bit is ignored in host mode.
Figure 5. SPI Command Byte

STATUS BITS (PERIPHERAL MODE)							
b7	b6	b5	b4	b3	b2	b1	b0
SUSPIRQ	URESIRQ	SUDAVIRQ	IN3BAVIRQ	IN2BAVIRQ	OUT1DAVIRQ	OUT0DAVIRQ	IN0BAVIRQ

Figure 6. USB Status Bits Clocked Out as First Byte of Every Transfer in Peripheral Mode (Full-Duplex Mode Only)

STATUS BITS (HOST MODE)							
b7	b6	b5	b4	b3	b2	b1	b0
HXFRDNIRQ	FRAMEIRQ	CONNIRQ	SUSDNIRQ	SNDBAVIRQ	RCVDAVIRQ	RSMREQIRQ	BUSEVENTIRQ

Figure 7. USB Status Bits Clocked Out as First Byte of Every Transfer in Host Mode (Full-Duplex Mode Only)

USB Peripheral/Host Controller with SPI Interface

MAX3421E

Table 1. MAX3421E Register Map in Peripheral Mode (HOST = 0) (Notes 1a, 1b)

REG	NAME	b7	b6	b5	b4	b3	b2	b1	b0	acc
R0	EP0FIFO	b7	b6	b5	b4	b3	b2	b1	b0	RSC
R1	EP1OUTFIFO	b7	b6	b5	b4	b3	b2	b1	b0	RSC
R2	EP2INFIFO	b7	b6	b5	b4	b3	b2	b1	b0	RSC
R3	EP3INFIFO	b7	b6	b5	b4	b3	b2	b1	b0	RSC
R4	SUDFIFO	b7	b6	b5	b4	b3	b2	b1	b0	RSC
R5	EP0BC	0	b6	b5	b4	b3	b2	b1	b0	RSC
R6	EP1OUTBC	0	b6	b5	b4	b3	b2	b1	b0	RSC
R7	EP2INBC	0	b6	b5	b4	b3	b2	b1	b0	RSC
R8	EP3INBC	0	b6	b5	b4	b3	b2	b1	b0	RSC
R9	EPSTALLS	0	ACKSTAT	STLSTAT	STLEP3IN	STLEP2IN	STLEP1OUT	STLEP0OUT	STLEP0IN	RSC
R10	CLRTOGS	EP3DISAB	EP2DISAB	EP1DISAB	CTGEP3IN	CTGEP2IN	CTGEP1OUT	0	0	RSC
R11	EPIRQ	0	0	SUDAVIRQ	IN3BAVIRQ	IN2BAVIRQ	OUT1DAVIRQ	OUT0DAVIRQ	IN0BAVIRQ	RC
R12	EPIEN	0	0	SUDAVIE	IN3BAVIE	IN2BAVIE	OUT1DAVIE	OUT0DAVIE	IN0BAVIE	RSC
R13	USBIRQ	URES DNIRQ	VBUSIRQ	NOVBUSIRQ	SUSPIRQ	URESIRQ	BUSACTIRQ	RWUDNIRQ	OSCOKIRQ	RC
R14	USBIEEN	URES DNIE	VBUSIE	NOVBUSIE	SUSPIE	URESIE	BUSACTIE	RWUDNIE	OSCOKIE	RSC
R15	USBCTL	HOSCSTEN	VBGATE	CHIPRES	PWRDOWN	CONNECT	SIGRWU	0	0	RSC
R16	CPUCTL	PULSEWID1	PULSEWID0	0	0	0	0	0	IE	RSC
R17	PINCTL	EP3INAK	EP2INAK	EP0INAK	FDUPSPI	INTLEVEL	POSINT	GPXB	GPXA	RSC
R18	REVISION	0	0	0	0	0	0	0	1	R
R19	FNADDR	0	b6	b5	b4	b3	b2	b1	b0	R
R20	IOPINS1	GPIN3	GPIN2	GPIN1	GPIN0	GPOUT3	GPOUT2	GPOUT1	GPOUT0	RSC
R21	IOPINS2	GPIN7	GPIN6	GPIN5	GPIN4	GPOUT7	GPOUT6	GPOUT5	GPOUT4	RSC
R22	GPINIRQ	GPINIRQ7	GPINIRQ6	GPINIRQ5	GPINIRQ4	GPINIRQ3	GPINIRQ2	GPINIRQ1	GPINIRQ0	RSC
R23	GPINIEN	GPINIEN7	GPINIEN6	GPINIEN5	GPINIEN4	GPINIEN3	GPINIEN2	GPINIEN1	GPINIEN0	RSC
R24	GPINPOL	GPINPOL7	GPINPOL6	GPINPOL5	GPINPOL4	GPINPOL3	GPINPOL2	GPINPOL1	GPINPOL0	RSC
R25	—	0	0	0	0	0	0	0	0	—
R26	—	0	0	0	0	0	0	0	0	—
R27	MODE	0	0	0	SEPIRQ	0	0	0	HOST = 0	RSC
R28	—	0	0	0	0	0	0	0	0	—
R29	—	0	0	0	0	0	0	0	0	—
R30	—	0	0	0	0	0	0	0	0	—
R31	—	0	0	0	0	0	0	0	0	—

Note 1a: The acc (access) column indicates how the SPI master can access the register.

R = read, RC = read or clear, RSC = read, set, or clear.

Writing to an R register (read only) has no effect.

Writing a 1 to an RC bit (read or clear) clears the bit.

Writing a zero to an RC bit has no effect.

USB Peripheral/Host Controller with SPI Interface

Table 1. MAX3421E Register Map in Peripheral Mode (HOST = 0) (Notes 1a, 1b) (Continued)

Note 1b: In peripheral mode, the MAX3421E performs identically to the MAX3420E with the following enhancements:

- 1) R16 adds the PULSEWID0 and PULSEWID1 bits to control the INT pulse width in edge interrupt mode (see Figure 12.) These bits default to the MAX3420E setting of 10.6µs.
- 2) R21 adds four more GPIO bits.
- 3) R22 and R23 add general-purpose input pins to the interrupt system. R24 controls the edge polarity.
- 4) R27 controls the peripheral/host mode and the SEPIRQ bit.
- 5) When [GPXB:GPXA] = [1:0] and the bit SEPIRQ = 1 (R27 bit 4), the GPX output replaces the BUSACT signal with a second IRQ pin dedicated to the GPIN pin interrupts.

Table 2. MAX3421E Register Map in Host Mode (HOST = 1) (Note 2)

REG	NAME	b7	b6	b5	b4	b3	b2	b1	b0	acc
R0	—	0	0	0	0	0	0	0	0	—
R1	RCVFIFO	b7	b6	b5	b4	b3	b2	b1	b0	RSC
R2	SNDFIFO	b7	b6	b5	b4	b3	b2	b1	b0	RSC
R3	—	0	0	0	0	0	0	0	0	—
R4	SUDFIFO	b7	b6	b5	b4	b3	b2	b1	b0	RSC
R5	—	0	0	0	0	0	0	0	0	—
R6	RCVBC	0	BC6	BC5	BC4	BC3	BC2	BC1	BC0	RSC
R7	SNDBC	0	BC6	BC5	BC4	BC3	BC2	BC1	BC0	RSC
R8	—	0	0	0	0	0	0	0	0	—
R9	—	0	0	0	0	0	0	0	0	—
R10	—	0	0	0	0	0	0	0	0	—
R11	—	0	0	0	0	0	0	0	0	—
R12	—	0	0	0	0	0	0	0	0	—
R13	USBIHQ	0	VBUSIRQ	NOVBUSIRQ	0	0	0	0	OSCOKIRQ	RC
R14	USBIEN	0	VBUSIE	NOVBUSIE	0	0	0	0	OSCOKIE	RSC
R15	USBCTL	0	0	CHIPRES	PWRDOWN	0	0	0	0	RSC
R16	CPUCTL	PULSEWID1	PULSEWID0	0	0	0	0	0	IE	RSC
R17	PINCTL	EP3INAK	EP2INAK	EP0INAK	FDUPSPI	INTLEVEL	POSINT	GPXB	GPXA	RSC
R18	REVISION	0	0	0	0	0	0	0	1	R
R19	—	0	0	0	0	0	0	0	0	—
R20	IOPINS1	GPIN3	GPIN2	GPIN1	GPIN0	GPOUT3	GPOUT2	GPOUT1	GPOUT0	RSC
R21	IOPINS2	GPIN7	GPIN6	GPIN5	GPIN4	GPOUT7	GPOUT6	GPOUT5	GPOUT4	RSC
R22	GPINIRQ	GPINIRQ7	GPINIRQ6	GPINIRQ5	GPINIRQ4	GPINIRQ3	GPINIRQ2	GPINIRQ1	GPINIRQ0	RC
R23	GPINIEN	GPINIEN7	GPINIEN6	GPINIEN5	GPINIEN4	GPINIEN3	GPINIEN2	GPINIEN1	GPINIEN0	RSC
R24	GPINPOL	GPINPOL7	GPINPOL6	GPINPOL5	GPINPOL4	GPINPOL3	GPINPOL2	GPINPOL1	GPINPOL0	RSC
R25	HIRQ	HXFRDNIRQ	FRAMEIRQ	CONNIRQ	SUSDNIRQ	SNDBAVIRQ	RCVDAVIRQ	RSMREQIRQ	BUSEVENTIRQ	RC
R26	HIEN	HXFRDNIE	FRAMEIE	CONNIE	SUSDNIE	SNDBAVIE	RCVDAVIE	RSMREQIE	BUSEVENTIE	RSC
R27	MODE	DPPULLDN	DMPULLDN	DELAYISO	SEPIRQ	SOFKAENAB	HUBPRE	SPEED	HOST = 1	RSC
R28	PERADDR	0	b6	b5	b4	b3	b2	b1	b0	RSC
R29	HCTL	SNDTOG1	SNDTOG0	RCVTOG1	RCVTOG0	SIGRSM	BUSSAMPLE	FRMRST	BUSRST	LS
R30	HXFR	HS	ISO	OUTNIN	SETUP	EP3	EP2	EP1	EP0	LS
R31	HRSL	JSTATUS	KSTATUS	SNDTOGRD	RCVTOGRD	HRSLT3	HRSLT2	HRSLT1	HRSLT0	R

USB Peripheral/Host Controller with SPI Interface

Table 2. MAX3421E Register Map in Host Mode (HOST = 1) (Note 2) (Continued)

Note 2: The acc (access) column indicates how the SPI master can access the register.
 R = read; RC = read or clear; RSC = read, set, or clear; LS = load-sensitive.
 Writing to an R register (read only) has no effect.
 Writing a 1 to an RC bit (read or clear) clears the bit.
 Writing a zero to an RC bit has no effect.
 Writing to an LS register initiates a host operation based on the contents of the register.

Pin Configurations

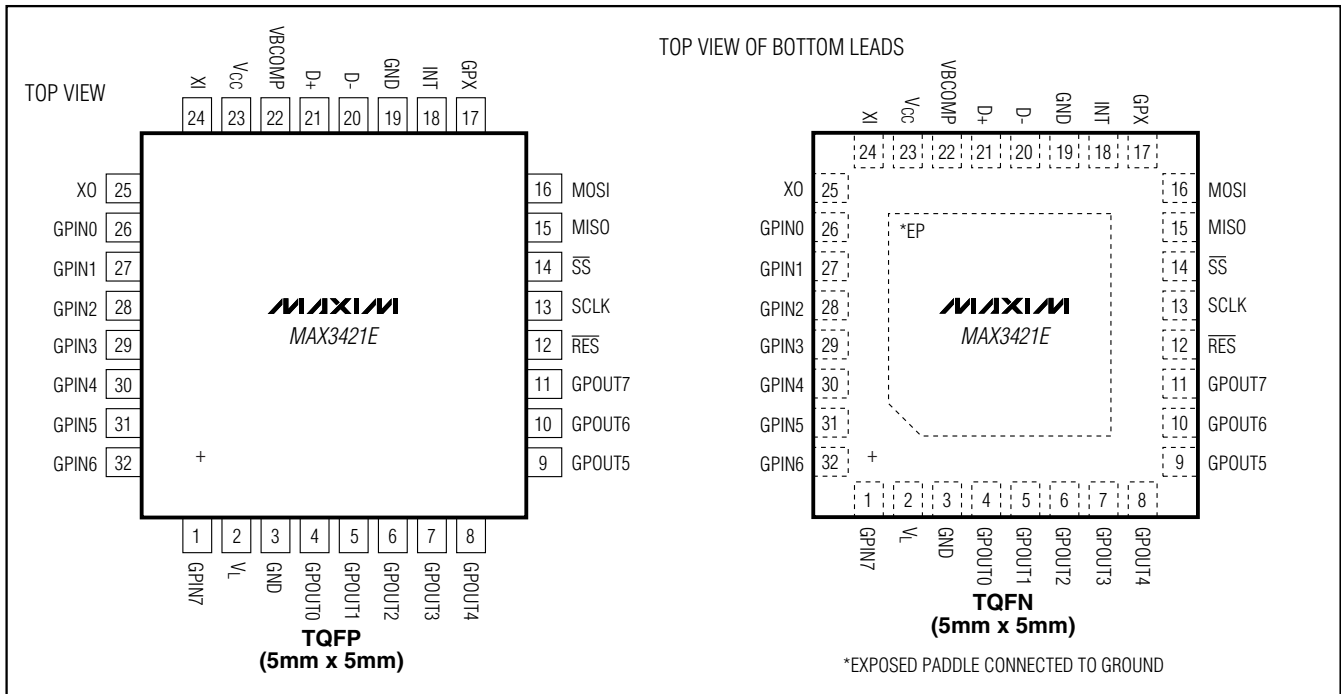

USB Peripheral/Host Controller with SPI Interface

MAX3421E

ABSOLUTE MAXIMUM RATINGS

(All voltages referenced to GND, unless otherwise noted.)

V _{CC}	-0.3V to +4V
V _L	-0.3V to +4V
V _{BCOMP}	-0.3V to +6V
D+, D-, XI, XO	-0.3V to (V _{CC} + 0.3V)
SCLK, MOSI, MISO, \overline{SS} , \overline{RES} , GPOUT7–GPOUT0, GPIN7–GPIN0, GPX, INT	-0.3V to (V _L + 0.3V)

Continuous Power Dissipation (T_A = +70°C)

32-Pin TQFN (derate 21.3mW/°C above +70°C)	1702mW
32-Pin TQFP (derate 13.1mW/°C above +70°C)	1047mW
Operating Temperature Range	-40°C to +85°C
Junction Temperature	+150°C
Storage Temperature Range	-65°C to +150°C
Lead Temperature (soldering, 10s)	+300°C

Stresses beyond those listed under "Absolute Maximum Ratings" may cause permanent damage to the device. These are stress ratings only, and functional operation of the device at these or any other conditions beyond those indicated in the operational sections of the specifications is not implied. Exposure to absolute maximum rating conditions for extended periods may affect device reliability.

ELECTRICAL CHARACTERISTICS

(V_{CC} = +3V to +3.6V, V_L = +1.4V to +3.6V, T_A = T_{MIN} to T_{MAX}, unless otherwise noted. Typical values are at V_{CC} = +3.3V, V_L = +2.5V, T_A = +25°C.) (Note 3)

PARAMETER	SYMBOL	CONDITIONS	MIN	TYP	MAX	UNITS
DC CHARACTERISTICS						
Supply Voltage V _{CC}	V _{CC}		3.0	3.3	3.6	V
Logic-Interface Voltage V _L	V _L		1.4		3.6	V
V _{CC} Supply Current	I _{CC}	Continuously transmitting on D+ and D- at 12Mbps, C _L = 50pF on D+ and D- to GND, CONNECT = 0			45	mA
V _L Supply Current	I _L	SCLK toggling at 20MHz, \overline{SS} = low, GPIN7–GPIN0 = 0		2.35	10	mA
V _{CC} Supply Current During Idle	I _{CCID}	D+ = high, D- = low		8.7	15	mA
V _{CC} Suspend Supply Current	I _{CCSUS}	CONNECT = 0, PWRDOWN = 1 (Note 4)		0.031	5	mA
V _L Suspend Supply Current	I _{LSUS}	CONNECT = 0, PWRDOWN = 1		20	50	μA
LOGIC-SIDE I/O						
MISO, GPOUT7–GPOUT0, GPX, INT Output High Voltage	V _{OH}	I _{LOAD} = +1mA	V _L - 0.4		V	
		I _{LOAD} = +5mA, V _L < 2.5V (Note 5)	V _L - 0.45			
		I _{LOAD} = +10mA, V _L ≥ 2.5V (Note 5)	V _L - 0.4			
MISO, GPOUT7–GPOUT0, GPX, INT Output Low Voltage	V _{OL}	I _{LOAD} = -1mA	0.4		V	
		I _{LOAD} = -20mA, V _L < 2.5V (Note 5)	0.6			
		I _{LOAD} = -20mA, V _L ≥ 2.5V (Note 5)	0.4			
SCLK, MOSI, GPIN7–GPIN0, \overline{SS} , \overline{RES} Input High Voltage	V _{IH}		2/3 × V _L		V	
SCLK, MOSI, GPIN7–GPIN0, \overline{SS} , \overline{RES} Input Low Voltage	V _{IL}		0.4		V	
SCLK, MOSI, \overline{SS} , \overline{RES} Input Leakage Current	I _{IL}		-1		+1	μA
GPIN7–GPIN0 Pullup Resistor to V _L	R _{GPIN}		10	20	30	kΩ
TRANSCEIVER SPECIFICATIONS						
Differential-Receiver Input Sensitivity		V _{D+} - V _{D-}	0.2			V

USB Peripheral/Host Controller with SPI Interface

MAX3421E

ELECTRICAL CHARACTERISTICS (continued)

(V_{CC} = +3V to +3.6V, V_L = +1.4V to +3.6V, T_A = T_{MIN} to T_{MAX}, unless otherwise noted. Typical values are at V_{CC} = +3.3V, V_L = +2.5V, T_A = +25°C.) (Note 3)

PARAMETER	SYMBOL	CONDITIONS	MIN	TYP	MAX	UNITS
Differential-Receiver Common-Mode Voltage			0.8		2.5	V
Single-Ended Receiver Input Low Voltage	V _{IL}				0.8	V
Single-Ended Receiver Input High Voltage	V _{IH}		2.0			V
Single-Ended Receiver Hysteresis Voltage				0.2		V
D+, D- Output Low Voltage	V _{OL}	R _L = 1.5kΩ from D+ to 3.6V			0.3	V
D+, D- Output High Voltage	V _{OH}	R _L = 15kΩ from D+ and D- to GND	2.8		3.6	V
Driver Output Impedance Excluding External Resistor		(Note 5)	2	7	11	Ω
D+ Pullup Resistor		R _{EXT} = 33Ω	1.425	1.5	1.575	kΩ
D+, D- Pulldown Resistor		R _{EXT} = 33Ω	14.25	15	15.75	kΩ
D+, D- Input Impedance			300			kΩ
ESD PROTECTION (D+, D-, VBCOMP)						
Human Body Model		1μF ceramic capacitors from VBCOMP and V _{CC} to GND		±15		kV
IEC 61000-4-2 Air-Gap Discharge		1μF ceramic capacitors from VBCOMP and V _{CC} to GND		±12		kV
IEC 61000-4-2 Contact Discharge		1μF ceramic capacitors from VBCOMP and V _{CC} to GND		±8		kV
THERMAL SHUTDOWN						
Thermal-Shutdown Low-to-High				+160		°C
Thermal-Shutdown High-to-Low				+140		°C
CRYSTAL OSCILLATOR SPECIFICATIONS (XI, XO)						
XI Input High Voltage			2/3 x V _{CC}		V _{CC}	V
XI Input Low Voltage					0.4	V
XI Input Current					10	μA
XI, XO Input Capacitance				3		pF
VBCOMP COMPARATOR SPECIFICATIONS						
VBCOMP Comparator Threshold	V _{TH}		1.0	2.0	3.0	V
VBCOMP Comparator Hysteresis	V _{HYS}			375		mV
VBCOMP Comparator Input Impedance	R _{IN}		100			kΩ

USB Peripheral/Host Controller with SPI Interface

MAX3421E

TIMING CHARACTERISTICS

(VCC = +3V to +3.6V, VL = +1.4V to +3.6V, TA = TMIN to TMAX, unless otherwise noted. Typical values are at VCC = +3.3V, VL = +2.5V, TA = +25°C.) (Note 3)

PARAMETER	SYMBOL	CONDITIONS	MIN	TYP	MAX	UNITS
USB TRANSMITTER TIMING CHARACTERISTICS (FULL-SPEED MODE)						
D+, D- Rise Time	tRISE	CL = 50pF, Figures 8 and 9	4		20	ns
D+, D- Fall Time	tFALL	CL = 50pF, Figures 8 and 9	4		20	ns
Rise-/Fall-Time Matching		CL = 50pF, Figures 8 and 9 (Note 5)	90		110	%
Output-Signal Crossover Voltage		CL = 50pF, Figures 8 and 9 (Note 5)	1.3		2.0	V
USB TRANSMITTER TIMING CHARACTERISTICS (HOST LOW-SPEED MODE)						
D+, D- Rise Time	tRISE	200pF ≤ CL ≤ 600pF, Figures 8 and 9	75		300	ns
D+, D- Fall Time	tFALL	200pF ≤ CL ≤ 600pF, Figures 8 and 9	75		300	ns
Rise-/Fall-Time Matching		200pF ≤ CL ≤ 600pF, Figures 8 and 9	80		120	%
Output-Signal Crossover Voltage		200pF ≤ CL ≤ 600pF, Figures 8 and 9	1.3		2.0	V
SPI BUS TIMING CHARACTERISTICS (VL = 2.5V) (Figures 10 and 11) (Note 6)						
Serial Clock (SCLK) Period (Note 7)	tCP	VL > 2.5V	38.4			ns
		VL = 1.4V	77.7			
SCLK Pulse-Width High	tCH		17			ns
SCLK Pulse-Width Low	tCL		17			ns
SS Fall to MISO Valid	tCSS		20			ns
SS Leading Time Before the First SCLK Edge	tL		30			ns
SS Trailing Time After the Last SCLK Edge	tT		30			ns
Data-In Setup Time	tDS		5			ns
Data-In Hold Time	tDH		10			ns
SS Pulse High	tCSW		200			ns
SCLK Fall to MISO Propagation Delay	tDO		14.2			ns
SCLK Fall to MOSI Propagation Delay	tDI		14.2			ns
SCLK Fall to MOSI Drive	tON		3.5			ns
SS High to MOSI High Impedance	tOFF				20	ns
SUSPEND TIMING CHARACTERISTICS						
Time-to-Enter Suspend		PWRDOWN = 1 to oscillator stop			5	μs
Time-to-Exit Suspend		PWRDOWN = 1 to 0 to OSCOKIRQ (Note 8)		3		ms

Note 3: Parameters are 100% production tested at TA = +25°C. Specifications over temperature are guaranteed by design.

Note 4: Redesign in progress to meet USB specification.

Note 5: Guaranteed by bench testing. Limits are not production tested.

Note 6: At VL = 1.4V to 2.5V, derate all the SPI timing characteristics by 50%. Not production tested.

Note 7: The minimum period is derived from SPI timing parameters.

Note 8: Time-to-exit suspend is dependent on the crystal used.

USB Peripheral/Host Controller with SPI Interface

Test Circuits and Timing Diagrams

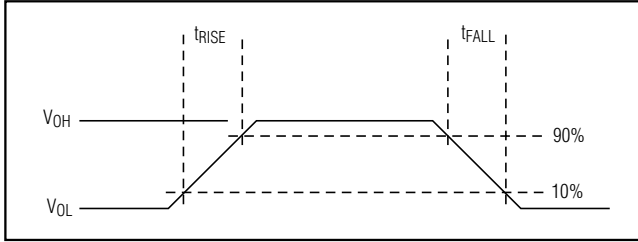

Figure 8. Rise and Fall Times

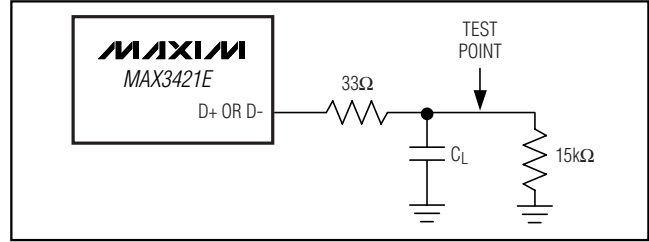

Figure 9. Load for D+/D- AC Measurements

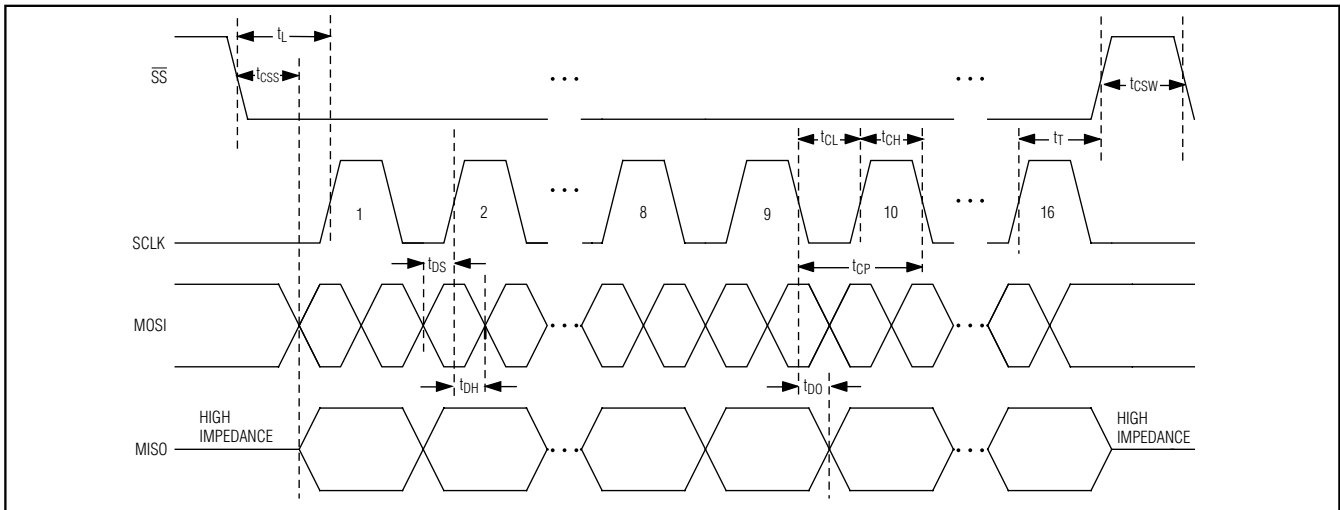

Figure 10. SPI Bus Timing Diagram (Full-Duplex Mode, SPI Mode (0,0))

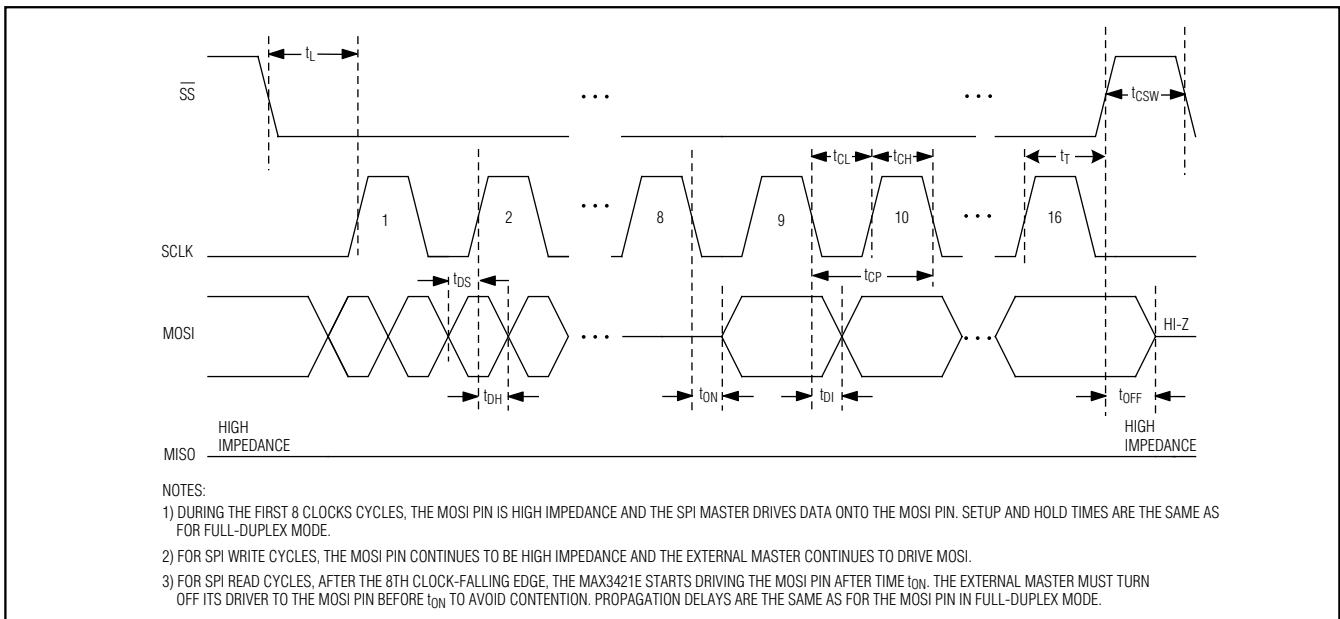

Figure 11. SPI Bus Timing Diagram (Half-Duplex Mode, SPI Mode (0,0))

USB Peripheral/Host Controller with SPI Interface

Typical Operating Characteristics

($V_{CC} = +3.3V$, $V_L = +3.3V$, $T_A = +25^\circ C$.)

MAX3421E

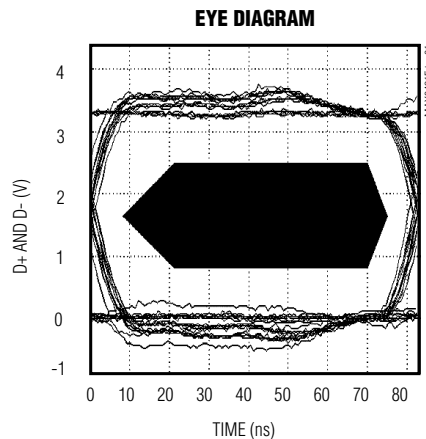

Detailed Description

The MAX3421E contains digital logic and analog circuitry necessary to implement a full-speed USB peripheral or a full-/low-speed host compliant to USB specification rev 2.0. The MAX3421E is selected to operate as either a host or peripheral by writing to the HOST bit in the MODE (R27) register. The MAX3421E features an internal USB transceiver with $\pm 15kV$ ESD protection on D+, D-, and VBCOMP. A switchable $1.5k\Omega$ pullup resistor is provided on D+ and switchable $15k\Omega$ pulldown resistors are provided on both D+ and D-. Any SPI master can communicate with the MAX3421E through the SPI slave interface that operates in SPI mode (0,0) or (1,1). An SPI master accesses the MAX3421E by reading and writing to internal registers. A typical data transfer consists of writing a first byte that sets a register address and direction with additional bytes reading or writing data to the register or internal FIFO.

In peripheral mode, the MAX3421E contains 384 bytes of endpoint buffer memory, implementing the following endpoints:

- EP0: 64-byte bidirectional CONTROL endpoint
- EP1: 2 x 64-byte double-buffered BULK/INT OUT endpoint
- EP2: 2 x 64-byte double-buffered BULK/INT IN endpoint
- EP3: 64-byte BULK/INT IN endpoint

The choice to use EP1, EP2, EP3 as BULK or INTERRUPT endpoints is strictly a function of the endpoint descriptors that the SPI master returns to the USB host during enumeration.

In host mode, the MAX3421E contains 256 bytes of send and receive FIFO memory:

- SNDFIFO: Send FIFO—double-buffered 64-byte FIFO
- RCVFIFO: Receive FIFO—double-buffered 64-byte FIFO

The host FIFOs can send SETUP, BULK, INTERRUPT, and ISOCHRONOUS requests to a peripheral device, at full speed or low speed. The MAX3421E accommodates low-speed devices whether they are directly connected, or connected through a USB hub. Because the MAX3421E does much of the host housekeeping, it is easy to program. The SPI master does a typical host operation by setting the device address and endpoint, launching a packet, and waiting for a completion interrupt. Then it examines transfer result bits to determine how the peripheral responded. It automatically generates frame markers (full-speed SOF packets or low-speed keep-alive pulses), and ensures that packets are dispatched at the correct times relative to these markers.

The MAX3421E register set and SPI interface is optimized to reduce SPI traffic. An interrupt output pin, INT, notifies the SPI master when USB service is required; for example, when a packet arrives, a packet is sent, or the host suspends or resumes bus activity. Double-buffered FIFOs

USB Peripheral/Host Controller with SPI Interface

help sustain bandwidth by allowing data to move concurrently over USB and the SPI interface.

V_{CC}

Power the USB transceiver and digital logic by applying a positive 3.3V supply to V_{CC}. Bypass V_{CC} to GND with a 1.0μF ceramic capacitor as close to the V_{CC} pin as possible.

V_L

V_L acts as a reference level for the SPI interface and all other digital inputs and outputs. Connect V_L to the system's logic-level power supply. Internal level translators and V_L allow the SPI interface and all general-purpose inputs and outputs to operate at a system voltage between 1.4V and 3.6V.

VBCOMP

The MAX3421E features a USB V_{BUS} detector input, VBCOMP. The VBCOMP pin can withstand input voltages up to 6V. Bypass VBCOMP to GND with a 1.0μF ceramic capacitor. VBCOMP is internally connected to a voltage comparator to allow the SPI master to detect (through an interrupt or checking a register bit) the presence or loss of power on V_{BUS}. VBCOMP does not power any internal circuitry inside the MAX3421E. VBCOMP is pulled down to ground with R_{IN} (see *Electrical Characteristics*).

VBCOMP in Peripheral Mode

VBCOMP is internally connected to a voltage comparator so that the SPI master can detect the presence or absence of V_{BUS}. According to the USB 2.0 specification, a self-powered peripheral must disconnect its 1.5kΩ pullup resistor to D+ in the event that the host turns off bus power. The VBGATE bit in the USBCTL (R15) register provides the option for the MAX3421E internal logic to automatically disconnect the 1.5kΩ resistor on D+. The VBGATE and CONNECT bits of USBCTL (R15), along with the VBCOMP comparator output (VBUS_DET), control the pullup resistor between V_{CC} and D+ as shown in Table 3 and the *Functional Diagram*. Note that if VBGATE = 1 and VBUS_DET = 0, the pullup resistor is disconnected regardless of the CONNECT bit setting. If the device using the MAX3421E is bus powered (through a +3.3V regulator connected to V_{CC}), the MAX3421E VBCOMP input can be used as a general-purpose input. See the *Applications Information* section for more details about this connection.

Table 3. Internal Pullup Resistor Control in Peripheral Mode

CONNECT	VBGATE	VBUS_DET	PULLUP
0	X	X	Not Connected
1	0	X	Connected
1	1	0	Not Connected
1	1	1	Connected

VBCOMP in Host Mode

When using the MAX3421E in host mode, the presence of V_{BUS} does not need to be detected. In this case, the VBCOMP input can be used as a general-purpose input.

D+ and D-

The internal USB full-/low-speed transceiver is brought out to the bidirectional data pins D+ and D-. These pins are ±15kV ESD protected. Connect D+ and D- to a USB B connector through 33Ω ±1% series resistors.

D+ and D- in Peripheral Mode

In peripheral mode, the D+ and D- pins connect to a USB B connector through series resistors. A switchable 1.5kΩ pullup resistor is internally connected to D+.

D+ and D- in Host Mode

In host mode, the D+ and D- pins connect to a USB A connector through series resistors. Switchable 15kΩ pulldown resistors are internally connected to D+ and D-. The DPPULLDN and DMPULLDN bits in the MODE (R27) register control the connection between D+ and D- to GND. For host operation, set these bits to 1 to enable the pulldown resistors. A host interrupt bit called CONNIRQ alerts the SPI master when a peripheral is attached or detached.

XI and XO

XI and XO connect an external 12MHz crystal to the internal oscillator circuit. XI is the crystal oscillator input, and XO is the crystal oscillator output. Connect one side of a 12MHz ±0.25% parallel resonant crystal to XI, and connect XO to the other side. Connect load capacitors (20pF max) to ground on both XI and XO. XI can also be driven with an external 12MHz ±0.25% clock. If driving XI with an external clock, leave XO unconnected. The external clock must meet the voltage characteristics depicted in the *Electrical Characteristics* table. Internal logic is single-edge triggered. The external clock should have a nominal 50% duty cycle.

USB Peripheral/Host Controller with SPI Interface

MAX3421E

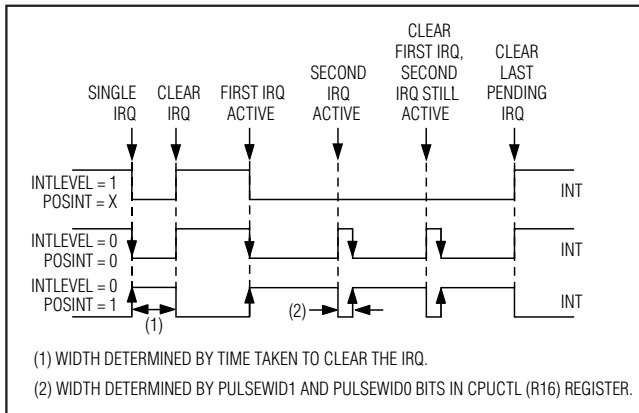

Figure 12. Behavior of the INT Pin for Different INTLEVEL and POSINT Bit Settings

Table 4. Pulse Width of INT Output Configured by PULSEWID1 and PULSEWID0

PULSEWID1	PULSEWID0	INT PULSE WIDTH (μ s)
0	0	10.6
0	1	5.3
1	0	2.6
1	1	1.3

enced to V_L any time an interrupt request is activated, or when an interrupt request is cleared and others are pending (Figure 12). Set the POSINT bit in the PINCTL (R17) register to make INT active high, and clear the POSINT bit to make INT active low. The PULSEWID1 and PULSEWID0 bits in the CPUCTL (R16) register control the pulse width of INT in edge mode as shown in Table 4.

RES

Drive \overline{RES} low to put the MAX3421E into a chip reset. A chip reset sets all registers to their default states, except for PINCTL (R17), USBCTL (R15), and SPI logic. All FIFO contents are unknown during chip reset. Bring the MAX3421E out of chip reset by driving \overline{RES} high. The RES pulse width can be as short as 200ns. See the *Device Reset* section for a description of the resets available on the MAX3421E.

INT

The MAX3421E INT output pin signals when a USB event occurs that requires the attention of the SPI master. INT can also be configured to assert when any of the general-purpose inputs (GPIN0–GPIN7) are activated (see the GPIN7–GPIN0 section for more details). The SPI master must set the IE bit in the CPUCTL (R16) register to activate INT. When the IE bit is cleared, INT is inactive (open for level mode, high for negative edge, low for positive edge). INT is inactive upon power-up or after a chip reset (IE = 0).

The INT pin can be a push-pull or open-drain output. Set the INTLEVEL bit of the PINCTL (R17) register high to program the INT output pin to be an active-low level open-drain output. An external pullup resistor to V_L is required for this setting. In level mode, the MAX3421E drives INT low when any of the interrupt flags are set. If multiple interrupts are pending, INT goes inactive only when the SPI master clears the last active interrupt request bit (Figure 12). The POSINT bit of the PINCTL (R17) register has no effect on INT in level mode.

Clear the INTLEVEL bit to program INT to be an edge active push-pull output. The active edge is programmable using the POSINT bit of the PINCTL (R17) register. In edge mode, the MAX3421E produces an edge refer-

GPIN7–GPIN0

The SPI master samples GPIN3–GPIN0 states by reading bit 7 through bit 4 of the IOPINS1 (R20) register. GPIN7–GPIN4 states are sampled by reading bit 7 through bit 4 of the IOPINS2 (R21) register. Writing to these bits has no effect.

Three registers, operational in both peripheral and host mode, control eight interrupt requests from the GPIN7–GPIN0 inputs. The GPINIRQ (R22) register contains the interrupt request flags for the eight GPIN inputs. The GPINIEN (R23) register contains individual interrupt enable bits for the eight GPIN interrupts. The GPINPOL (R24) register controls the edge polarity for the eight GPIN interrupts. The eight GPIN interrupts are added into the MAX3421E interrupt system and appear on the INT output pin if enabled and asserted. It is also possible to separate the GPIN interrupts and make them available on the GPX output pin by setting SEPIRQ = 1. This provides lower latency interrupt service since the source of the interrupt on the GPX output is known, and only the GPINIRQ register needs to be checked to determine the interrupt source. Note that the GPINPOL bits control the edge sensitivity of the GPIN transitions as they set an internal “interrupt pending” flip-flop, not the INT output pin. The INT pin output characteristics are determined by the INTLEVEL and POSINT register bits, as in the MAX3420E. If the GPX pin is configured as the GPIN INT pin, its output characteristics are the same as programmed for the INT pin.

USB Peripheral/Host Controller with SPI Interface

GPOUT7–GPOUT0

The SPI master controls the GPOUT3–GPOUT0 states by writing to bit 3 through bit 0 of the IOPINS1 (R20) register. GPOUT7–GPOUT4 states are controlled by writing to bit 3 through bit 0 of the IOPINS2 (R21) register. GPOUT7–GPOUT0 logic levels are referenced to the voltage on V_L . As shown in Figure 13, reading the state of a GPOUT7–GPOUT0 bit returns the state of the internal register bit, not the actual pin state. This is useful for doing read-modify-write operations to an output pin (such as blinking an LED), since the load on the output pin does not affect the register logic state.

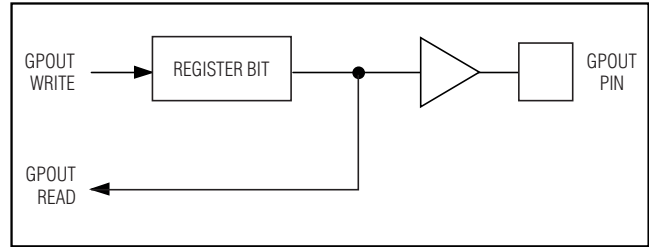

Figure 13. Behavior of Read and Write Operations on GPOUT3–GPOUT0

GPX

GPX is a push-pull output with a 4-way multiplexer that selects its output signal. The logic level on GPX is referenced to V_L . The SPI master writes to the GPXB and GPXA bits of PINCTL (R17) register to select one of five internal signals as depicted in Table 5.

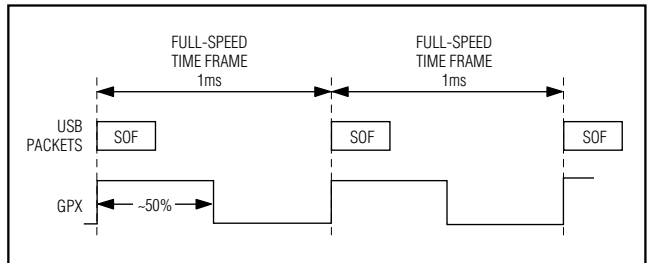

Figure 14. GPX Output in SOF Mode

Table 5. GPX Output State Due to GPXB and GPXA Bits

GPXB	GPXA	GPX PIN OUTPUT
0	0	OPERATE (Default State)
0	1	VBUS_DET
1	0	BUSACT/INIRQ*
1	1	SOF

*If SEPIRQ = 1.

- **OPERATE:** This signal goes high when the MAX3421E is able to operate after a power-up or \overline{RES} reset. OPERATE is active when the \overline{RES} input is high and the internal power-on-reset (POR) is not asserted. OPERATE is the default GPX output.
- **VBUS_DET:** VBUS_DET is the VBCOMP comparator output. This allows the user to directly monitor the VBUS status.
- **BUSACT:** USB BUS activity signal (active high). This signal is active whenever there is traffic on the USB bus. The BUSACT signal is set whenever a SYNC field is detected. BUSACT goes low during bus reset or after 32-bit times of J-state.

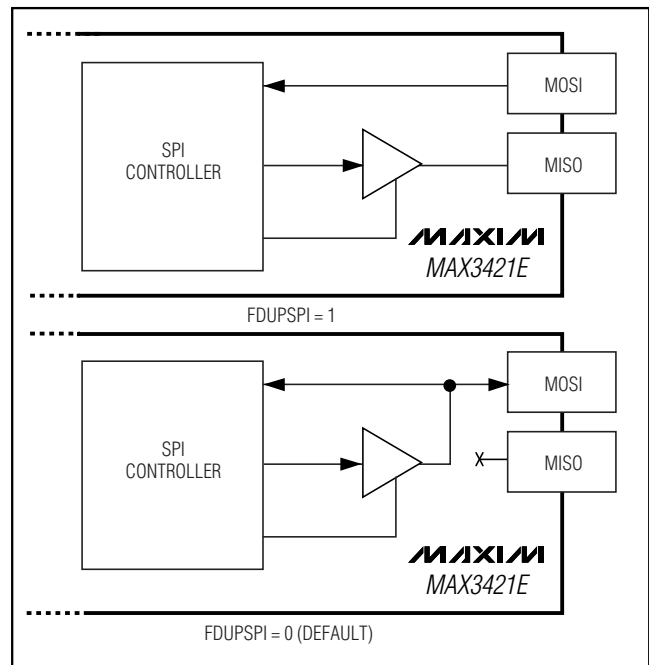

Figure 15. MAX3421E SPI Data Pins for Full-Duplex (Top) and Half-Duplex (Bottom) Operation

USB Peripheral/Host Controller with SPI Interface

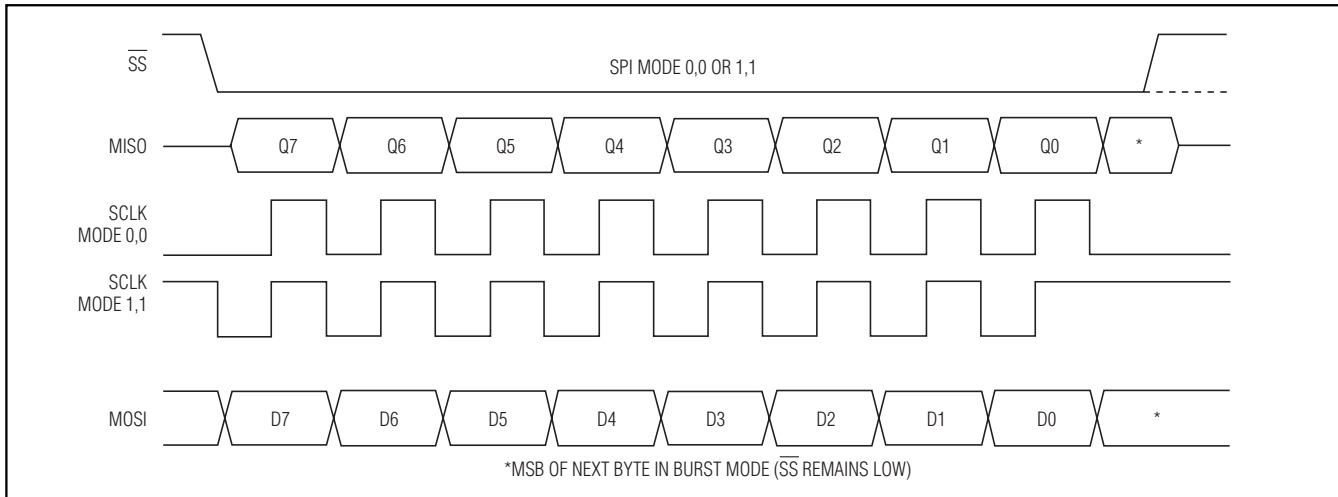

Figure 16. SPI Clocking Modes

- **INIRQ:** When the SEPIRQ bit of the MODE (R27) register is set high, the BUSACT signal is removed from the INT output and GPX is used as an IRQ output pin dedicated to GPIN interrupts if $GPX[B:A] = 10$. In this mode, GPIN interrupts appear only on the GPX pin, and do not appear on the INT output pin.
- **SOF:** A square wave with a positive edge that indicates the USB start-of-frame (Figure 14).

MOSI (Master-Out, Slave-In) and MISO (Master-In, Slave-Out)

The SPI data pins MOSI and MISO operate differently depending on the setting of a register bit called FDUPSPI (full-duplex SPI). Figure 15 shows the two configurations according to the FDUPSPI bit setting.

In full-duplex mode ($FDUPSPI = 1$), the MOSI and MISO pins are separate, and the MISO pin drives only when \overline{SS} is low. In this mode, the first eight SCLK edges (after $\overline{SS} = 0$) clock the command byte into the MAX3421E on MOSI, and 8 USB status bits are clocked out of the MAX3421E on MISO. For an SPI write cycle, any bytes following the command byte are clocked into the MAX3421E on MOSI, and zeros are clocked out on MISO. For an SPI read cycle, any bytes following the command byte are clocked out of the MAX3421E on MISO and the data on MOSI is ignored. At the conclusion of the SPI cycle ($\overline{SS} = 1$), the MISO output tri-states.

In half-duplex mode, the MOSI pin is a bidirectional pin and the MISO pin is tri-stated. This saves a pin in the SPI interface. Because of the shared data pin, this mode does not offer the 8 USB status bits (Figures 6 and 7) as

the command byte is clocked into the MAX3421E. The MISO pin can be left unconnected in half-duplex mode.

SCLK (Serial Clock)

The SPI master provides the MAX3421E SCLK signal to clock the SPI interface. SCLK has no low-frequency limit, and can be as high as 26MHz. The MAX3421E changes its output data (MISO) on the falling edge of SCLK and samples input data (MOSI) on the rising edge of SCLK. The MAX3421E ignores SCLK transitions when \overline{SS} is high. The inactive level of SCLK may be low or high, depending on the SPI operating mode (Figure 16).

\overline{SS} (Slave Select)

The MAX3421E SPI interface is active only when \overline{SS} is low. When \overline{SS} is high, the MAX3421E tri-states the SPI output pin and resets the internal MAX3421E SPI logic. If \overline{SS} goes high before a complete byte is clocked in, the byte-in-progress is discarded. The SPI master can terminate an SPI cycle after clocking in the first 8 bits (the command byte). This feature can be used in a full-duplex system to retrieve the USB status bits (Figure 6 and 7) without sending or receiving SPI data.

Applications Information

SPI Interface

The MAX3421E operates as an SPI slave device. A register access consists of the SPI master first writing an SPI command byte, followed by reading or writing the contents of the addressed register (see the *Register Description* section for more details). All SPI transfers are MSB first. The external SPI master provides a clock signal to the MAX3421E SCLK input. This clock frequency can be between DC and 26MHz. Bit transfers

USB Peripheral/Host Controller with SPI Interface

occur on the positive edge of SCLK. The MAX3421E counts bits and divides them into bytes. If fewer than 8 bits are clocked into the MAX3421E when \overline{SS} goes high, the MAX3421E discards the partial byte.

The MAX3421E SPI interface operates without adjustment in either SPI mode (CPOL = 0, CPHA = 0) or (CPOL = 1, CPHA = 1). No mode bit is required to select between the two modes since the interface uses the rising edge of the clock in both modes. The two clocking modes are illustrated in Figure 16. Note that the inactive SCLK value is different for the two modes. Figure 16 illustrates the full-duplex mode, where data is simultaneously clocked into and out of the MAX3421E.

SPI Half- and Full-Duplex Operation

The MAX3421E can be programmed to operate in half-duplex (a bidirectional data pin) or full-duplex (one data-in and one data-out pin) mode. The SPI master sets a register bit called FDUPSPI (full-duplex SPI) to 1 for full-duplex, and 0 for half-duplex operation. Half-duplex is the power-on default.

Full-Duplex Operation

When the SPI master sets FDUPSPI = 1, the SPI interface uses separate data pins, MOSI and MISO to transfer data. Because of the separate data pins, bits can be simultaneously clocked into and out of the MAX3421E. The MAX3421E makes use of this feature by clocking out 8 USB status bits as the command byte is clocked in. Figure 17 shows the status bits clocked out in peripheral mode and Figure 18 shows the status bits clocked out host mode.

Reading from the SPI Slave Interface (MISO)

The SPI master reads data from the MAX3421E slave interface using the following steps:

- 1) When \overline{SS} is high, the MAX3421E is unselected and tri-states the MISO output.
- 2) After driving SCLK to its inactive state, the SPI master selects the MAX3421E by driving \overline{SS} low. The MAX3421E turns on its MISO output buffer and places the first data bit (Q7) on the MISO output (Figure 16).
- 3) The SPI master simultaneously clocks the command byte into the MAX3421E MOSI pin, and USB status bits out of the MAX3421E MISO pin on the rising edges of the SCLK it supplies. The MAX3421E changes its MISO output data on the falling edges of SCLK.
- 4) After eight clock cycles, the master can drive \overline{SS} high to deselect the MAX3421E, causing it to tri-state its MISO output. The falling edge of the clock

puts the MSB of the next data byte in the sequence on the MISO output (Figure 16).

- 5) By keeping \overline{SS} low, the master clocks register data bytes out of the MAX3421E by continuing to supply SCLK pulses (burst mode). The master terminates the transfer by driving \overline{SS} high. The master must ensure that SCLK is in its inactive state at the beginning of the next access (when it drives \overline{SS} low). In full-duplex mode, the MAX3421E ignores data on MOSI while clocking data out on MISO.

Writing to the SPI Slave Interface (MOSI)

The SPI master writes data to the MAX3421E slave interface through the following steps:

- 1) The SPI master sets the clock to its inactive state. While \overline{SS} is high, the master can drive the MOSI input.
- 2) The SPI master selects the MAX3421E by driving \overline{SS} low and placing the first data bit to write on the MOSI input.
- 3) The SPI master simultaneously clocks the command byte into the MAX3421E and USB status bits out of the MAX3421E MISO pin on the rising edges of the SCLK it supplies. The SPI master changes its MOSI input data on the falling edges of SCLK.
- 4) After eight clock cycles, the master can drive \overline{SS} high to deselect the MAX3421E.
- 5) By keeping \overline{SS} low, the master clocks data bytes into the MAX3421E by continuing to supply SCLK pulses (burst mode). The master terminates the transfer by driving \overline{SS} high. The master must ensure that SCLK is inactive at the beginning of the next access (when it drives \overline{SS} low). In full-duplex mode, the MAX3421E outputs USB status bits on MISO during the first 8 bits (the command byte), and subsequently outputs zeros on MISO as the SPI master clocks bytes into MOSI.

Half-Duplex Operation

The MAX3421E is put into half-duplex mode at power-on, or when the SPI master clears the FDUPSPI bit. In half-duplex mode, the MAX3421E tri-states its MISO pin and makes the MOSI pin bidirectional, saving a pin in the SPI interface. The MISO pin can be left unconnected in half-duplex operation.

Because of the single data pin, the USB status bits available in full-duplex mode are not available as the SPI master clocks in the command byte. In half-duplex mode these status bits are accessed in the normal way, as register bits.

The SPI master must operate the MOSI pin as bidirectional. It accesses a MAX3421E register as follows:

USB Peripheral/Host Controller with SPI Interface

MAX3421E

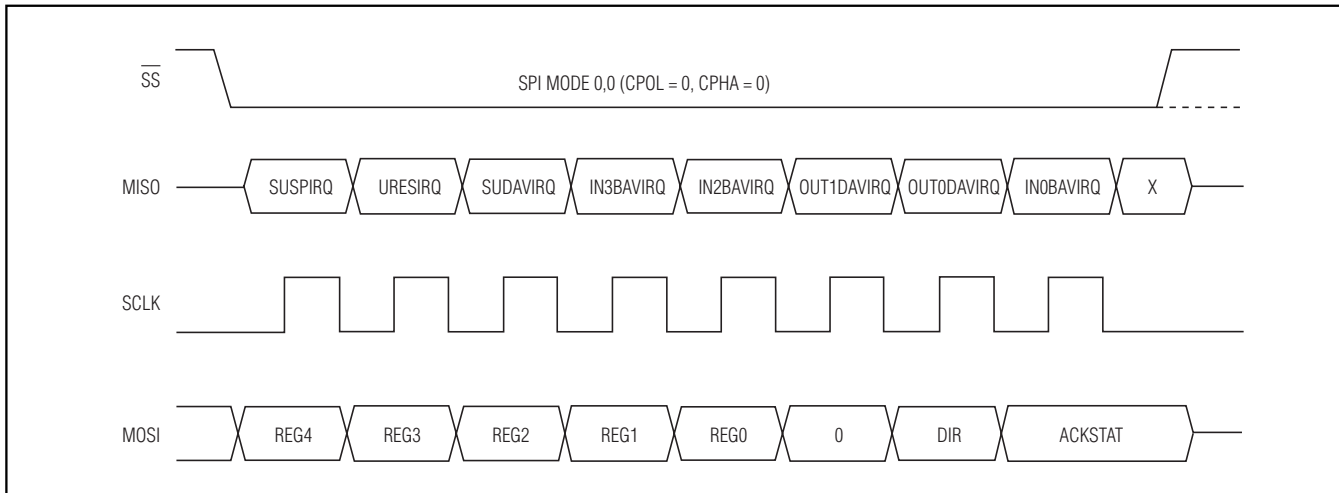

Figure 17. SPI Port in Full-Duplex Mode (Peripheral Mode)

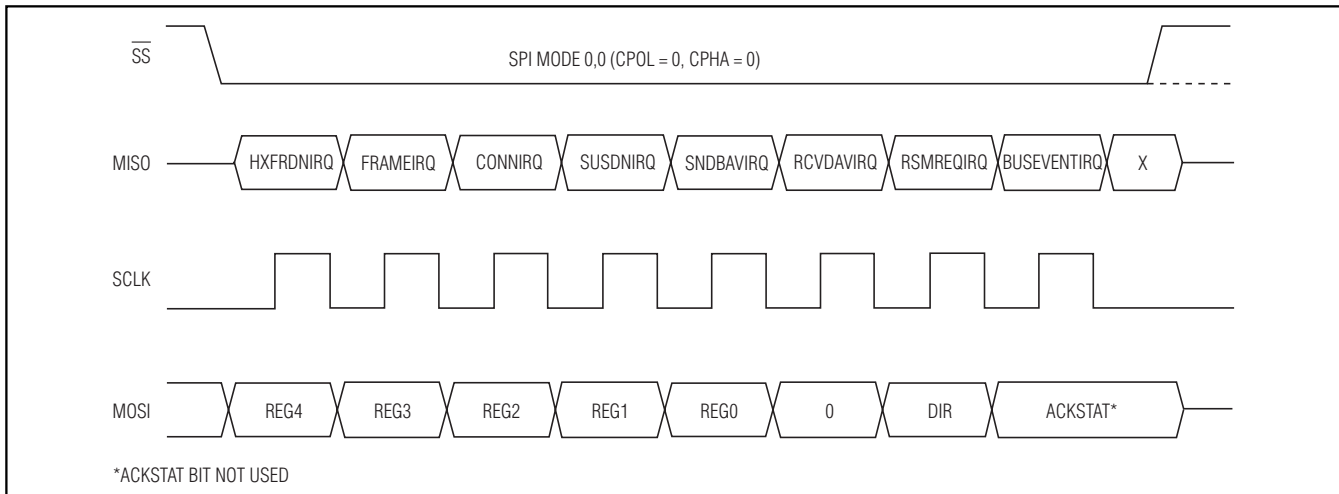

Figure 18. SPI Port in Full-Duplex Mode (Host Mode)

- 1) The SPI master sets the clock to its inactive state. While \overline{SS} is high, the master can drive the MOSI pin to any value.
 - 2) The SPI master selects the MAX3421E by driving \overline{SS} low and placing the first data bit (MSB) to write on the MOSI input.
 - 3) The SPI master turns on its output driver and clocks the command byte into the MAX3421E on the rising edges of the SCLK it supplies. The SPI master changes its MOSI data on the falling edges of SCLK.
 - 4) After eight clock cycles, the master can drive \overline{SS} high to deselect the MAX3421E.
 - 5) To write SPI data, the SPI master keeps its output driver on and clocks subsequent bytes into the MOSI pin. To read SPI data, after the eighth clock cycle the SPI master tri-states its output driver and begins clocking in data bytes from the MOSI pin.
 - 6) The SPI master terminates the SPI cycle by returning \overline{SS} high.
- Figures 10 and 11 show timing diagrams for full- and half-duplex operation.

USB Serial-Interface Engine

The serial-interface engine (SIE) does most of the detailed work required by USB protocol:

USB Peripheral/Host Controller with SPI Interface

- USB packet PID detection and checking
- CRC check and generation
- Automatic retries in case of errors
- USB packet generation
- NRZI data encoding and decoding
- Bit stuffing and unstuffing
- USB error detection
- USB bus reset, suspend, and wake-up detection
- USB suspend/resume signaling
- Automatic flow control (NAK)

PLL

An internal PLL multiplies the 12MHz oscillator signal by four to produce an internal 48MHz clock. When the chip is powered down, the oscillator is turned off to conserve power. When repowered, the oscillator and PLL require time to stabilize and lock. The OSCOKIRQ interrupt bit is used to indicate to the SPI master that the clocking system is stable and ready for operation.

The oscillator and PLL can be turned off by setting the PWRDOWN bit in the USBCTL (R15) register (see the *Suspend* section).

Power Management

According to USB rev. 2.0 specification, when a USB host stops sending traffic for at least 3ms to a peripheral, the peripheral must enter a power-down state called SUSPEND. Once suspended, the peripheral must have enough of its internal logic active to recognize when the host resumes signaling, or if enabled for remote wakeup, that the SPI master wishes to signal a resume event. The following sections titled *Suspend* and *Wakeup and USB Resume* describe how the SPI master coordinates with the MAX3421E to accomplish this power management.

Suspend

After 3ms of USB bus inactivity, a USB peripheral is required to enter the USB suspend state and draw no more than 500 μ A of V_{BUS} current. The suspend state is handled differently depending on whether the MAX3421E is used as a host or as a peripheral.

Suspend in Host Mode

In host mode, the MAX3421E suspends the bus by setting SOFKAEN = 0. This stops automatic generation of the 1ms frame signals (SOF for full speed, keep-alive for low speed).

Suspend in Peripheral Mode

In peripheral mode, after 3ms of USB bus inactivity, the MAX3421E sets the SUSPIRQ bit in the USBIRQ (R13) register and asserts the INT output, if SUSPIE = 1 and IE = 1. The SPI master must do any necessary power-saving housekeeping and then set the PWRDOWN bit in the USBCTL (R15) register. This instructs the MAX3421E to enter a power-down state, in which it does the following:

- Stops the 12MHz oscillator
- Keeps the INT output active (according to the mode set in the PINCTL (R17) register)
- Monitors the USB D+ line for a low level
- Monitors the SPI port for any traffic

Note that the MAX3421E does not automatically enter a power-down state after 3ms of bus inactivity. This allows the SPI master to perform any preshutdown tasks before it requests the MAX3421E to enter the power-down state by setting PWRDOWN = 1.

Wakeup and USB Resume

Wakeup and USB resume are handled differently depending on whether the MAX3421E is used as a host or as a peripheral.

Wakeup and USB Resume in Host Mode

After a host has suspended the bus by setting SOFKAEN = 0, it can resume bus traffic in two ways:

- 1) The SPI master initiates a host resume operation by setting the bit SIGRSM = 1. The MAX3421E asserts the resume signaling for 20ms, and then asserts the BUSEVENTIRQ bit. The SPI master then sets SOFKAEN = 1 to generate the 1ms frame markers that keep the peripheral alive.
- 2) The host recognizes a remote wakeup signal from a peripheral. The MAX3421E has an interrupt bit for this purpose called RSMREQIRQ (resume request IRQ).

Wakeup and USB Resume in Peripheral Mode

The MAX3421E can wake up in three ways while it is a peripheral in the power-down state:

- 1) The SPI master clears the PWRDOWN bit in the USBCTL (R15) register (this is also achieved by a chip reset).
- 2) The SPI master signals a USB remote wakeup by setting the SIGRWU bit in the USBCTL (R15) register. When SIGRWU = 1 the MAX3421E restarts the oscillator and waits for it to stabilize. After the oscillator stabilizes, the MAX3421E drives RESUME signaling (a 10ms K-state) on the bus. The MAX3421E times this interval to relieve the SPI master of having to keep accurate time. The MAX3421E also ensures

USB Peripheral/Host Controller with SPI Interface

that the RESUME signal begins only after at least 5ms of the bus idle state. When the MAX3421E finishes its RESUME signaling, it sets the RWUDNIRQ (remote wake-up done interrupt request) interrupt flag in the USBIRQ (R13) register. At this time the SPI master should clear the SIGRWU bit.

- 3) The host resumes bus activity. To enable the MAX3421E to wake up from host signaling, the SPI master sets the HOSCSTEN (host oscillator start enable) bit of the USBCTL (R15) register. While in this mode, if the MAX3421E detects a 1 to 0 transition on D+, the MAX3421E restarts the oscillator and waits for it to stabilize.

Device Reset

The MAX3421E has three reset mechanisms:

- Power-On Reset. This is the most inclusive reset (sets all internal register bits to a known state).
- Chip Reset. The SPI master can assert a chip reset by setting the bit CHIPRES = 1, which has the same effect as pulling the $\overline{\text{RES}}$ pin low. This reset clears only some register bits and leaves others alone.
- USB Bus Reset. A USB bus reset is the least inclusive (clears the smallest number of bits).

Note: A power-on or chip reset clears the host bit and puts the MAX3421E into peripheral mode.

Power-On Reset

At power-on, all register bits except 3 are cleared. The following 3 bits are set to 1 to indicate that the IN FIFOs are available for loading by the SPI master (BAV = buffer available):

- IN3BAVIRQ
- IN2BAVIRQ
- IN0BAVIRQ

Chip Reset

Pulling the $\overline{\text{RES}}$ pin low or setting CHIPRES = 1 clears most of the bits that control USB operation, but keeps the SPI and pin-control bits unchanged so the interface between the SPI master and the MAX3421E is not disturbed. Specifically:

- CHIPRES is unchanged. If the SPI master asserted this reset by setting CHIPRES = 1, it removes the reset by writing CHIPRES = 0.
- CONNECT is unchanged, keeping the device connected if CONNECT = 1.
- General-purpose outputs GPOUT7–GPOUT0 are unchanged, preventing output glitches.

- The GPX output selector (GPXB, GPXA) is unchanged.
- The bits that control the SPI interface are unchanged: FDUPSPI, INTLEVEL, and POSINT.
- The bits that control power-down and wakeup behavior are unchanged: HOSCSTEN, PWRDOWN, and SIGRWU.

All other bits except the three noted in the *Power-On Reset* section are cleared.

Note: The IRQ and IE bits are cleared using this reset. This means that firmware routines that enable interrupts should be called after a reset of this type. GPOUT7–GPOUT0 are left unchanged during chip reset. They are only cleared by an internal POR.

USB Bus Reset in Peripheral Mode

When the MAX3421E detects 21.33 μ s of SE0, it asserts the URESIRQ bit, and clears certain bits. This reset is the least inclusive of the three resets. It maintains the bit states listed in the *Power-On Reset* and *Chip Reset* sections, plus it leaves the following bits in their previous states:

- EPFIFO registers are unchanged.
- The GPOUT7–GPOUT0 bits are unchanged.
- The IE bit is unchanged.
- URESIE/IRQ and URESDNIE/IRQ are unchanged, allowing the SPI master to check the state of USB bus reset.

The EPFIFO registers are left in their pre-USB bus reset states only for diagnostic purposes. Their values should be considered invalid after a bus reset. The actual data in the FIFOs is never cleared.

As with the chip reset, most of the interrupt request and interrupt enable bits are cleared, meaning that the device firmware must re-enable individual interrupts after a bus reset. The exceptions are the interrupts associated with the actual bus reset, allowing the SPI master to detect the beginning and end of the host signaling USB bus reset.

USB Bus Reset in Host Mode

As a host, an SPI master instructs the MAX3421E to generate a USB bus reset by setting the BUSRST bit in the HCTL register (R29). The MAX3421E generates the correctly timed signal, and asserts the BUSEVENTIRQ bit in the HIRQ register (R25) at completion.

Crystal Selection

The MAX3421E requires a crystal with the following specifications:

Frequency: 12MHz \pm 0.25%

USB Peripheral/Host Controller with SPI Interface

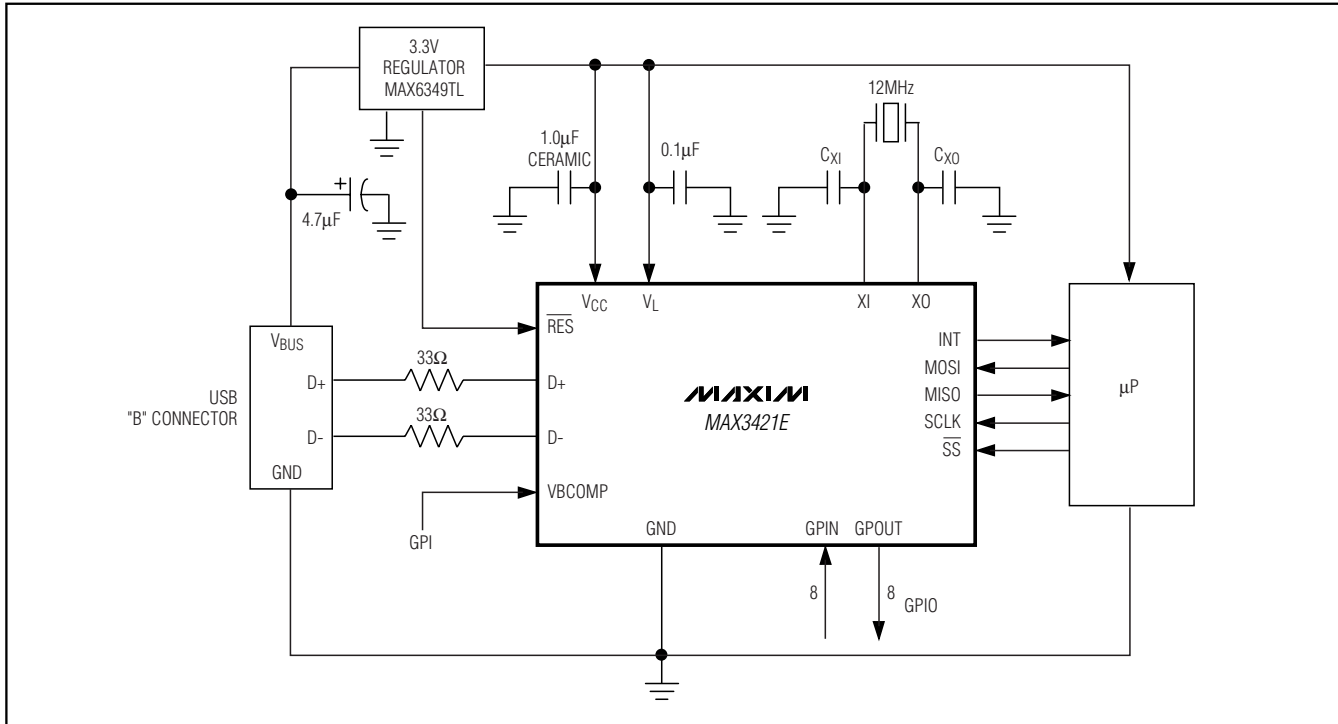

Figure 19. MAX3421E in a Bus-Powered Peripheral Application

C_{LOAD} : 18pF (max)

C_O : 7pF (max)

Drive level: 200µW

Series resonance resistance: 60Ω (max)

Note: Series resonance resistance is the resistance observed when the resonator is in the series resonant condition. This is a parameter often stated by quartz crystal vendors and is called R1. When a resonator is used in the parallel resonant mode with an external load capacitance, as is the case with the MAX3421E oscillator circuit, the effective resistance is sometimes stated. This effective resistance at the loaded frequency of oscillation is:

$$R1 \times (1 + (C_O / C_{LOAD}))^2$$

For typical C_O and C_{LOAD} values, the effective resistance can be greater than R1 by a factor of 2.

MAX3421E in a Bus-Powered Peripheral Application

Figure 19 depicts the MAX3421E in a peripheral device that is powered by VBUS. This configuration is advantageous because it requires no external power supply. VBUS is specified from 4.75V to 5.25V, requiring a 3.3V regulator to power the MAX3421E. This diagram

assumes that the microprocessor is powered by 3.3V as well, so the VL pin (logic-level reference voltage) is connected to VCC. Therefore, the GPIOs (general-purpose inputs/outputs) are referenced to 3.3V.

USB is a hot-plug system (VBUS is powered when the device is plugged in), so it is good design practice to use a power-on reset circuit to provide a clean reset to the system when the device is plugged in. The MAX6349TL serves as an excellent USB regulator, since it has very low quiescent current and a POR circuit built in.

Because this design is bus powered, it is not necessary to test for the presence of VBUS. In this case, the bus voltage-detection input, VBCOMP, makes an excellent general-purpose input. The VBCOMP input has two interrupts associated with it, VBUSIRQ and NOVBUSIRQ. These interrupts can detect both edges of any transitions on the VBCOMP input.

The configuration in Figure 19 shows the SPI interface using the maximum number of SPI interface pins. The data pins, MOSI and MISO, are separate, and the MAX3421E supplies an interrupt signal through the INT output pin to the µP to notify the µP when its attention is required.

USB Peripheral/Host Controller with SPI Interface

MAX3421E

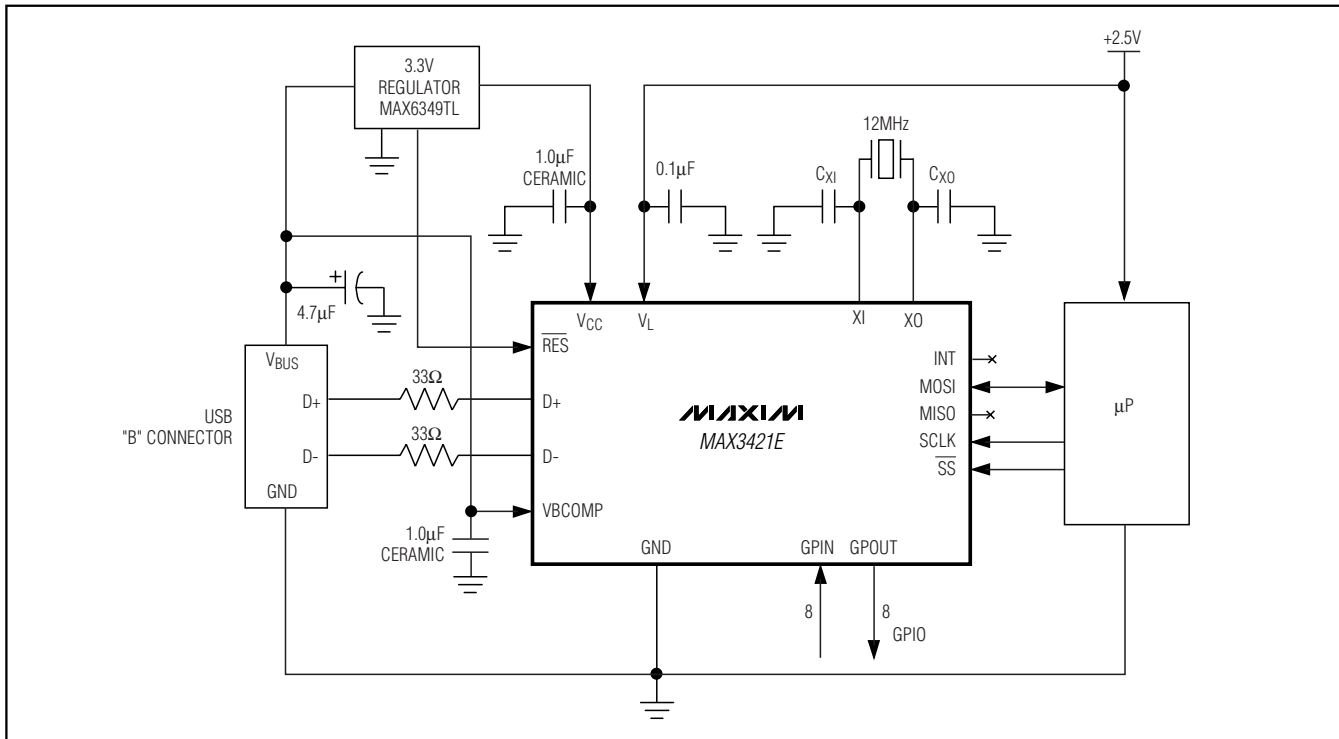

Figure 20. MAX3421E in a Self-Powered Peripheral Application

MAX3421E in a Self-Powered Application

Figure 20 shows a self-powered peripheral design in which the μP has its own power source. This is a common configuration in battery-powered handheld devices. Figure 20 also illustrates the SPI interfacing with the minimum number of pins. This is achieved by using a single bidirectional data line and no interrupt pin connection. The MAX3421E register bit, FDUPSPI, configures the SPI interface for bidirectional operation.

Although the system side is shown as powered by 2.5V, the MAX3421E actually accepts interface voltages of 1.4V to 3.6V. By connecting the system supply voltage to V_L , the level translators inside the MAX3421E adjust the GPIO and SPI bus pins to use the V_L reference, in this case 2.5V.

The V_{BUS} detect input, VBCOMP, is an important MAX3421E feature. Because the μP is powered whether the USB device is plugged in or not, it needs some way to detect a plug-in event. A comparator inside the MAX3421E checks for a valid V_{BUS} connection on VBCOMP and provides a connect status bit to the μP . Once connected, the μP can delay the logical connection to the USB bus to perform any required initialization, and then connect by setting the CONNECT bit to 1 in the MAX3421E register USBCTL (R15). This

connects the internal 1.5k Ω resistor from D+ to 3.3V, to signal the host that a device has been plugged in.

If a host turns off V_{BUS} while the device is connected, the USB rev. 2.0 specification requires that the device must not power its 1.5k Ω pullup resistor connected to D+. The MAX3421E has two features to help service this event. First, the NOVBSIRQ bit indicates the loss of V_{BUS} . Second, the μP can set a bit called VBGATE (V_{BUS} gate) to instruct the MAX3421E to disconnect the pullup resistor anytime V_{BUS} goes away, regardless of the CONNECT bit setting.

MAX3421E in a Host Application

Figure 21 illustrates the MAX3421E operating as an embedded host. A host supplies V_{BUS} power to a peripheral; therefore, this circuit requires an external 5V supply. A circuit that provides power to external devices should include power protection (the MAX4793, for example, which limits current from 300mA to 400mA) to ensure that the circuit can continue to operate if the plugged-in device causes an overcurrent condition. The FLAG indicator of the overcurrent switch connects to one of the eight MAX3421E GPIN inputs, and the GPX pin is configured to serve as a second MAX3421E interrupt pin that activates only when a GPIN pin changes state. One of the

USB Peripheral/Host Controller with SPI Interface

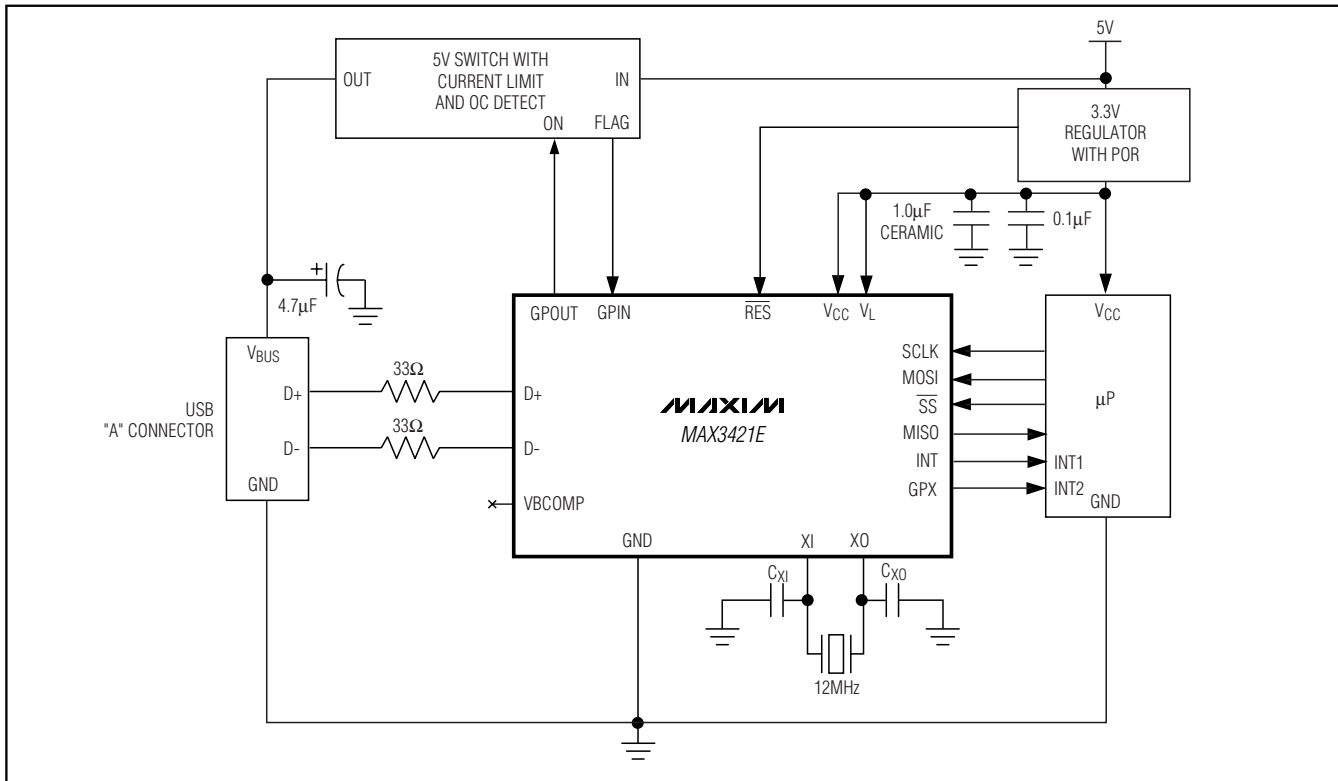

Figure 21. MAX3421E in a Host Application

eight GPOUT pins turns the V_{BUS} switch on and off. Seven MAX3421E GPIN and GPOUT pins are available to the system.

Short-Circuit Protection

The MAX3421E withstands V_{BUS} shorts to D+ and D- on the USB connector side of the 33Ω series resistors.

ESD Protection

D+, D-, and VBCOMP possess extra protection against static electricity to protect the devices up to ±15kV. The ESD structures withstand high ESD in all operating modes: normal operation, suspend mode, and powered down. VBCOMP and V_{CC} require 1µF ceramic capacitors connected to ground as close to the pins as possible. D+, D-, and VBCOMP provide protection to the following limits:

- ±15kV using the Human Body Model
- ±8kV using the Contact Discharge method specified in IEC 61000-4-2
- ±12kV using the IEC 61000-4-2 Air Gap Method

ESD Test Conditions

ESD performance depends on a variety of conditions. Contact Maxim for a reliability report that documents test setup, test methodology, and test results.

Human Body Model

Figure 22 shows the Human Body Model, and Figure 23 shows the current waveform generated when discharged into a low impedance. This model consists of a 100pF capacitor charged to the ESD voltage of interest, which then discharges into the test device through a 1.5kΩ resistor.

IEC 61000-4-2

The IEC 61000-4-2 standard covers ESD testing and performance of finished equipment. It does not specifically refer to integrated circuits. The major difference between tests done using the Human Body Model and IEC 61000-4-2 is a higher peak current in IEC 61000-4-2, due to lower series resistance. Hence, the ESD withstand voltage measured to IEC 61000-4-2 generally is lower than that measured using the Human Body

USB Peripheral/Host Controller with SPI Interface

MAX3421E

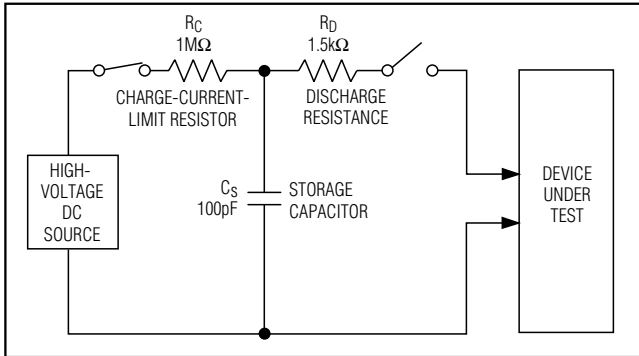

Figure 22. Human Body ESD Test Models

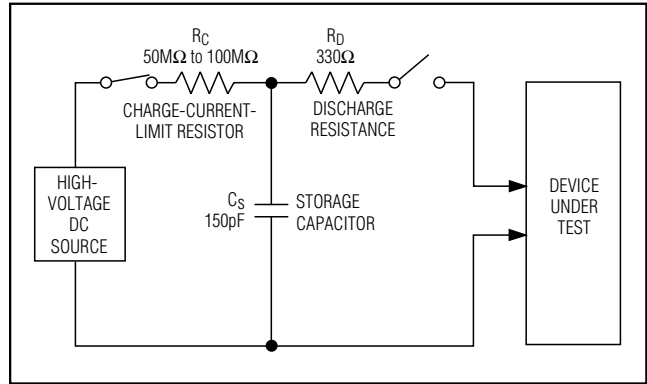

Figure 24. IEC 61000-4-2 ESD Test Model

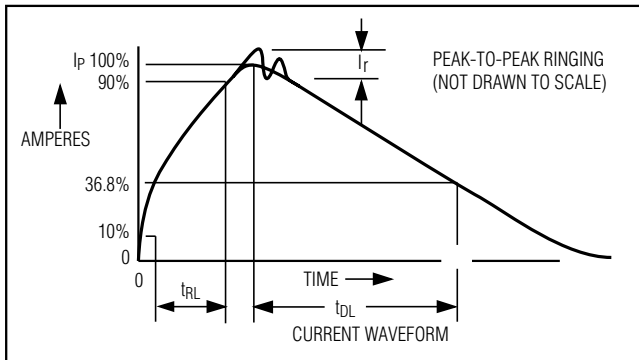

Figure 23. Human Body Model Current Waveform

Model. Figure 24 shows the IEC 61000-4-2 model. The Contact Discharge method connects the probe to the device before the probe is charged. The Air-Gap Discharge test involves approaching the device with a charged probe.

Chip Information

PROCESS: BiCMOS

USB Peripheral/Host Controller with SPI Interface

Package Information

(The package drawing(s) in this data sheet may not reflect the most current specifications. For the latest package outline information go to www.maxim-ic.com/packages.)

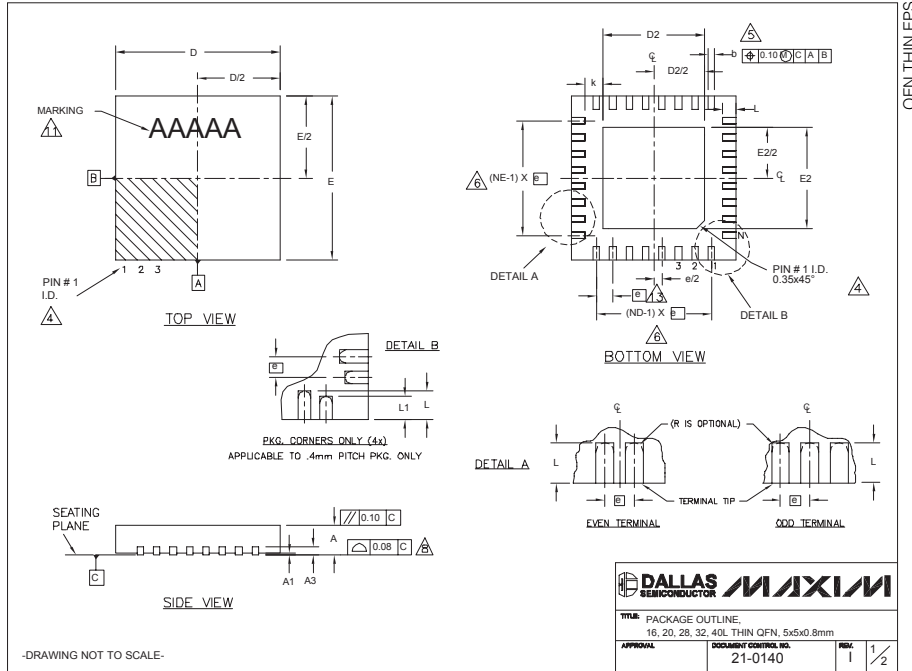

-DRAWING NOT TO SCALE-

COMMON DIMENSIONS												
PKG. SYMBOL	16L 5x5		20L 5x5		28L 5x5		32L 5x5		40L 5x5			
	MIN	NOM	MAX	MIN	NOM	MAX	MIN	NOM	MAX	MIN	NOM	MAX
A	0.70	0.75	0.80	0.70	0.75	0.80	0.70	0.75	0.80	0.70	0.75	0.80
A1	0	0.02	0.05	0	0.02	0.05	0	0.02	0.05	0	0.02	0.05
A3	0.20 REF.		0.20 REF.		0.20 REF.		0.20 REF.		0.20 REF.		0.20 REF.	
b	0.25	0.30	0.35	0.25	0.30	0.35	0.20	0.25	0.30	0.20	0.25	0.30
D	4.90	5.00	5.10	4.90	5.00	5.10	4.90	5.00	5.10	4.90	5.00	5.10
E	4.90	5.00	5.10	4.90	5.00	5.10	4.90	5.00	5.10	4.90	5.00	5.10
e	0.80 BSC.		0.65 BSC.		0.50 BSC.		0.50 BSC.		0.40 BSC.			
k	0.25	-	-	0.25	-	-	0.25	-	-	0.25	0.35	0.45
L	0.30	0.40	0.50	0.45	0.55	0.65	0.45	0.55	0.65	0.30	0.40	0.50
L1	-	-	-	-	-	-	-	-	-	-	0.30	0.40
N	16		20		28		32		40			
ND	4		5		7		8		10			
NE	4		5		7		8		10			
JEDEC	WHHB		WHHC		WHHD-1		WHHD-2		-----			

EXPOSED PAD VARIATIONS												
PKG. CODES	D2			E2			L	DOWN BONDS ALLOWED				
	MIN	NOM	MAX	MIN	NOM	MAX			±0.15			
T1655-2	3.00	3.10	3.20	3.00	3.10	3.20	**	YES				
T1655-3	3.00	3.10	3.20	3.00	3.10	3.20	**	NO				
T1655N-1	3.00	3.10	3.20	3.00	3.10	3.20	**	NO				
T2055-3	3.00	3.10	3.20	3.00	3.10	3.20	**	YES				
T2055-4	3.00	3.10	3.20	3.00	3.10	3.20	**	NO				
T2055-5	3.15	3.25	3.35	3.15	3.25	3.35	0.40	YES				
T2855-3	3.15	3.25	3.35	3.15	3.25	3.35	**	YES				
T2855-4	2.60	2.70	2.80	2.60	2.70	2.80	**	YES				
T2855-5	2.60	2.70	2.80	2.60	2.70	2.80	**	NO				
T2855-6	3.15	3.25	3.35	3.15	3.25	3.35	**	NO				
T2855-7	2.60	2.70	2.80	2.60	2.70	2.80	**	YES				
T2855-8	3.15	3.25	3.35	3.15	3.25	3.35	0.40	YES				
T2855N-1	3.15	3.25	3.35	3.15	3.25	3.35	**	NO				
T3255-3	3.00	3.10	3.20	3.00	3.10	3.20	**	YES				
T3255-4	3.00	3.10	3.20	3.00	3.10	3.20	**	NO				
T3255-5	3.00	3.10	3.20	3.00	3.10	3.20	**	YES				
T3255N-1	3.00	3.10	3.20	3.00	3.10	3.20	**	NO				
T4055-1	3.20	3.30	3.40	3.20	3.30	3.40	**	YES				

**SEE COMMON DIMENSIONS TABLE

DALLAS SEMICONDUCTOR	MAXIM
TITLE: PACKAGE OUTLINE, 16, 20, 28, 32, 40L THIN QFN, 5x5x0.8mm	
APPROVAL:	DOCUMENT CONTROL NO: 21-0140
	REV: 1 1/2

-DRAWING NOT TO SCALE-

-DRAWING NOT TO SCALE-

- NOTES:
- DIMENSIONING & TOLERANCING CONFORM TO ASME Y14.5M-1994.
 - ALL DIMENSIONS ARE IN MILLIMETERS. ANGLES ARE IN DEGREES.
 - N IS THE TOTAL NUMBER OF TERMINALS.
 - THE TERMINAL #1 IDENTIFIER AND TERMINAL NUMBERING CONVENTION SHALL CONFORM TO JEDEC 95-1 SPP-012. DETAILS OF TERMINAL #1 IDENTIFIER ARE OPTIONAL, BUT MUST BE LOCATED WITHIN THE ZONE INDICATED. THE TERMINAL #1 IDENTIFIER MAY BE EITHER A MOLD OR MARKED FEATURE.
 - DIMENSION b APPLIES TO METALLIZED TERMINAL AND IS MEASURED BETWEEN 0.25 mm AND 0.30 mm FROM TERMINAL TIP.
 - ND AND NE REFER TO THE NUMBER OF TERMINALS ON EACH D AND E SIDE RESPECTIVELY.
 - DEPOPULATION IS POSSIBLE IN A SYMMETRICAL FASHION.
 - COPLANARITY APPLIES TO THE EXPOSED HEAT SINK SLUG AS WELL AS THE TERMINALS.
 - DRAWING CONFORMS TO JEDEC MO220, EXCEPT EXPOSED PAD DIMENSION FOR T2855-3 AND T2855-6.
 - WARPAGE SHALL NOT EXCEED 0.10 mm.
 - MARKING IS FOR PACKAGE ORIENTATION REFERENCE ONLY.
 - NUMBER OF LEADS SHOWN ARE FOR REFERENCE ONLY.
 - LEAD CENTERLINES TO BE AT TRUE POSITION AS DEFINED BY BASIC DIMENSION "e", ±0.05.

USB Peripheral/Host Controller with SPI Interface

Package Information (continued)

(The package drawing(s) in this data sheet may not reflect the most current specifications. For the latest package outline information go to www.maxim-ic.com/packages.)

MAX3421E

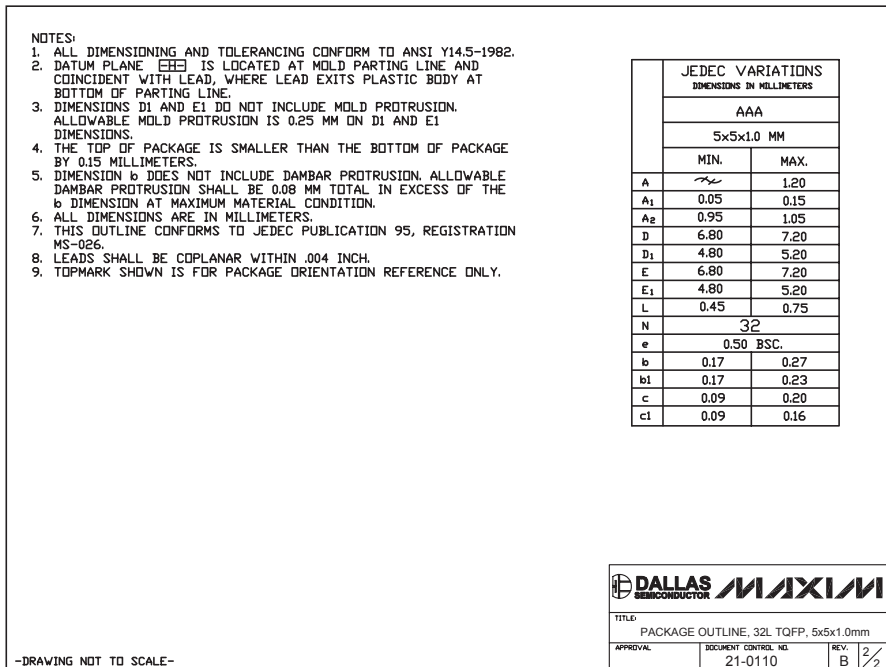
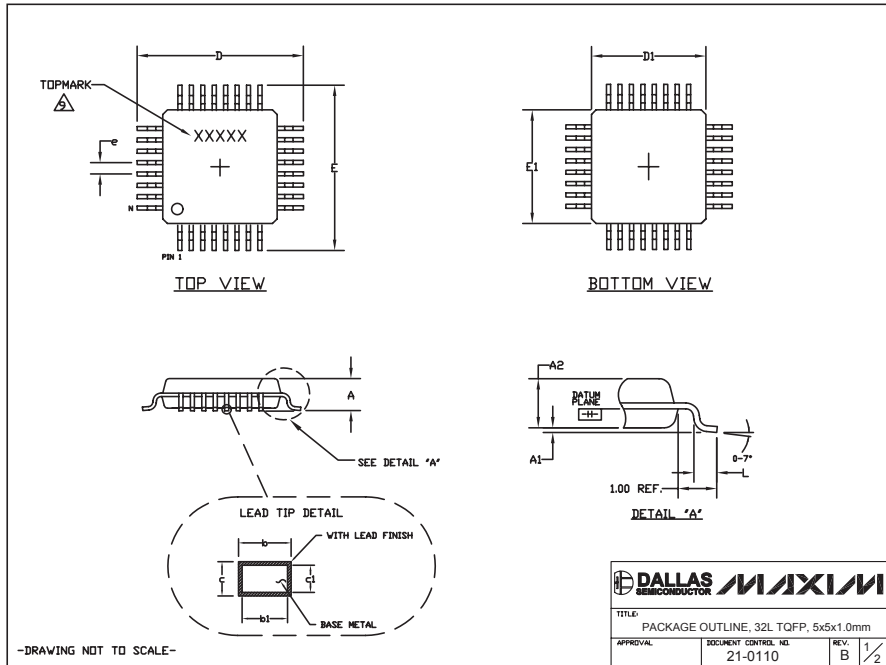

Maxim cannot assume responsibility for use of any circuitry other than circuitry entirely embodied in a Maxim product. No circuit patent licenses are implied. Maxim reserves the right to change the circuitry and specifications without notice at any time.

Maxim Integrated Products, 120 San Gabriel Drive, Sunnyvale, CA 94086 408-737-7600 _____ **29**