

1,024-Bit Serial Electrically Erasable PROM with 2V Read Capability

FEATURES

- **State-of-the-Art Architecture**
 - Nonvolatile data storage
 - Single supply - 5V operation
 - Fully TTL compatible inputs and outputs
 - Auto increment for efficient data dump
 - 1MHz operation
- **Hardware and Software Write Protection**
 - Defaults to write-disabled state at power up
 - Software instructions for write-enable/disable
 - V_{cc} lockout inadvertent write protection
- **Low Power Consumption**
 - 1mA active (typical)
 - 1µA standby (typical)
- **Low Voltage Read Operations**
 - Reliable read operations down to 2.0 volts
- **Advanced Low Voltage CMOS E²PROM Technology**
- **Versatile, Easy-to-Use Interface**
 - Self-timed programming cycle
 - Automatic erase-before-write
 - Programming Status Indicator
 - Word and chip erasable
- **Durable and Reliable**
 - 10-year data retention after 100K write cycles
 - Minimum of 100,000 write cycles per word
 - Unlimited read cycles
 - ESD protection

PIN CONFIGURATIONS

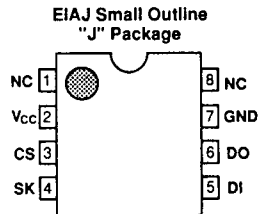
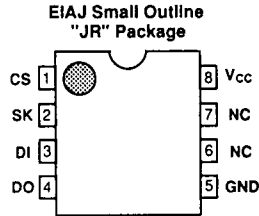
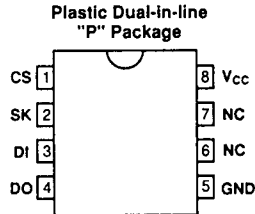

SERIAL
2
P UCTS

OVERVIEW

The XL93LC46 is a low cost 1,024-bit, nonvolatile, serial E²PROM. It is fabricated using EXEL's advanced CMOS E²PROM technology. The XL93LC46 provides efficient nonvolatile read/write memory arranged as 64 registers of 16 bits each. Seven 9-bit instructions control the operation of the device, which include read, write, and mode enable functions. The data output pin (DO) indicates the status of the device during the self-timed nonvolatile programming cycle.

PIN NAMES

CS	Chip Select
SK	Serial Data Clock
DI	Serial Data Input
DO	Serial Data Output
GND	Ground
V _{cc}	Power Supply
NC	Not Connected

BLOCK DIAGRAM

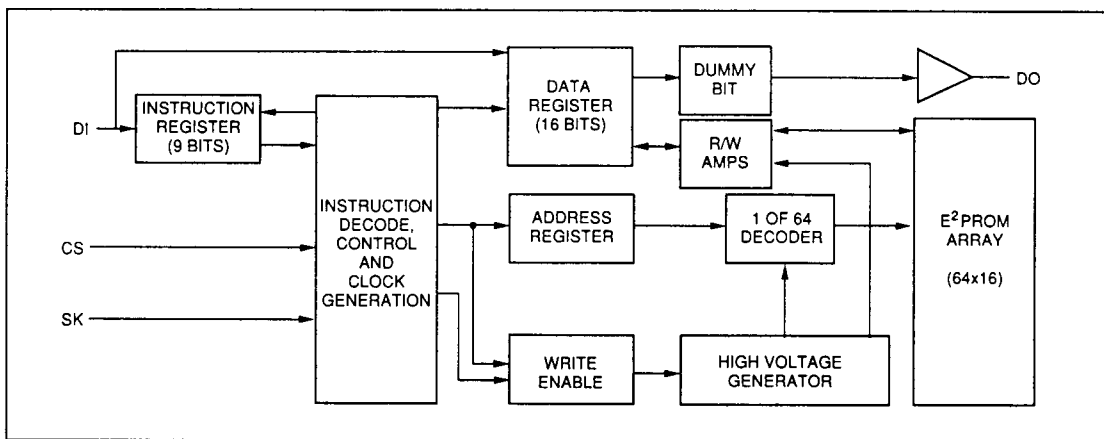

The self-timed write cycle includes an automatic erase-before-write capability. To protect against inadvertent writes, the WRITE instruction is accepted only while the chip is in the write enabled state. Data is written in 16 bits per write instruction into the selected register. If Chip Select (CS) is brought HIGH after initiation of the write cycle, the Data Output (DO) pin will indicate the READY/ $\overline{\text{BUSY}}$ status of the chip.

APPLICATIONS

The XL93LC46 is ideal for high volume applications requiring low power and low density storage. This device uses a low cost, space saving 8-pin package. Candidate applications include robotics, alarm devices, electronic locks, meters and instrumentation settings.

ENDURANCE AND DATA RETENTION

The XL93LC46 is designed for applications requiring up to 100,000 write cycles per bit. It provides 10 years of secure data retention without power after the execution of 100,000 write cycles for each location.

DEVICE OPERATION

The XL93LC46 is controlled by seven 9-bit instructions. Instructions are clocked in (serially) on the DI pin. Each instruction begins with a logical "1" (the start bit). This is followed by the opcode (2 bits), the address field (6 bits), and data, if appropriate. The clock signal (SK) may be halted at any time and the XL93LC46 will remain in its last state. This allows full static flexibility and maximum power conservation.

Read (READ)

The READ instruction is the only instruction that results in serial data on the DO pin. After the read instruction and address have been decoded, data is transferred from the selected memory register into a 16-bit serial shift register. (Please note that one logical "0" bit precedes the actual 16-bit output data string.) The output on DO changes during the low-to-high transitions of SK. (See Figure 3.)

Low Voltage Read

The XL93LC46 has been designed to ensure that data read operations are reliable in low voltage environments. The XL93LC46 is guaranteed to provide accurate data during read operations with V_{CC} as low as 2.0V. (Note: When V_{CC} falls below 4.5 volts, the maximum clock frequency is reduced to 250kHz.)

Auto Increment Read Operations

In the interest of memory transfer operation applications, the XL93LC46 has been designed to output a continuous stream of memory content in response to a single read operation instruction. To utilize this function, the system asserts a read instruction specifying a start location address. Once the 16 bits of the addressed word have been clocked out, the data in consecutively higher address locations is output until the top of the array is reached at which point the memory pointer rolls over to the bottom of the array. The address will wrap around with CS HIGH until the Chip Select control pin is brought LOW. This allows for single instruction data dumps to be executed with a minimum of firmware overhead.

Write Enable (WEN)

The write enable (WEN) instruction must be executed before any device programming can be done. When V_{CC} is applied, this device powers up in the write disabled state. The device then remains in a write disabled state.

until a WEN instruction is executed. Thereafter the device remains enabled until a WDS instruction is executed or until V_{CC} is removed. (NOTE: Neither the WEN nor the WDS instruction has any effect on the READ instruction.) (See Figure 4.)

Write (WRITE)

The WRITE instruction includes 16 bits of data to be written into the specified register. After the last data bit has been clocked into DI, and before the next rising edge of SK, CS must be brought LOW. The falling edge of CS initiates the self-timed programming cycle.

After a minimum wait of 250ns from the falling edge of CS (t_{cs}), if CS is brought HIGH, DO will indicate the READY/BUSY status of the chip: logical "0" means programming is still in progress; logical "1" means the selected register has been written, and the part is ready for another instruction. (See Figure 5.) (NOTE: The combination of CS HIGH, DI HIGH and the rising edge of the SK clock, resets the READY/BUSY flag. Therefore, it is important if you want to access the READY/BUSY flag, not to reset it through this combination of control signals.) Before a WRITE instruction can be executed, the device must be write enabled (see WEN).

Write All (WRALL)

The write all (WRALL) instruction programs all registers with the data pattern specified in the instruction.

As with the WRITE instruction, if CS is brought HIGH after a minimum wait of 250ns (t_{cs}), the DO pin indicates the READY/BUSY status of the chip. (See Figure 6.)

Write Disable (WDS)

The write disable (WDS) instruction disables all programming capabilities. This protects the entire memory array against accidental modification of data until a WEN instruction is executed. (When V_{CC} is applied, this part powers up in the write-disabled state.) To protect data, a WDS instruction should be executed upon completion of each programming operation. (NOTE: Neither the WEN nor the WDS instruction has any effect on the READ instruction.) (See Figure 7.)

Erase Register

After the erase instruction is entered, CS must be brought LOW. The falling edge of CS initiates the self-timed internal programming cycle. Bringing CS HIGH after a minimum of t_{cs}, will cause DO to indicate the READY/BUSY status of the chip: a logical "0" indicates programming is still in progress; a logical "1" indicates the erase cycle is complete and the part is ready for another instruction. (See Figure 8.)

Erase All (ERAL)

Full chip erase is provided for ease of programming. Erasing the entire chip involves setting all bits in the entire memory array to a logical "1." (See Figure 9.)

V_{CC} Lockout - Inadvertent Write Protection

To ensure against inadvertent write operations, the XL93LC46 has been equipped with an internal V_{CC} sensor circuit which inhibits data alteration when the supply voltage (V_{CC}) falls below V_{WL}. If the applied V_{CC} is below 3.75V (typical), the XL93LC46 is inhibited from executing write operations thereby protecting the non-volatile data from inadvertent write operations.

INSTRUCTION SET

Instruction	Start Bit	OP Code	Address	Input Data
READ	1	10	(A ₅ -A ₀)	
WEN (Write Enable)	1	00	11XXXX	
WRITE	1	01	(A ₅ -A ₀)	D ₁₅ -D ₀
WRALL (Write All Registers)	1	00	01XXXX	D ₁₅ -D ₀
WDS (Write Disable)	1	00	00XXXX	
ERASE	1	11	(A ₅ -A ₀)	
ERAL (Erase All Registers)	1	00	10XXXX	

ABSOLUTE MAXIMUM RATINGS

Temperature under bias: XLS93LC46	0°C to +70°C
XLE93LC46	-40°C to +85°C
Storage Temperature	-65°C to +150°C
Lead Soldering Temperature (less than 10 seconds)	300°C
Supply Voltage	0 to 6.5V
Voltage on Any Pin	-0.3 to Vcc + 0.3V
ESD Rating	2000V

NOTE: These are STRESS ratings only. Appropriate conditions for operating these devices are given elsewhere in this specification. Stresses beyond those listed here may permanently damage the part. Prolonged exposure to maximum ratings may affect device reliability.

DC ELECTRICAL CHARACTERISTICS

TA = 0°C to +70°C for the XLS93LC46 or -40°C to +85°C for the XLE93LC46

Symbol	Parameter	Conditions	Vcc = 5V ± 10%		Vcc=2.0V (Read Only)		Units
			Min	Max	Min	Max	
Icc1	Operating Current CMOS Input Levels	CS = Vcc, SK = 1MHz @ 5V SK = 250KHz @ 2V		2		2	mA
Icc2	Operating Current TTL Input Levels	CS = VIH, SK = 1MHz		5		5	mA
Isb	Standby Current	CS = DI = SK = 0V		2		2	µA
Ili	Input Leakage	VIN = 0V to Vcc, CS, SK, DI	-1	1	-1	1	µA
Ilo	Output Leakage	VOUT = 0V to Vcc, CS = 0V	-1	1	-1	1	µA
VIL	Input Low Voltage		-0.1	0.8	-0.1	0.1 Vcc	V
VIH	Input High Voltage		2	Vcc	0.9 Vcc	Vcc + 0.2	V
VOL1	Output Low Voltage	IOL = 2.1mA TTL		0.4		n/a	V
VOH1	Output High Voltage	IOH = -400µA TTL	2.4		n/a		V
VOL2	Output Low Voltage	IOL = 10µA CMOS		0.2		0.2	V
VOH2	Output High Voltage	IOH = -10µA CMOS	Vcc - 0.2		Vcc - 0.2		V
Vwi	Write Inhibit Threshold		2.7	4.4	n/a	n/a	V

AC ELECTRICAL CHARACTERISTICS

TA = 0°C to +70°C for the XLS93LC46 or -40°C to +85°C for the XLE93LC46

Symbol	Parameter	Conditions	Vcc = 5V ± 10%		Vcc=2.0V (Read Only)		Units
			Min	Max	Min	Max	
fsk	SK Clock Frequency		0	1000	0	250	KHz
tSKH	SK High Time	XLS XLE	250 400		2000 2000		ns ns
tSKL	SK Low Time		250		2000		ns
tCS	Minimum CS Low Time		250		1000		ns
tCSS	CS Setup Time	Relative to SK	50		200		ns
tDIS	DI Setup Time	Relative to SK	100		400		ns
tCSH	CS Hold Time	Relative to SK	0		0		ns
tDIH	DI Hold Time	Relative to SK	100		400		ns
tPD1	Output Delay to "1"	AC Test		500		2000	ns
tPD0	Output Delay to "0"	AC Test		500		2000	ns
tSV	CS to Status Valid	AC Test CL = 100pF		500		2000	ns
tDF	CS to DO in 3-state	CS = Low to DO = Hi-Z		100		400	ns
tWP	Write Cycle Time	CS = Low to DO = Ready		10	n/a	n/a	ms

CAPACITANCE

TA = 25°C, f = 250KHz

Symbol	Parameter	Max	Units
CIN	Input Capacitance	5	pF
COU	Output Capacitance	5	pF

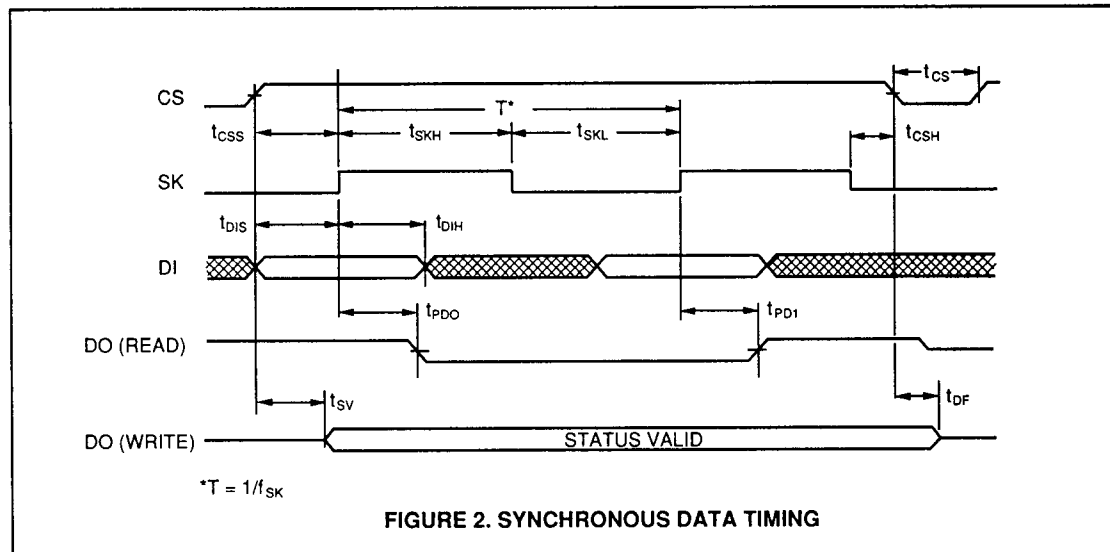
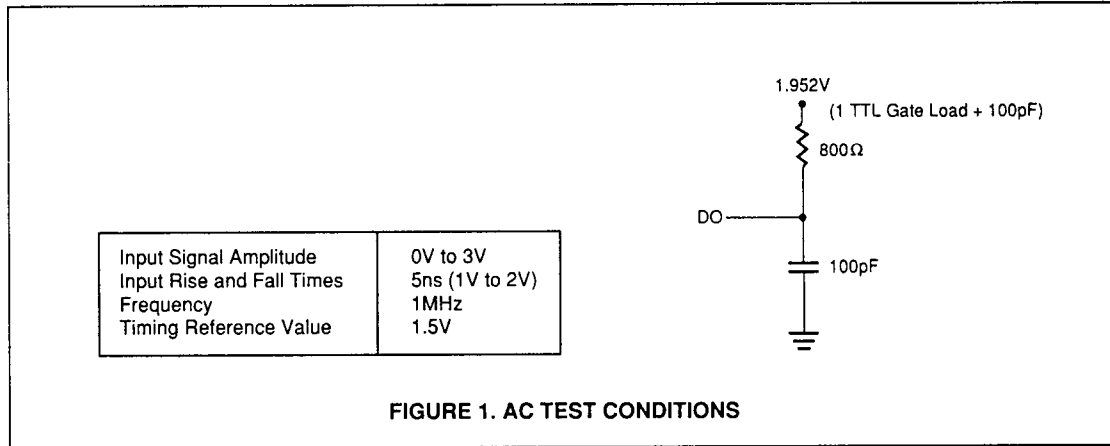

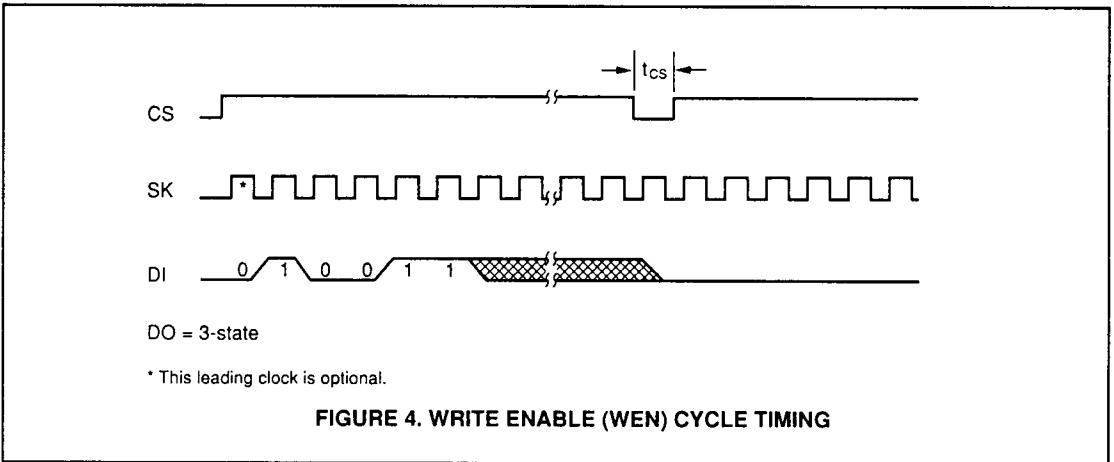
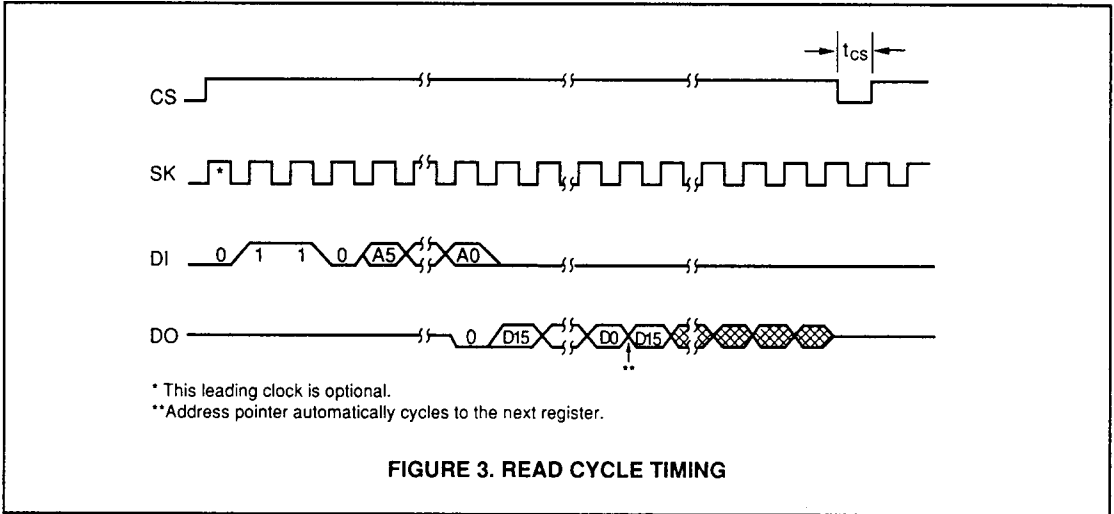

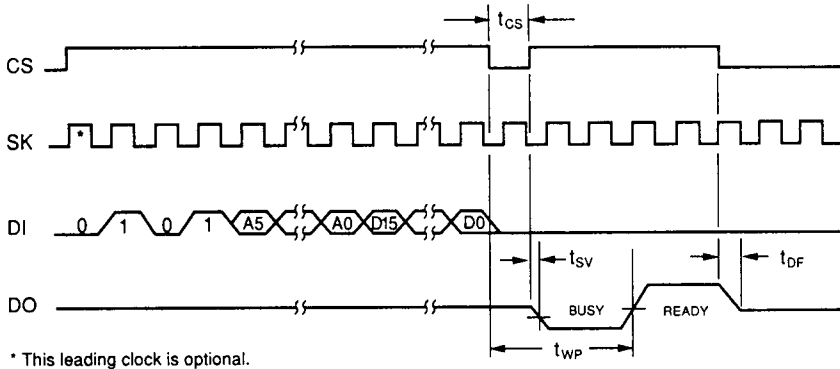

FIGURE 5. WRITE CYCLE TIMING

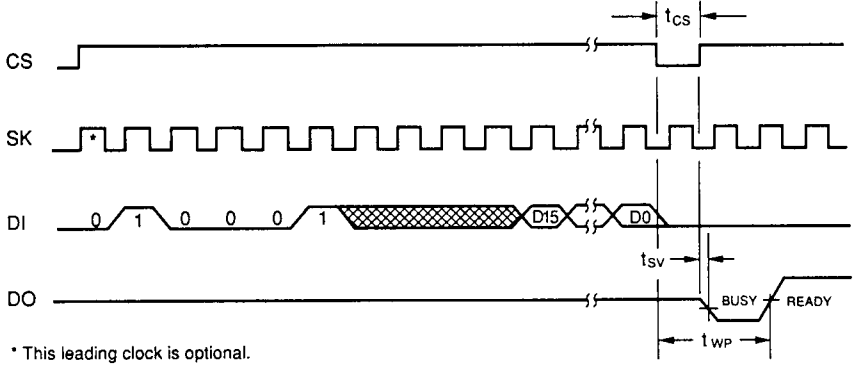
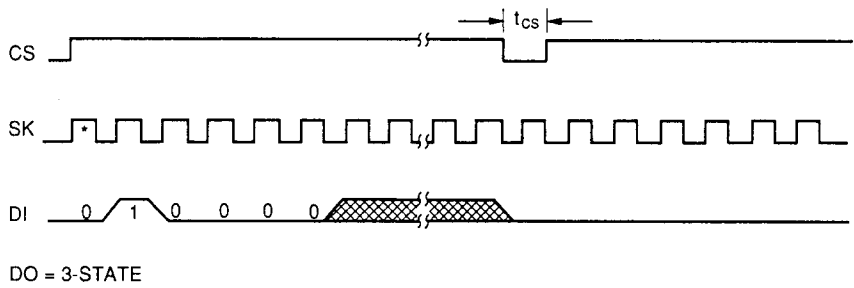
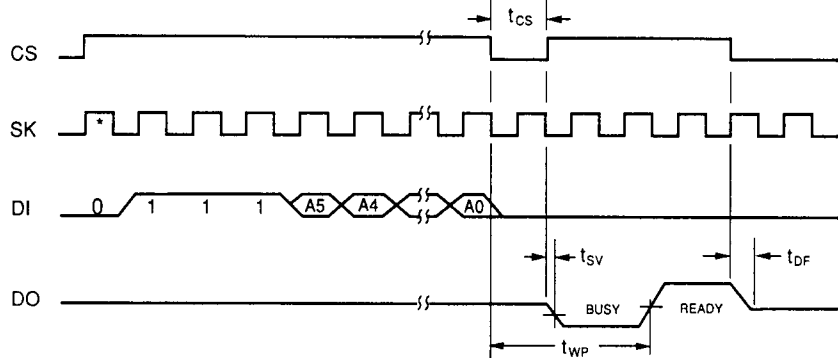

FIGURE 6. WRITE ALL (WRALL) CYCLE TIMING



* This leading clock is optional.

FIGURE 7. WRITE DISABLE (WDS) CYCLE TIMING



* This leading clock is optional.

FIGURE 8. ERASE (REGISTER) CYCLE TIMING

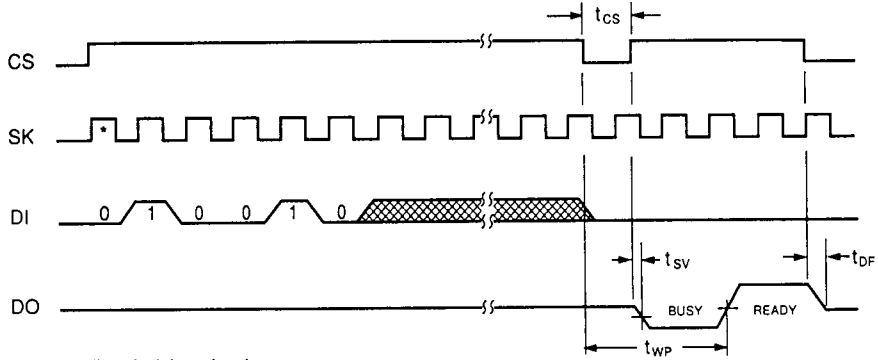

FIGURE 9. ERASE ALL (ERAL) CYCLE TIMING