

Distributed by:

JAMECO[®]
ELECTRONICS

www.Jameco.com ♦ 1-800-831-4242

The content and copyrights of the attached
material are the property of its owner.

Step Angle: 1.8°
Insulation resistance: 500Vdc 100M ohms min.
No. of phase: 4
Voltage: 12V
Current: 400mA
Resistance: 30 ohms
Inductance: 23mH
Holding torque: 2000 g.cm
Detent torque: <220 g.cm
Leads: 26AWG UL 1007

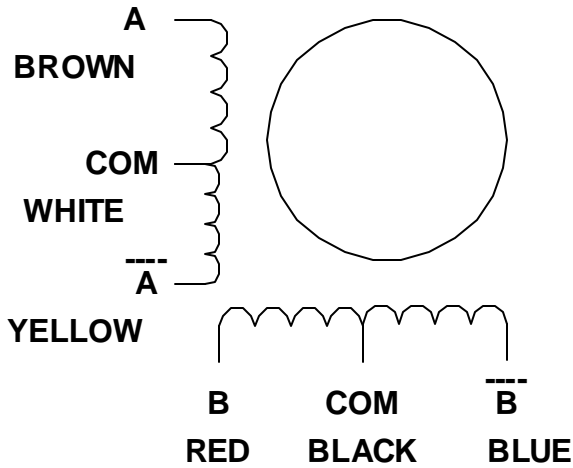
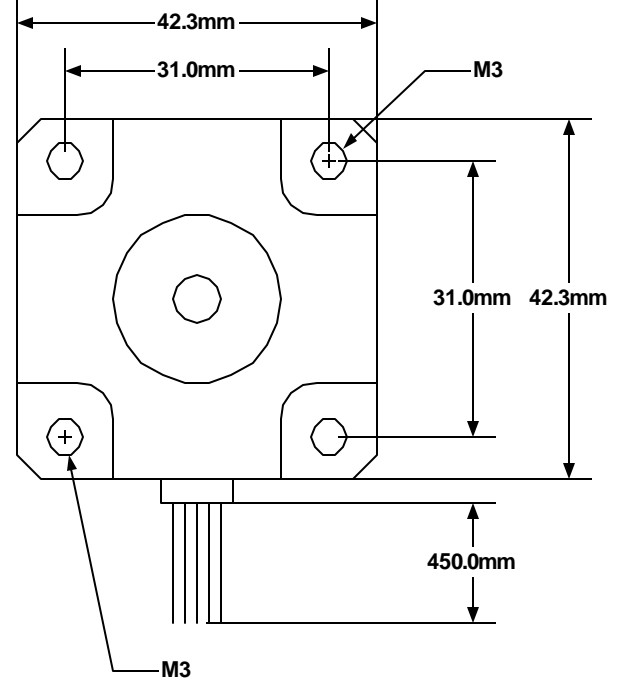
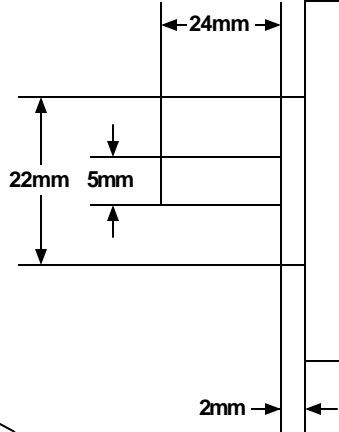

PM Stepper Motor

Jameco Part Number 155432

SIZE mm	FSCM NO	DWG NO 42BYG228	REV
SCALE	SHEET		1 OF 1