

Stamp Applications no. 14 (April '96):

When You Feel that Need for Speed: Hotter Hardware and Swifter Software

Accelerating and Compiling PBASIC
And More Boolean Logic,
by Scott Edwards

THE STAMPS are no speed demons. Fortunately, in most of the control-oriented applications for which the Stamps are appropriate, speed is not an issue.

But in some cases, speed is critical. In my previous column on rotary encoders (October '95) we discovered that at the BS1's execution rate of 2000 instructions per second (3000 for the BS2), it simply could not keep up with the pulses from a low-resolution rotary encoder turned by hand. The solution was to use faster hardware: a Counterfeit controller (BS1 clone; Sources) accelerated to 8000 instructions per second.

This month, we're going to look at another speed-critical application and see how dramatic acceleration was achieved through changes in *software*. Then we'll look at a brand-new compiler that puts the pedal to the metal by generating assembly-language code from your PBASIC programs. Finally, in our BASIC-for-beginners series, we'll examine PBASIC's Boolean logic operators and summarize their uses in decision-making and bit manipulation.

Scanning LED Display. Almost two years ago, I presented a project called the Picture Stick in *Electronics Now* (Oct. '94). The stick consists of a microcontroller-driven array of 16 LEDs. When you wave the stick through the air, viewers see

a two-dimensional image created by the rapidly changing pattern of lights.

Recently I received e-mail from a high-school instructor, Ralph Wallio of Indianola High School (IHS), who wondered if the project could be adapted to run on a spinning wheel and to display text instead of individual frames of graphics. I told him it could, but the modification would require rewriting the assembly language code for the project—something he'd have to undertake himself. He countered that it ought to be possible to create his spinning text display with a 4x accelerated Counterfeit (BS1 workalike in kit form; Sources). I had my doubts.

I was wrong, having underestimated the ingenuity and stick-to-it-iveness of Mr. Wallio and his students.

Their first try met with my pessimistic expectations, though. The main loop of the program had to look up a series of values representing columns of LEDs that made up a message ("IHS AUDITORIUM CREW" in this case); see figure 1. Here's the code they used:

```
Display:
FOR B3=0 TO 86
  LOOKUP B3,(126,9,9,9,126,...),B4
  PINS=B4
NEXT
```

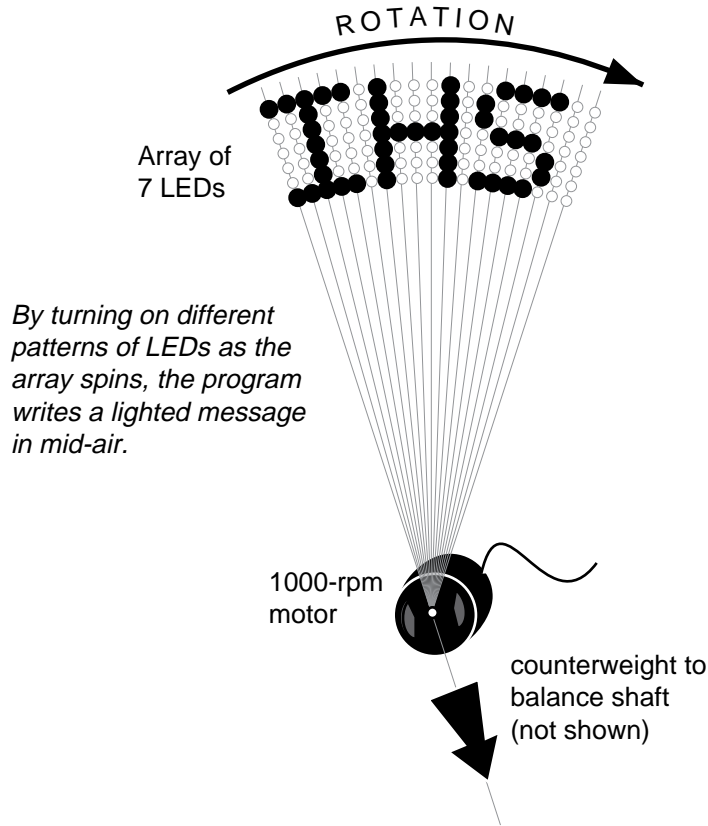

Figure 1. Spinning LED display required a fast program.

Variable B3 was used to pick one of 87 values from a lookup table and store it in B4. Then B4 was copied to the pins of the PBASIC chip. The IHSers measured the execution time of this loop and found it to be 1.18 seconds at PBASIC's normal execution rate.

Their plan was to spin the LED array with a 1000-rpm motor. That's 16.6 revs per second, or about 60 milliseconds (ms) per revolution. The program was about 20 times too slow!

Their ace in the hole was that the Counterfeit can be accelerated 4x by substituting a faster crystal. But the program would still miss the mark by a factor of 5.

My first speedup suggestion was to eliminate the step of copying B4 to PINS. After all, PINS is a byte variable like any other, with the sole exception that its bits protrude into the outside world. I asked the IHS crew to change the Lookup instruction to read:

```
LOOKUP B3,(126,9,9,9,126,...),PINS
```

and recheck the timing. It improved only modestly, to 1.14 seconds.

My next suggestion was more radical. Instead of using the Lookup instruction, why not store the data in EEPROM, and use Read to retrieve it? My thought was that Lookup's extra features (error-detection, 16-bit values) might make it slower than Read. I suggested:

```
EEPROM 0,(126,9,9,9,126...)
Display:
FOR B3=0 TO 86
  READ B3,PINS
NEXT
```

Paydirt! Timing improved to 0.160 seconds. With the Counterfeit's 4x hardware speedup this would drop to 40 milliseconds, meeting the

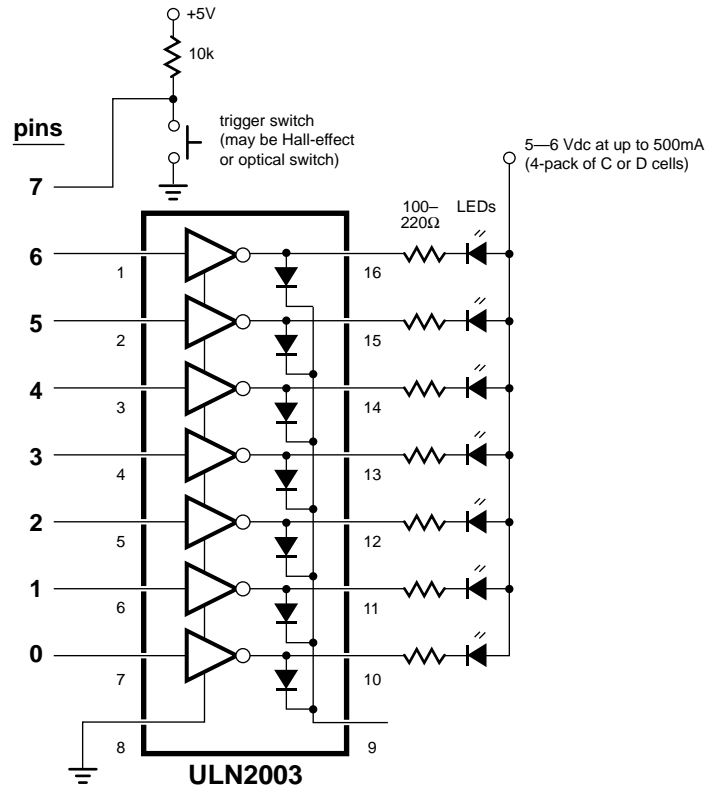

Figure 2. Schematic of the scanning LED display.

60-ms requirement.

There are two lessons here. One is the specific news that Read is dramatically faster than Lookup. If you don't need Lookup's special features, use Read. The other lesson is more general: If you're not getting the performance you need from a program, the answer may lie in changing your approach, rather than just fiddling with the existing code.

Listing 1 is the finished program with the EEPROM data pared down to just the first three letters of the message, "IHS," in the interest of space. Figure 2 is the schematic. The purpose of the trigger switch is to ensure that the LED message always started at the same point in the rotation of the array. This made the message stable through successive spins of the array; just like horizontal sync in a TV.

PBASIC Compiler. OK, so you can speed up BASIC programs by increasing clock rate and streamlining algorithms. What if you *still* need

more speed? Until very recently, your only choice was to rewrite your code in assembly language and program a microcontroller directly. This is a bit more involved than working with the Stamps or Counterfeit, because you need hardware to burn the code into the chip, and gizmos like simulator software or emulator hardware to get your program debugged.

Now there's a shortcut to assembly-language program efficiency. Micro Engineering Labs (Sources) sent me a prerelease sample of a PBASIC compiler, introductory priced at \$99. This is software that runs on a PC and converts PBASIC programs into assembly language. Included software turns the assembly-language code into an object file ready for programming into a PIC16C84 (or other PIC16Cxx micro). You need a PIC programmer to burn the object code into a PIC, but Micro Engineering sells those, too, starting at under \$100, depending on the options you select.

Compiled code is rarely as efficient as code

written by a crafty assembly-language programmer, but it beats the pants off interpreted code. The Stamps are interpreters—they store symbols representing your BASIC program in an EEPROM. When your program runs, the PBASIC controllers reads those symbols, called tokens, one at a time. PBASIC “interprets” their meanings, and performs the required actions.

All this reading and interpreting takes time. In fact, just reading the tokens out of the EEPROM is the single worst bottleneck in the process. This is where the compiled code that’s burned directly into the PIC processor has a tremendous advantage; reading internal program memory is many times faster than reading external EEPROM.

As an example, let’s look at the relative execution rate of the BS1, BS2, 4x Turbo Counterfeit, and compiled code running on a PIC 16C84 at 4 MHz. Here’s the code we’ll use as a benchmark:

```
again:
  b1 = b1 + 1   ' increment b1.
  toggle 0     ' toggle pin 0.
  goto again   ' repeat endlessly.
```

To determine how fast this code ran, I connected a frequency counter to pin 0 of the micro being tested. The higher the frequency, the faster the micro. Here are the results:

BS1, 4 MHz	479 Hz
Counterfeit, 4 MHz	479 Hz
BS2, 20 MHz	689 Hz
Counterfeit, 16 MHz	1917 Hz
16C84, compiled, 4 MHz	7215 Hz

Compiled code running on a 16C84 runs 15 times as fast as the default BS1, and 10.5 times the speed of a BS2.

Another advantage of the compiler is larger program size, depending on the number of instructions used. For example, my DS1620 demo code, presented here in April '95, occupied about 90% of a Stamp’s program memory. Compiled, it took just 613 of the PIC 16C84’s available 1024 instruction words of program

memory.

A common worry with compilers is compatibility; will compiled code behave the same as the original? I tested half a dozen PBASIC programs of moderate to high complexity, and could find no compatibility problems. The compiler documentation does warn that some adjustments to the timing of PBASIC programs may be required to cope with the blistering speed of the compiled code.

BASIC for Beginners. The last couple of installments we’ve been looking at decision-making with Boolean logic. We’ve discovered that AND and OR have very precise meanings that can be used to specify the results of IF/THEN instructions under a range of possible conditions.

This time we’re going to expand on those ideas, seeing how logic operators work on bits.

You may have noticed that the terms AND and OR turn up in a couple of places in the PBASIC manual; first in IF/THEN, and again in LET with the math operators. Only the AND and OR used with LET are represented by symbols, not words. Puzzling.

The logic operators listed under IF/THEN alter the outcome of a decision, while those under LET alter the contents of a variable. Same idea; different application. And under the heading LET, our buddies AND and OR are joined by XOR (as well as variations with NOT, which we’ll see later). Let’s take a look at how these operators work on bits, starting with AND.

AND (symbol: &)

first bit	second bit	result
0	0	0
0	1	0
1	0	0
1	1	1

You can test the correctness of this list, called a “truth table,” by writing a little PBASIC program:

```
let bit0 = 0
let bit1 = 1
let bit2 = bit0 & bit 1
debug bit2: end
```

Try running the program several times with different combinations of bit0 and bit1 until you've convinced yourself of the *truth* of the truth table.

Here are truth tables for the other operators:

OR (symbol: |)

first bit	second bit	result
0	0	0
0	1	1
1	0	1
1	1	1

XOR (exclusive OR; symbol: ^)

first bit	second bit	result
0	0	0
0	1	1
1	0	1
1	1	0

Where things really get interesting with the logic operators is when you apply them to groups of bits, like bytes and words. A byte is a clump of eight bits, and PBASIC has 14 byte variables named b0 through b13. In PBASIC, to specify the bits of a byte, you precede the list of 1s and 0s with the symbol %. Using this notation, let's look at the effects of AND, OR, and XOR on some sample data:

```
%00001111 AND %10101010 = %00001010
%00001111 OR %10101010 = %10101111
%00001111 XOR %10101010 = %10100101
```

The logic shown in the truth tables applies to each pair of bits individually. In the AND example, the rightmost pair of bits are 1 and 0, so the resulting bit is 0, just like the truth table shows. The second pair of bits from the right are 1 and 1, so the corresponding bit of the result is 1.

Let's verify this with a PBASIC program:

```
let b0 = %00001111
let b1 = %10101010
let b2 = b0 & b1 ' AND the bytes.
let b3 = b0 | b1 ' OR the bytes.
let b4 = b0 ^ b1 ' XOR the bytes.
debug "AND result: " %b2
```

```
debug "OR result: " %b3
debug "XOR result: " %b4
```

The logic operators are good for more than just mental exercise. Each has a classic application:

AND: The distinctive characteristic of AND is that there's only one way to get a 1 in the result when you AND two values, and that's by having a 1 in that position of both input values. Put another way, wherever there's a 0 bit in one of the input values, that bit in the output is guaranteed to be 0. So programmers say that AND is can *strip* or *mask off* particular bits of a variable.

Look at the example above. The 0s in the lefthand four bits changed those bits to 0s in the result. The 1s in the righthand four bits faithfully copied the bits of the other value (1010) to the result.

OR: Where AND can clear selected bits to 0, OR has the ability to set selected bits to 1. OR's truth table shows that if either or both bits contain 1, the outcome will be 1. You can see this effect in the example above.

XOR: This is an interesting operator. The XOR of two bits is 1 if one or the other (but not both) input bits is 1. One way to look at this is that XOR allows you to selectively invert particular bits—anywhere one value contains a 1, the result will be the opposite of the other bit. 1 XOR 1 = 0; 1 XOR 0 = 1. Any bit XORED with 0 is unchanged.

Another way of looking at XOR is as a test for matching bit patterns. XORing two identical bytes together yields a byte containing all 0s. XORing two non-identical bytes together yields a byte with 1s in the bit positions at which the two input bytes are different. Very handy.

Variations with NOT. I mentioned that each of the logic operators in PBASIC has a variation with NOT; AND NOT, OR NOT and XOR NOT, symbolized &/, |/, and ^/. The truth tables for these guys are the same as shown above, but with the result bits inverted (1 replaced by 0 and 0 by 1).

Summary. You've worked hard to understand the logic operators, so here's a reward: a tiny program that creates a marquee-style chase

light. Connect LEDs to the outputs (as shown in the Button listing in the Counterfeit Development System manual) and run the following:

```
let dirs = %11111111
pins = %10101010
again:
  let pins = pins ^ %11111111
  pause 200
goto again
```

The program sets all pins to output (dirs=); turns on every other pin (pins=), then enters a loop marked by "again:" that XORs the pins with byte consisting of all 1s. This has the effect of inverting all of the output bits, creating the marquee-flashing effect. After a 200-millisecond pause, the *again* loop repeats.

Sources

For more information on the BASIC Stamp, contact Parallax Inc., 3805 Atherton Road no. 102, Rocklin, CA 95765; phone 916-624-8333;

fax 916-624-8003; BBS 916-624-7101; e-mail info@parallaxinc.com.

The PBASIC compiler is available from Micro Engineering Labs, Box 7532, Colorado Springs, CO 80933; phone 719-520-5323; fax 719-520-1867.

Send questions, suggestions, or requests for future Stamp Applications to:

Scott Edwards Electronics, PO Box 160, Sierra Vista, AZ 85636-0160; phone 520-459-4802; fax 520-459-0623; e-mail (via Compuserve) at 72037,2612; on the Internet 72037.2612 @compuserve.com. Scott offers Stamp-related products and kits, including:

The Counterfeit controller, a kit alternative to the BASIC Stamp, is \$29. Double- and quad-speed options are \$2 and \$4, respectively. The Counterfeit Development System, required to program Counterfeits is \$69 and includes a 150-page manual, downloading cable kit, Parallax software, and one Counterfeit controller kit.

Visa, Mastercard, and American Express accepted for phone/fax orders. Personal checks and money orders are welcome for mail orders.

Listing. Scanning LED Display

```
' Program: SCANLED.BAS (Scanning LED display developed by Ralph Wallio
' and his crew at Indianola High School)
' This is a partial listing of the scanning LED display program. I've
' shortened it to conserve space, since the majority of the program
' is EEPROM data making up the message "IHS AUDITORIUM CREW." Just
' the portion "IHS" is enough to convey the principle.
```

```
DIRS=%01111111 ' Bit 7 is input for trigger; the rest outputs.
```

```
' LED bit patterns forming the letters IHS.
EEPROM 0,(65,65,127,65,65,0,127,8,8,8,127,0,49,73,73,73,69)
'
'      -----      -----      -----
'              I              H              S
```

```
' Wait until triggered before displaying bit patterns on LEDs.
```

```
Trigger_Loop: BUTTON 7,0,0,0,B2,1,Display
               GOTO Trigger_Loop
```

```
Display: FOR B3=0 TO 16 ' Get data from EEPROM.
          READ B3, PINS ' Copy each EEPROM byte to pins.
          PINS=0       ' Blank the LEDs.
          NEXT         ' Get next byte of data.

          GOTO Trigger_Loop ' Done. Wait for next rotation.
```