

Introduction to Pneumatics
and
Pneumatic Circuit Problems for
FPEF Trainer

John R. Groot
President FPEF

John Naghosian
FPEF Educational Coordinator

John Prisciandaro
Birmingham Covington School
Birmingham, Michigan

Dan Butchko
Derby Middle School
Birmingham, Michigan

Fluid Power Education Foundation

3333 N. Mayfair Road
Suite 101
Milwaukee, WI 53222
Phone: (414) 778-3364 FAX: (414)778-3361
<http://www.fpef.org>

Reference Page



Fluid Power Educational Foundation
<http://www.fpef.org/>



National Fluid Power Association
<http://www.nfpa.com/>



International Fluid Power Society
<http://www.ifps.org/>



Fluid Power Distributors Association
<http://www.fpda.org/>



Parker Hannifin Corporation
<http://www.parker.com/>
<http://www.parker.com/training/>



Clippard Minimatic
<http://www.clippard.com/>

Introduction to Pneumatics

with Circuit Design Problems for the FPEF Trainer

Prepared by:

John Prisciandaro and Dan Butchko, Birmingham Public Schools, Birmingham, Michigan

Sponsored by:

Fluid Power Educational Foundation, 3333 North Mayfair Rd., Milwaukee, WI 53222-3219



This FPEF curriculum is designed to be used in conjunction with a pneumatic trainer capable of demonstrating the principles and circuits outlined in the curriculum. The FPEF website provides links to the manufacturers that have produced and made available a trainer capable of being used with the curriculum. This combination provides a comprehensive and hands-on introduction to Pneumatics and Fluid Power capabilities.:

The **Fluid Power Educational Foundation**, with its members, have designed this training panel and manual to help technical teachers and industrial trainers facilitate a hands-on experience with pneumatics. The FPEF is grateful to its members for their hard work and financial support that has made this effort possible. Special thanks to **John Nagohosian**-Educational Coordinator, **John Groot**-President, and **Paul Gant**-Treasurer, who initiated and guided the project along with their legwork, expertise and resources.

John Prisciandaro and **Dan Butchko**, who prepared this manual, are Engineering Technology teachers in the **Birmingham Public School District**, Birmingham, Michigan. Both John and Dan have been involved in previous FPEF sponsored activities, including teacher training sessions, and developing and presenting unique methods of integrating fluid power applications in science and technology courses.

Clippard Instrument Laboratory, Inc. and **Parker Hannifin Corp.**, who allowed the use of their technical reference manuals and application problems, which provided much of the information in this manual;

Mike Pierno, Engineering Technology department head at **Seaholm High School, Birmingham Public School District**, whose program has been in existence for many years, and has actively participated in numerous FPEF sessions. Mike has been responsible for “turning on” hundreds of students to the fluid power/motion control industry and was recently awarded the honor of *Key School* by the FPEF.

About the FPEF

The FPEF promotes technical education that integrates fluid power. The Foundation is always striving to raise the level of competence of young people entering our industry and improve visibility for fluid power technology. For information regarding teacher training sessions, and other activities of the FPEF, contact:

The Fluid Power Educational Foundation

3333 N. Mayfair Road

Milwaukee, WI 53222-3219

Telephone #414-778-3364 Fax #414-778-3361

www.fpef.org

Pneumatic Transmission of Energy

The reason for using pneumatics, or any other type of energy transmission on a machine, is to perform work. The accomplishment of work requires the application of kinetic energy to a resisting object resulting in the object moving through a distance. In a pneumatic system, energy is stored in a potential state under the form of compressed air. Working energy (kinetic energy and pressure) results in a pneumatic system when the compressed air is allowed to expand. For example, a tank is charged to 100 PSIA with compressed air. When the valve at the tank outlet is opened, the air inside the tank expands until the pressure inside the tank equals the atmospheric pressure. Air expansion takes the form of airflow.

To perform any applicable amount of work then, a device is needed which can supply an air tank with a sufficient amount of air at a desired pressure. This device is positive displacement compressor.

What a Positive Displacement Compressor Consists of

A positive displacement compressor basically consists of a movable member inside a housing. The compressor has a piston for a movable member. The piston is connected to a crankshaft, which is in turn connected to a prime mover (electric motor, internal combustion engine). At inlet and outlet ports, valves allow air to enter and exit the chamber.

How a Positive Displacement Compressor Works

As the crankshaft pulls the piston down, an increasing volume is formed within the housing. This action causes the trapped air in the piston bore to expand, reducing its pressure. When pressure differential becomes high enough, the inlet valve opens, allowing atmospheric air to flow in. With the piston at the bottom of its stroke, inlet valve closes. The piston starts its upward movement to reduce the air volume which consequently increases its pressure and temperature. When pressure differential between the compressor chamber and discharge line is high enough, the discharge valve opens, allowing air to pass into an air receiver tank for storage.

Control of Pneumatic Energy

Working energy transmitted pneumatically must be directed and under complete control at all times. If not under control, useful work will not be done and machinery or machine operators might be harmed. One of the advantages of transmitting energy pneumatically is that energy can be controlled relatively easily by using valves.

Control of Pressure

Pressure in a pneumatic system must be controlled at two points - after the compressor and after the air receiver tank. Control of pressure is required after the compressor as a safety for the system. Control of pressure after an air receiver tank is necessary so that an actuator receives a steady pressure source without wasting energy.

Control of Pressure after A Compressor

In a pneumatic system, energy delivered by a compressor is not generally used immediately, but is stored as potential energy in air receiver tank in the form of compressed air.

In most instances, a compressor is designed into a system so that it operates intermittently. A compressor usually delivers compressed air to a receiver tank until high pressure is reached, then it is shut down. When air pressure in the tank decreases, the compressor cuts in and recharges the tank. Intermittent compressor operation in this manner is a power saving benefit for the system.

A common way of sensing tank pressure and controlling actuation and de-actuation of relatively small (2-15 HP) compressors, is with a pressure switch.

Pressure Switch

System pressure is sensed with a spring-loaded piston within the switch housing. When pressure in the system is at its low level, the spring pushes the piston down. In this position a contact is made causing an electrical signal to turn on the compressor.

As pressure in the receiver tank rises, it forces the piston upward. With system pressure at its high level, the piston breaks the electrical contact shutting down the compressor.

Safety Relief Valve

Maximum pressure developed by a compressor is designed to be regulated by a control system which senses discharge or tank pressure. In case of an emergency, such as the failure of a control system to function properly, a positive displacement compressor system is generally equipped with a safety relief valve.

A safety relief valve is a normally closed valve. The poppet of the safety relief valve is seated on the valve inlet. A spring holds the poppet firmly on its seat. Air cannot pass through the valve until the force of the spring biasing the poppet is overcome.

Air pressure at compressor outlet is sensed directly on the bottom of the poppet. When air pressure is at an undesirably high level, the spring will be compressed, the poppet will move off its seat, and air will exhaust through the valve.

A safety relief valve on a compressor is not intended to operate frequently. A safety relief valve is designed only to be a safety device. Many times safety relief valves are equipped with whistles or horns to alert personnel that something has failed or a problem exists.

Pressure Regulator

In a pneumatic system, energy that will be used by the system and transmitted through the system is stored as potential energy in an air receiver tank in the form of compressed air. A pressure regulator is positioned after a receiver tank and is used to portion out this stored energy to each leg of the circuit.

A pressure regulator is a normally open valve.

With a regulator positioned after a receiver tank, air from the receiver can expand (flow) through the valve to a point downstream. As pressure after the regulator rises, it is sensed in an internal pilot passage leading to the underside of the piston.

This piston has a large surface area exposed to downstream pressure and for this reason is quite sensitive to downstream pressure fluctuations. When downstream pressure nears the preset level, the piston moves upward pulling the poppet toward its seat. The poppet, once it seats, does not allow pressure to continue building downstream. In this way, a constant source of compressed air is made available to an actuator downstream.

Common Types of Cylinders

There are many different cylinder types. The most common are listed below:

Single acting cylinder - a cylinder in which air pressure is applied to the movable element (piston) in only one direction.



Spring return cylinder - a cylinder in which a spring returns the piston assembly.



Ram cylinder - a cylinder in which the movable element is the piston rod.

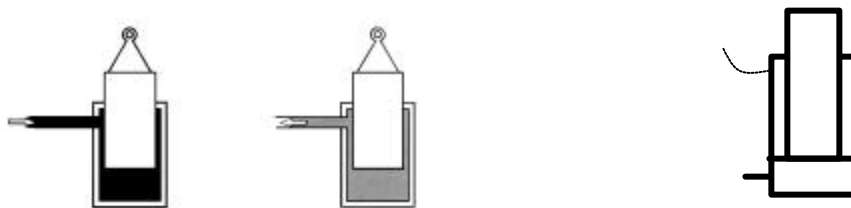

Double acting cylinder - a cylinder in which air pressure may be alternately applied to the piston to drive it in either direction.



Double acting – double rod cylinder - Double acting cylinder with a piston rod extending from each end. The piston rods are connected to the same piston. Double rod cylinders provide equal force and speed in both directions.



Sizing a Cylinder

To determine the size cylinder that is needed for a particular system, certain parameters must be known. First of all, a total evaluation of the load must be made. This total load is not only the basic load that must be moved, but also includes any friction and the force needed to accelerate the load. Also included must be the force needed to exhaust the air from the other end of the cylinder through the attached lines, control valves, etc. Any other force that must be overcome must also be considered as part of the total load. Once the load and required force characteristics are determined, a working pressure should be assumed. This working pressure that is selected **MUST** be the pressure seen at the cylinder's piston when motion is taking place. It is obvious that cylinder's working pressure is less than the actual system pressure due to the flow losses in lines and valves.

With the total load (including friction) and working pressure determined, the cylinder size may be calculated using Pascal's Law. Force is equal to pressure being applied to a particular area. The formula describing this action is:

$$\mathbf{Force = Pressure * Area}$$

Force is proportional to pressure and area. When a cylinder is used to clamp or press, its output force can be computed as follows: $F = P * A$

P = pressure (PSI (Bar) (Pascal's))
 F = force (pounds (Newtons))
 A = area (square inches (square meters))

These pressure, force and area relationships are sometimes illustrated as shown below to aid in remembering the equations.

$$F = P * A$$

$$P = \frac{F}{A}$$

$$A = \frac{F}{P}$$

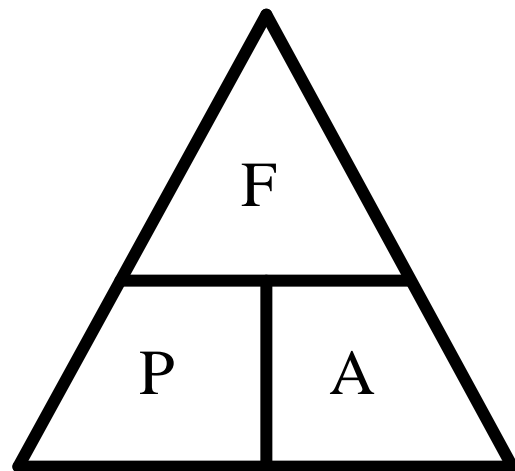

Directional Control Valves

To change the direction of airflow to and from the cylinder, we use a directional control valve. The moving part in a directional control valve will connect and disconnect internal flow passages within the valve body. This action results in a control of airflow direction.

Valve flow diagrams are reprinted courtesy of Parker Hannifin Corporation.

The typical directional control valve consists of a valve body with four internal flow passages within the valve body and a sliding spool.

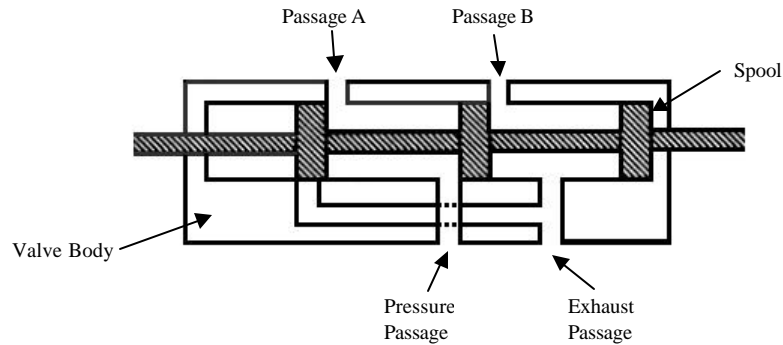

Shifting the spool alternately connects a cylinder port to supply pressure or the exhaust port. With the spool in the position where the supply pressure is connected to port A and port B is connected to the exhaust port, the cylinder will extend. Then, with the spool in the other extreme position, supply pressure is connected to port B and port A is connected to the exhaust port, now the cylinder retracts. With a directional control valve in a circuit, the cylinder's piston rod can be extended or retracted and work performed.

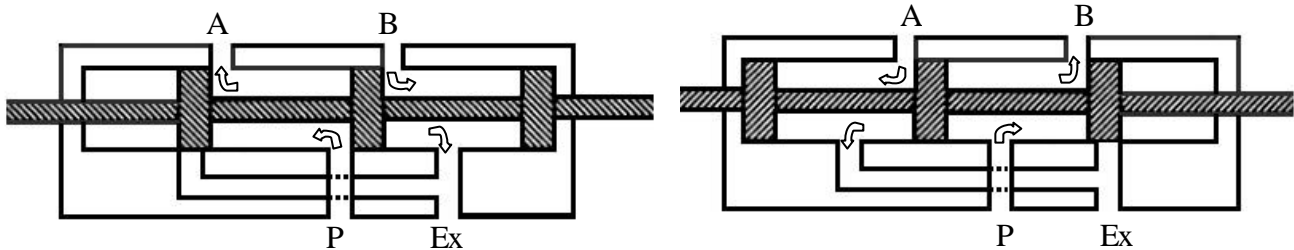

Functional Types of Directional Control Valves

One method of classifying a directional control valve is by the flow paths that are set up in its various operating conditions. Important factors to be considered are the number of individual ports, the number of flow paths the valve is designed for and internal connection of ports with the movable part.

Two-Way Directional Valve

A two-way directional valve consists of two ports connected to each other with passages, which are connected and disconnected. In one extreme spool position, port A is open to port B; the flow path through the valve is open. In the other extreme, the large diameter of the spool closes the path between A and B; the flow path is blocked. A two-way directional valve gives an on-off function.

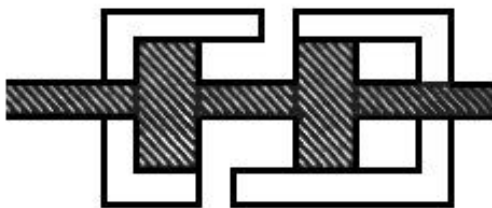

Flow Path Open

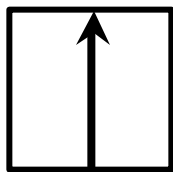

Flow Path Closed

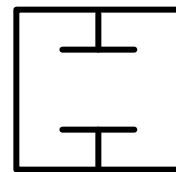

Three-Way Directional Valve

A three-way directional valve consists of three ports connected through passages within a valve body that are shown here as port A, port P and port Ex. If port A is connected to an actuator, port P to a source of pressure and port Ex is open to exhaust, the valve will control the flow of air to (and exhaust from) Port A.

The function of this valve is to pressurize and exhaust one actuator port. When the spool of a three-way valve is in one extreme position, the pressure passage is connected with the actuator passage. When in the other extreme position, the spool connects the actuator passage with the exhaust passage.

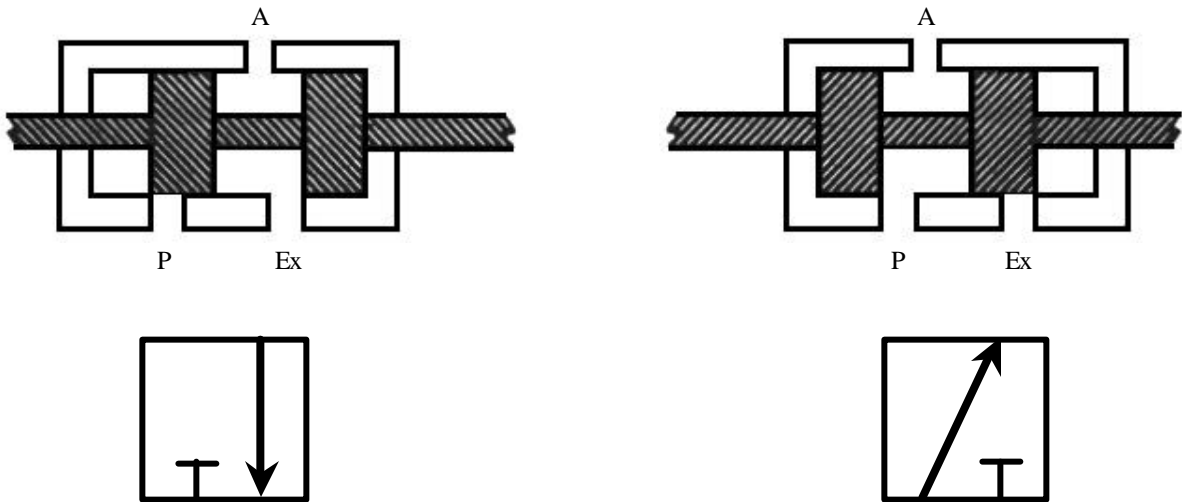

Four-Way Directional Valve

Perhaps the most common directional valve in simple pneumatic systems consists of pressure port, two actuator ports and one or more exhaust ports. These valves are known as four-way valves since they have four distinct flow paths or "ways" within the valve body.

A common application of four-ported four-way directional valve is to cause reversible motion of a cylinder or motor. To perform this function, spool connects the pressure port with one actuator port. At the same time, the spool connects the other actuator port with the exhaust port. This is a four-ported four-way valve.

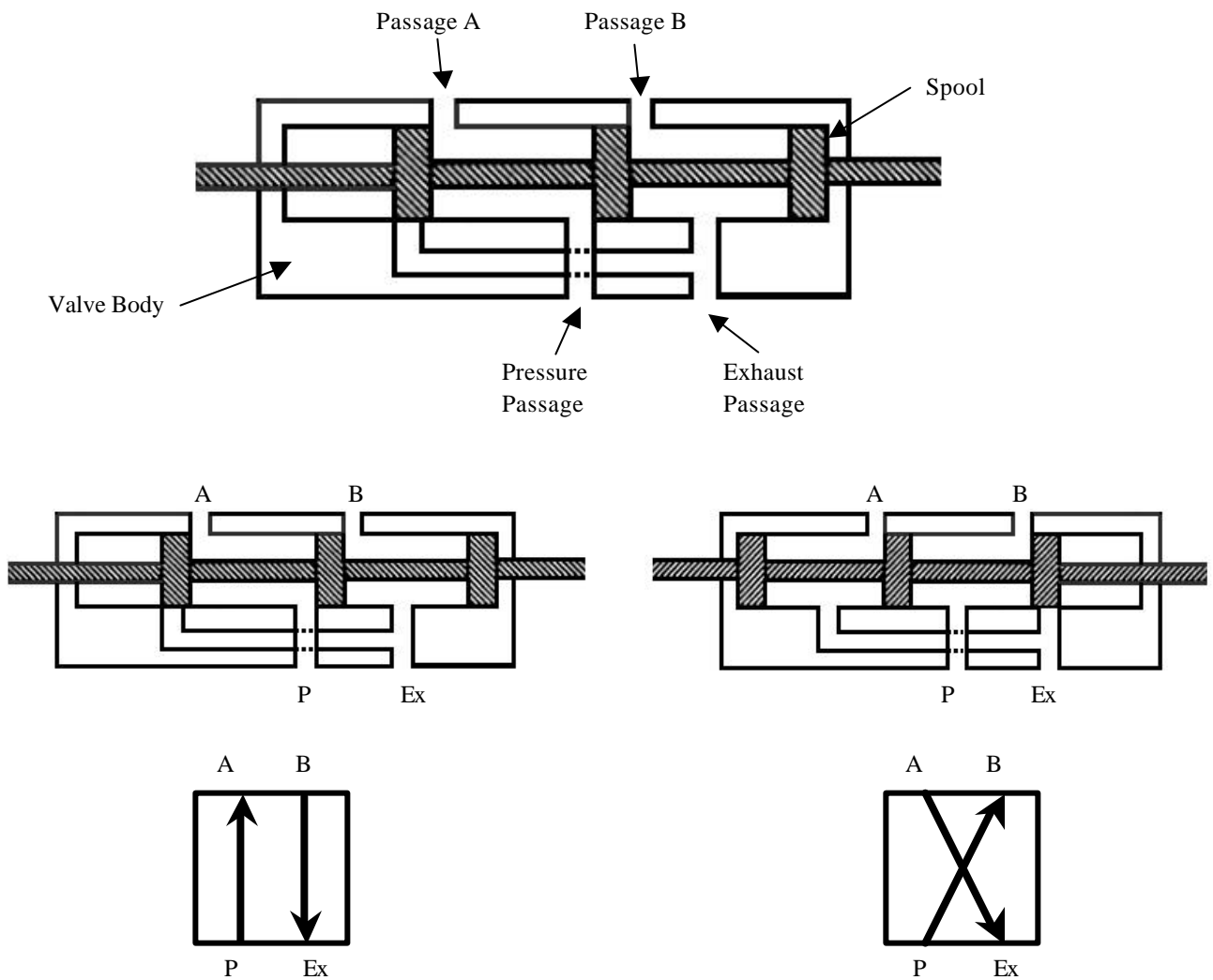

Five-Port / Four-Way Directional Valve

Four-way valves are also available with five external ports, one pressure port, two actuator ports, and two exhaust ports. Such valves provide the same basic control of flow paths as the four-ported version, but have individual exhaust ports. In the fluid power field this is referred to as a "five-ported, four-way valve." This type of valve brings all flow paths to individual external ports. The pressure port is connected to system pressure after a regulator. Actuator ports are connected to inlet and outlet ports of a cylinder or motor. Each exhaust port serves an actuator port.

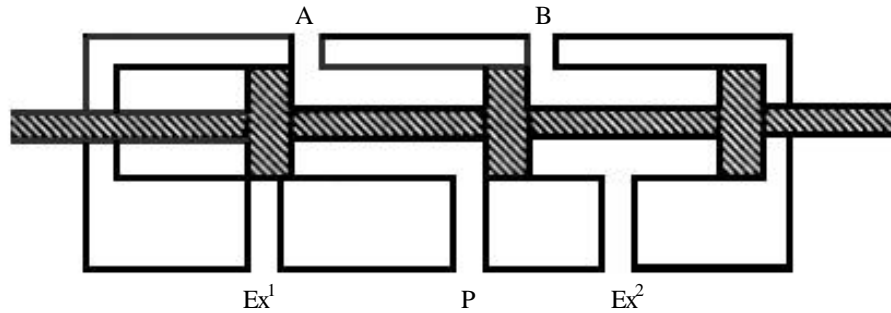

5-Ported, 4-Way Valve

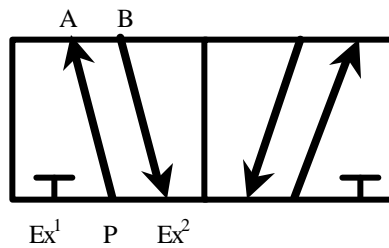

Schematic Symbols for Directional Valves

A directional valve is a valve that directs the flow of air in one with or another. It doesn't throttle or meter the airflow, and it doesn't change the pressure of the air. It just changes the direction of the airflow in some way. The ANSI symbol for directional valves are the most complicated of all the fluid power symbols, but some of the most important, so let us start with directional valves, see how the symbol system works. A typical directional valve symbol is made up of three parts:

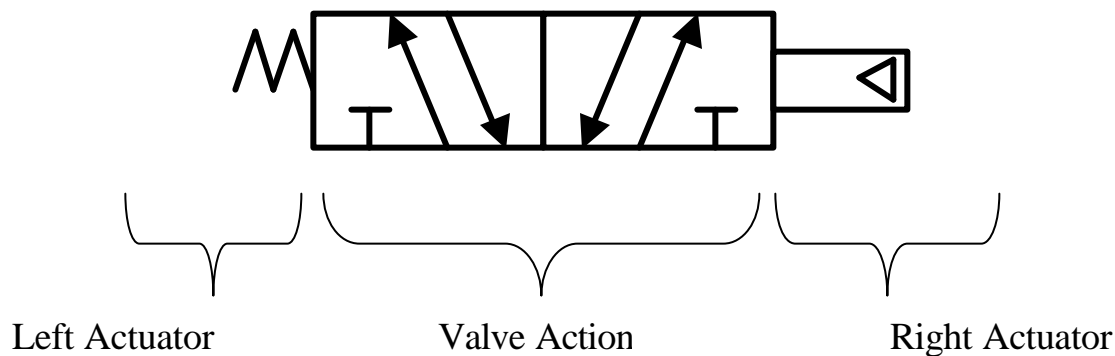

The actuators are the devices or methods that cause the valve to shift from one position to another. The valve action refers to the combinations of positions and flow paths which the valve offers.

Position Boxes

Every valve provides two or more usable positions, each position providing one or more flow paths. For example, the familiar single solenoid spring return valve provides two usable positions, one position occurring when the solenoid is in command of the valve, the other position occurring when the spring is in command of the valve. The ANSI symbol for a directional valve is built around a series of boxes or rectangles, one box for each usable position of the valve.



A 2-Position valve is shown by two boxes.



A 3-Position valve is shown by three boxes.

Most air moves are either 2-position or 3-position valves, but it would be possible to have an unusual valve with four or five or even six positions. In any case, there would be a box to represent each position of the valve.

Valve Ports

Every valve port, which appears on the outside of the valve, is supposed to be shown on the symbol. But the ports are shown on only one of the boxes, the box that represents the flow paths that exist at the start of the machine cycle. Some examples are:

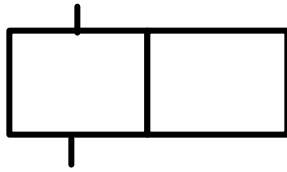

A 2-position 2-port valve

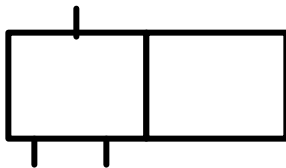

A 2-position 3-port valve

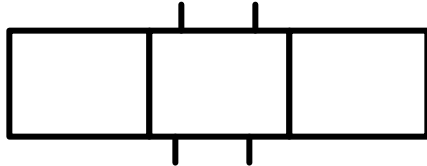

A 3-position 4-port valve

Flow Paths

Each box contains a group of lines that represent the flow paths the valve provides when it is in that position. If a port is blocked, we show that by the symbol **T**. If two ports are connected and air can flow, this is shown by a line drawn between the two ports.

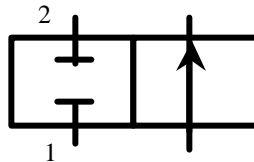

In the example above, the left box shows the conditions that exist at the start of the cycle. Port 1 is blocked, and port 2 is blocked. When the valve is shifted, the flow condition shown in the right hand box exists. Port 1 is open to port 2.

The direction in which air flows *during a normal operating cycle* is shown by putting arrowheads at the ends of the flow paths next to the ports where the air will come out.

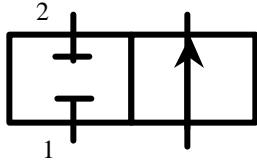

Example #1 - At the start of the cycle, the flow path from port 1 to port 2 is blocked. When the valve shifts, flow is from port 1 to port 2.

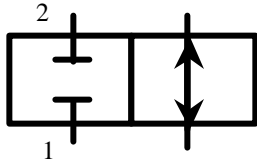

Example #2 - At the start of the cycle, the flow path from port 1 to port 2 is blocked. When the valve shifts, port 1 is opened to port 2, but during some part of the cycle air flows from port 1 to port 2, and during another part of the cycle air flows from port 2 to port 1.

Typical Symbols for Valve Actions

Two- Position Valves

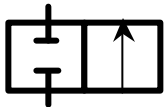

2-Way, Blocked at start of cycle

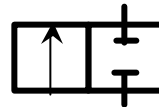

2-Way, Open at start of cycle

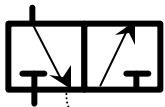

3-Way, Blocked at start of cycle

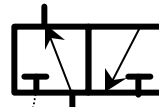

3-Way, Open at start of cycle

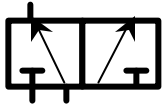

2-Inlet Selector

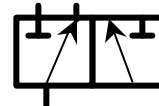

Distributor (Diverter)

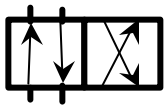

4-Way, 4-port Single Inlet

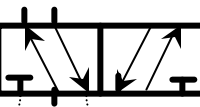

4-Way, 5-Port Single Inlet Dual Exhausts

or

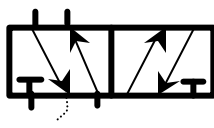

4-Way, 5-port Dual Pressure Common Exhaust

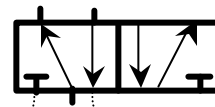

Symbols for Valve Actuators

The symbols for the valve actuators are drawn next to the end of the valve boxes.

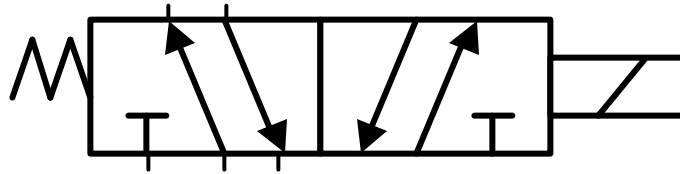

The rule is that each actuator is drawn next to the box that exists when that actuator is in command. In the drawing above, when the spring has control of the valve, the flow paths in the left hand box. When the solenoid (the right hand actuator) is in command, the flow paths in the right hand box exist.

There are a series of standard symbols for actuators. These symbols may be drawn on either end of the valve without altering their meaning.

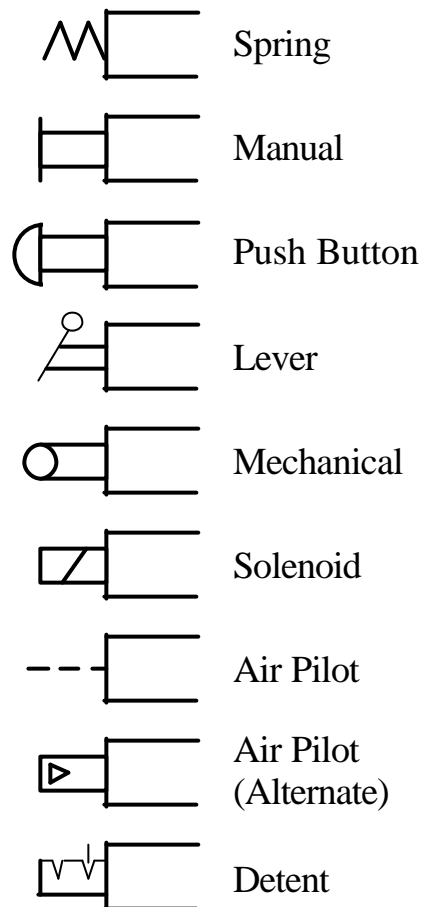

Composite Actuators

If two actuator symbols are drawn side by side, this means that either one can cause the valve to actuate.



Either the air pilot OR the spring can cause the valve to move.

Typical Actuator Combinations



2-Position, Double pilot, detented



3-Position, Double pilot, spring centered

Miscellaneous Valve Symbols

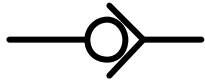

Check Valve - Allows flow in one direction, but blocks flow in the other direction. In this example flow can go from right to left, but now flow left to right is blocked.



Fixed Restriction or orifice - Restricts flow in both directions.



Adjustable Restriction - Restricts flow in both directions.

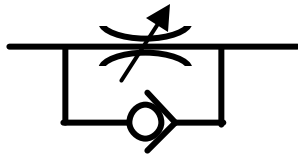

Flow Control Valve - (also called speed control valve) allows free flow in one direction but restricts flow in the other direction. In this example free flow is from right to left, restricted flow from left to right.

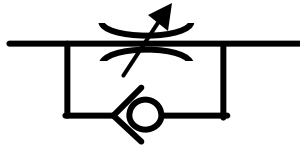

In this example, free flow is from left to right. Restricted flow is from right to left.

Shuttle Valve -

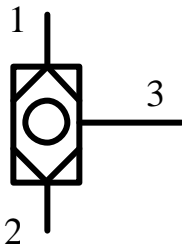

A three-port valve with two inlets and one outlet. In this example ports 1 and 2 are inlets, port 3 the outlet. If pressure is applied to port 1, it will appear out port 3, but will not back-flow out port 2.

If pressure is applied to port 2, it will appear out port 3 but will not back-flow out port 1.

When the pressures are removed from ports 1 and 2, port 3 will exhaust back out one of the two inlet ports, but it may exhaust out either of them.

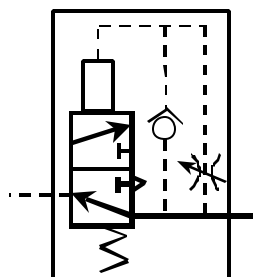

Pulse Valve

A valve that allows the initial supply of air it receives to pass through it just for a few milliseconds (pulse), then remains closed until the supply pressure is exhausted.

Summary Explanation of Valve Terminology

- TWO** Way Valve, Normally Closed:
Flow is from inlet to outlet when the valve is actuated.
Fluid in outlet line is trapped when the valve is deactivated.
- THREE** Way Valve, Normally Closed:
Flow is from inlet to outlet when the valve is actuated.
On deactivation of valve, outlet line is vented to atmosphere.
- THREE** Way Valve, Normally Open:
Flow is from inlet to outlet in the deactivated valve condition.
Actuation of the valve stops flow from inlet to outlet, the outlet is then exhausted.
- FOUR** Way Valve:
From inlet, flow is diverted to one of the outlets; outlet port that is not active is vented to atmosphere.
Valve can be either spring return or two-position type.
- FLOW** Control Valve:
Allows free flow in one direction and controlled adjustable flow rate in the other direction.
- SHUTTLE** Valve:
Allows flow from either input to the output.
- PULSE** Valve:
A unitized valve that converts a continuous supply of air into an outlet pulse of air and then remains closed until the supply pressure is exhausted.

Pneumatics Problem #1

Application:

Finished parts are accumulating on the end of a conveyor. The parts need to be transferred on to a connecting conveyor that carries them to the final inspection and packaging stations. The technician needs to be able to activate and then release a transfer device powered by a pneumatic cylinder.

Objective:

To be able to design and assemble a circuit that extends and retracts a single acting, spring return cylinder.

Circuit Problem:

Using the given components and layout, design a schematic circuit which will operate a spring return cylinder with a two position, spring offset, three-way valve.

Design and draw schematic diagram.

Approved: _____

Connect components to match schematic diagram.

Operate and explain circuit to instructor.

Approved: _____

Layout of Components Needed:

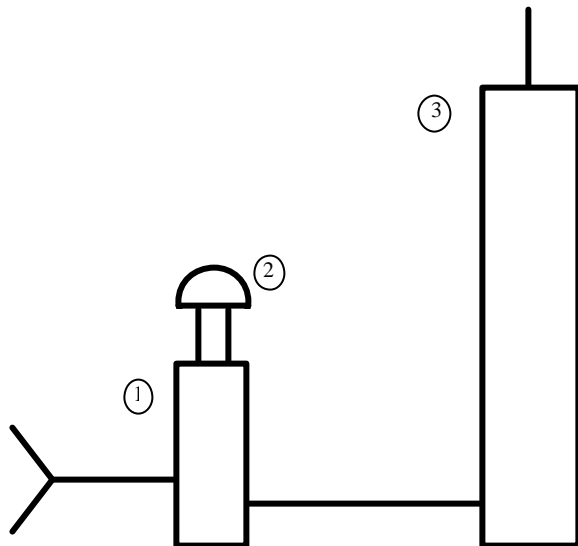

Part #	Component Description	Qty
1	2-position, spring offset, 3-way valve	1
2	push button actuator	1
3	single acting, spring return cylinder	1

NOTE: ACTUATORS MAY ALREADY BE ASSEMBLED ON A VALVE.

Pneumatics Problem #2

Application:

Parts need to be clamped for a drilling operation. The technician needs to activate and deactivate a pneumatic clamp that holds the part in a fixture on the drilling machine. The clamp must be activated before the drilling cycle begins and deactivated at the end of the drilling cycle.

Objective:

To be able to design and assemble a circuit that extends and retracts a double acting cylinder.

Circuit Problem:

Using the given components and layout, design a schematic circuit which will operate a double acting cylinder with a two position four-way valve.

Design and draw schematic diagram.

Approved: _____

Connect components to match schematic diagram.

Operate and explain circuit to instructor.

Approved: _____

Layout of Components Needed:

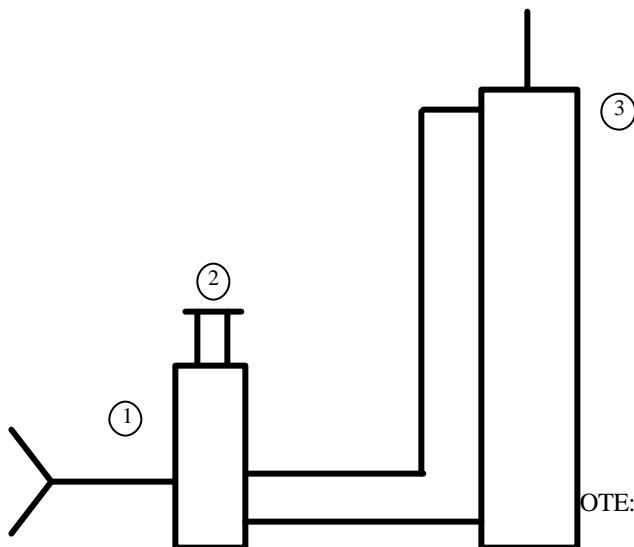

Part #	Component Description	Qty
1	2 position, 4-way valve	1
2	manual actuator	1
3	double acting cylinder	1

NOTE: ACTUATORS MAY ALREADY BE ASSEMBLED ON A VALVE.

Pneumatics Problem #3

Application:

A large stamping press must have a part in place, the clamps engaged and the safety guard closed before the press can operate. The pneumatic circuit needed for this type of machine is designed to minimize potential safety hazards.

Objective:

To be able to design and assemble an “AND” logic circuit.

Circuit Problem:

Using the given components and layout, design a schematic circuit which will only operate the cylinder when the three valves are all simultaneously operated, indicating the safety precautions are in place.

Design and draw schematic diagram.

Approved: _____

Connect components to match schematic diagram.

Operate and explain circuit to instructor.

Approved: _____

Layout of Components Needed:

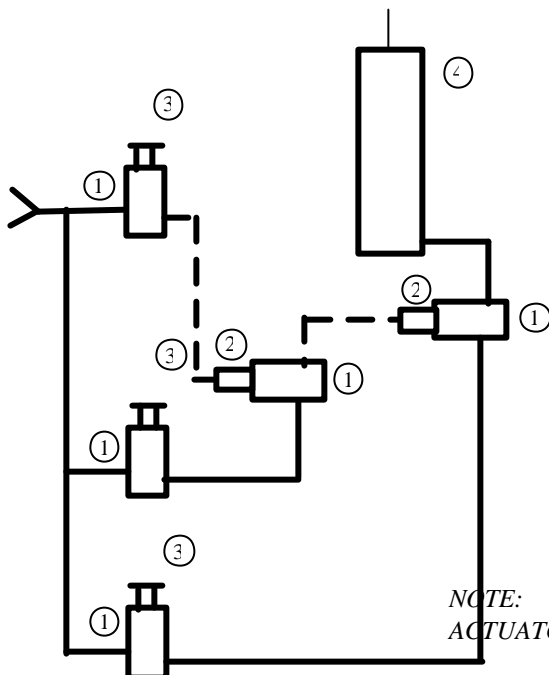

Part #	Component Description	Qty
1	2-position, spring offset, 3-way valve	5
2	air pilot actuator	2
3	manual actuator	3
4	single acting, spring return cylinder	1

*NOTE:
ACTUATORS MAY ALREADY BE ASSEMBLED ON THE VALVES.*

Pneumatics Problem #4

Application:

Parts are accumulating on a conveyor belt and waiting to be released and transferred to the next phase of assembly. Technicians at multiple stations need to control the gate release mechanism to have parts sent to their assembly station.

Objective:

To be able to design and assemble an “OR” logic circuit.

Circuit Problem:

Using the given components and layout, design a schematic circuit which will operate one spring return cylinder from any one of three identical valves.

Design and draw schematic diagram.

Approved: _____

Connect components to match schematic diagram.

Operate and explain circuit to instructor.

Approved: _____

Layout of Components Needed:

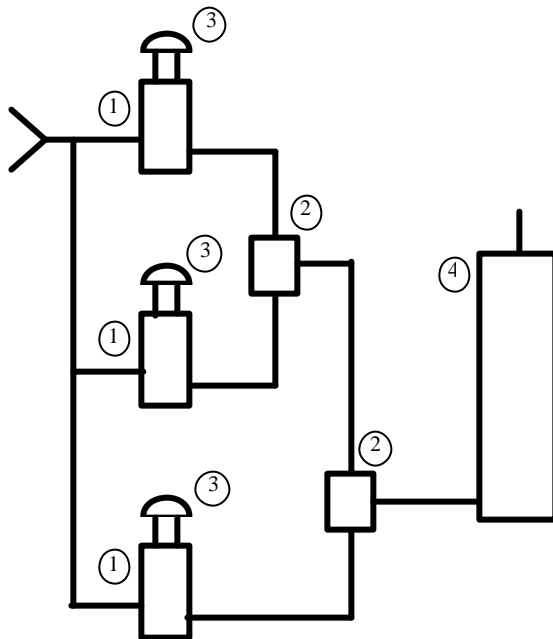

Part #	Component Description	Qty
1	2-position, spring offset, 3-way valve	3
2	shuttle valve	2
3	push button actuator	3
4	Single acting, spring return cylinder	1

N
NOTE: ACTUATORS MAY ALREA DY BE
ASSEMBLED ON A VALVE.

Pneumatics Problem #5

Application:

A plastic thermo-forming machine is capable of heating and forming parts of various thicknesses. The parts must be held in their molded positions while the plastic is curing in its final form. The length of time needed to cure the plastic will vary depending on the thickness. This in turn will require a forming operation that has a variable time delay before the part is automatically released.

Objective:

To be able to design and assemble a “LIMITED MEMORY” circuit.

Circuit Problem:

Using the given components and layout, design a schematic circuit which will extend a cylinder for an adjustable period of time, then automatically retract the cylinder.

Design and draw schematic diagram.

Approved: _____

Connect components to match schematic diagram.

Operate and explain circuit to instructor.

Approved: _____

Layout of Components Needed:

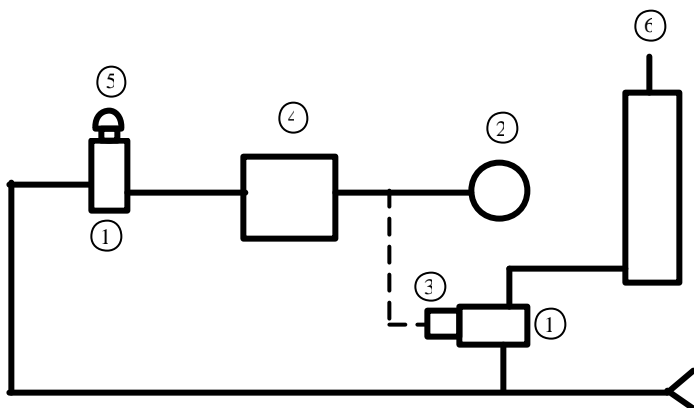

Part #	Component Description	Qty
1	2-position, spring offset, 3-way valve	2
2	volume chamber	1
3	air pilot actuator	1
4	flow control valve	1
5	push button actuator	1
6	single acting, spring return cylinder	1

NOTE: ACTUATORS MAY ALREADY BE ASSEMBLED ON A VALVE.

Pneumatics Problem #6

Application:

A gravel yard has a single conveyor that can transport gravel to two different loading docks. In order to shift the out feed of the conveyor to the alternate loading dock the operator must push a button. As a safety precaution, the conveyor will always be held in the last shifted position.

Objective:

To be able to design and assemble an “FULL MEMORY” circuit.

Circuit Problem:

Using the given components and layout, design a schematic circuit that requires the operator to push one of two buttons that in turn shifts a detented, two position, four-way valve. The valve is air-piloted in both directions and operates a double acting cylinder.

Design and draw schematic diagram.

Approved: _____

Connect components to match schematic diagram.

Operate and explain circuit to instructor.

Approved: _____

Layout of Components Needed:

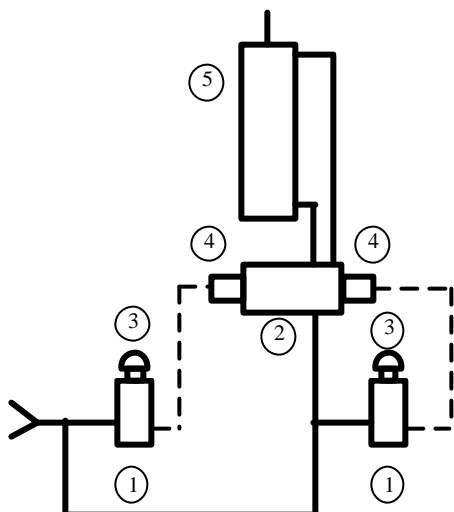

Part #	Component Description	Qty
1	2-position, spring offset, 3-way valve	2
2	2-position, detented, 4-way valve	1
3	push button actuator	2
4	air pilot actuator	2
5	double acting cylinder	1

NOTE: ACTUATORS MAY ALREADY BE ASSEMBLED ON A VALVE.

Pneumatics Problem #7

Application:

Boxes are being filled with packing material that is dispensed in a time-released quantity. The exact amount of packing material needed is dispensed in one cycle. The operator must not be able to double pack the boxes, which would create an overflow situation. The operator will push a button to activate the dispensing gate. Once the button is pushed the cycle will continue until completed. A new cycle cannot be started until the first cycle is completed and the push button released. Even if the push button is held down continuously, a new cycle cannot be started.

Objective:

To be able to design and assemble a “ONE SHOT CYCLE” circuit.

Circuit Problem:

Using the given components and layout, design a schematic circuit which will only operate the cylinder for one timed cycle. No matter how long the valve is held shifted, only one cycle of the cylinder will result. The pulse valve controls the time delay before the retraction of the cylinder. The one shot cycle is a limited memory time function.

Design and draw schematic diagram.

Approved: _____

Connect components to match schematic diagram.

Operate and explain circuit to instructor.

Approved: _____

Layout of Components Needed:

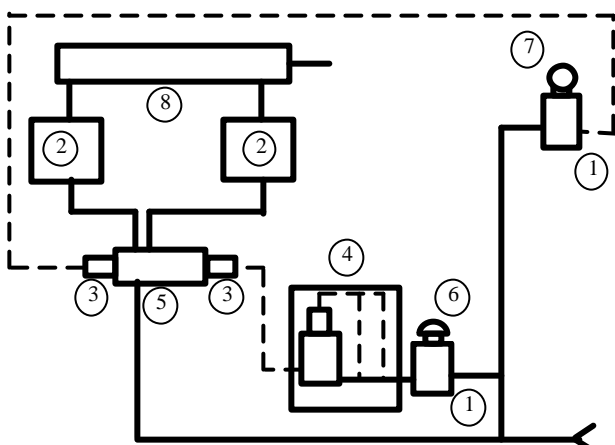

Part #	Component Description	Qty
1	2-position, spring offset, 3-way valve	2
2	flow control valve	2
3	air pilot actuator	2
4	pulse valve	1
5	2-position, detented, 4-way valve	1
6	push button actuator	1
7	mechanical actuator	1
8	double acting cylinder	1

NOTE: ACTUATORS MAY ALREADY BE ASSEMBLED ON A VALVE.

Pneumatics Problem #8

Application:

The machine head of a precision grinder needs to continuously reciprocate over a cylinder head surface being finished. The speed of the stroke must be controlled in both directions.

Objective:

To be able to design and assemble an “AUTOMATIC CAM CYCLING” circuit.

Circuit Problem:

Using the given components and layout, design a schematic circuit that automatically cycles the continuous reciprocation of a cylinder. Limit valves located at the full extension and retraction of the cylinder are mechanically (cam) operated. Flow control valves that control the flow of the exhaust air leaving the cylinder (bleeding out) govern the speed of the operation. The cycle is started and stopped the shifting of toggle valve.

Design and draw schematic diagram.

Approved: _____

Connect components to match schematic diagram.

Operate and explain circuit to instructor.

Approved: _____

Layout of Components Needed:

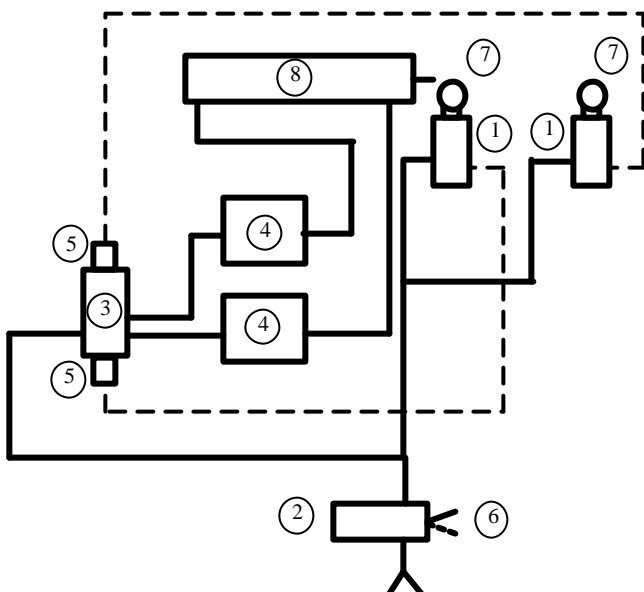

Part #	Component Description	Qty
1	2-position, spring offset, 3-way valve	2
2	2-position, 3-way valve	1
3	2-position, detented, 4-way valve	1
4	flow control valve	2
5	air pilot actuator	2
6	manual actuator	1
7	mechanical actuator	2
8	double acting cylinder	1

NOTE: ACTUATORS MAY ALREADY
BE ASSEMBLED ON A VALVE.

Pneumatics Problem #9

Application:

The material transfer portion of a progressive die machine needs to be manually indexed by the operator shifting a valve. When this happens, the locator pins are released and the sheet metal roll advances to the next die. The locating pins can only be released while the sheet metal roll is advancing.

Objective:

To be able to design and assemble a “ONE CYCLE – THEN RESET” circuit.

Circuit Problem:

Using the given components and layout, design a schematic circuit that will extend a double acting cylinder while simultaneously extending a spring return cylinder. The spring return cylinder is operated when a cam follower is actuated and can only operate during the extension of the double acting cylinder. When the double acting cylinder is fully extended it actuates a cam follower that causes it to retract and be ready for another cycle (reset). When the double acting cylinder retracts, no action occurs upon actuating the cam follower.

Design and draw schematic diagram.

Approved: _____

Connect components to match schematic diagram.

Operate and explain circuit to instructor.

Approved: _____

Layout of Components Needed:

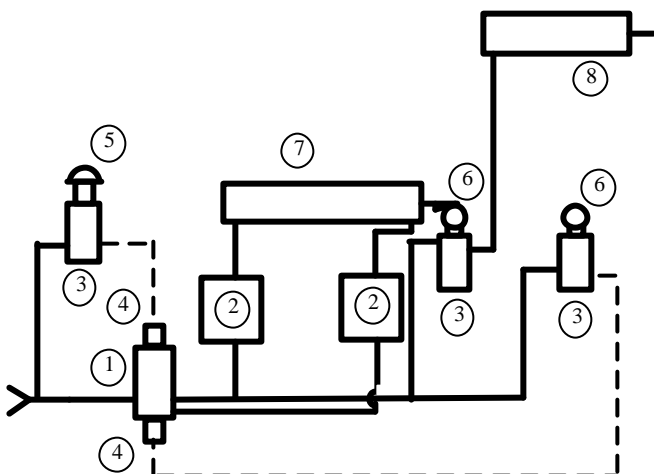

Part #	Component Description	Qty
1	2-position, detented, 4-way valve	1
2	flow control valve	2
3	2-position, spring offset, 3-way valve	3
4	air pilot actuator	2
5	push button actuator	1
6	mechanical actuator	2
7	double acting cylinder	1
8	single acting, spring return cylinder	1

NOTE: ACTUATORS MAY ALREADY BE ASSEMBLED ON A VALVE.

Pneumatics Problem #10

Application:

A power door opening system must be controlled with a timed cycle. Operators need to activate the door cycle from both inside and outside by pushing a button. The door needs to remain open for an adjustable time period before it automatically closes. The operators must also have a means to keep the door open continuously when needed.

Objective:

To be able to design and assemble a “DOOR OPENER – DELAY SHUT” circuit.

Circuit Problem:

Using the given components and layout, design a schematic circuit which allows two valves to start a cycle that extends a cylinder for an adjustable time period and then retracts it. The adjustable time delay is controlled by a “limited memory” circuit. A third valve (toggle valve) must have the ability to extend the cylinder and keep the cylinder extended until the operator wants it retracted.

Design and draw schematic diagram.

Approved: _____

Connect components to match schematic diagram.

Operate and explain circuit to instructor.

Approved: _____

Layout of Components Needed:

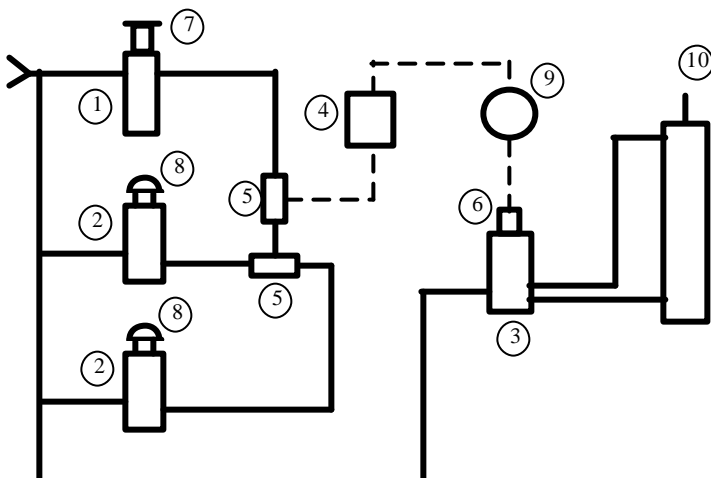

Part #	Component Description	Qty
1	2-position, 3-way valve	1
2	2-position, spring offset, 3-way valve	2
3	2-position, spring offset, 4-way valve	1
4	flow control valve	1
5	shuttle valve	2
6	air pilot actuator	1
7	manual actuator	1
8	push button actuator	2
9	volume chamber	1
10	double acting cylinder	1

Note: Actuator may already be assembled on a Valve

Pneumatics Problem #16

Application:

A pallet of parts has to be lifted and then transferred onto an Automatic Guided Vehicle (AGV) to be transported to a loading dock. The machine operator needs to make this happen automatically by pushing and releasing a button one time.

Objective:

To be able to design and assemble a machine control circuit that safely sequences two double acting cylinders.

Circuit Problem:

Upon momentary actuation of a start button, a double acting cylinder extends to its limit that automatically extends a second double acting cylinder to its limit. This automatically causes the first cylinder to retract, which causes the second cylinder to retract. The cycle can not be restarted until the second cylinder is fully retracted.

Using the given table of components below, design and assemble a schematic circuit that will correctly and safely operate this machine control application.

Design and draw schematic diagram.

Approved: _____

Connect components to match schematic diagram.

Operate and explain circuit to instructor.

Approved: _____

Components Needed:

Part #	Component Description	Qty
1	Double Acting Cylinder	2
2	3 Way, 2 Position, Manually Operated, Spring Return, Directional Control Valve	1
3	4 Way, 2 Position, Double Air Pilot Operated, Detented, Directional Control Valve	2
4	3 Way, 2 Position, Cam Operated, Spring Return, Limit Valve (normally non-passing)	4
5	3 Way, 2 Position, Single Air Pilot Operated, Spring Return, Directional Control Valve	1