



ST763A series

3.3V Step down current mode PWM DC-DC converters

Feature summary

- Output voltage 3.3V
- Supply voltage range from 3.3V to 11V
- Guaranteed output current: 500mA
- Typical operation frequency: 200KHz
- Very low quiescent current: 0.6mA on mode
0.2 μ A OFF MODE
- Switch ON/OFF control
- Typical efficiency: 90%
- Operating temperature range: -40°C TO 85°C
- Available in SO-8 and DIP-8 packages

Description

The ST763A is a step-down switching regulator. It operates from 3.3V to 11V giving a fixed 3.3V output voltage, delivering up to 500mA. The mainly features are typical efficiency of 90%, quiescent current of 0.6mA, and only 0.2 μ A in shut-down.

The PWM current mode control provides precise output regulation and very good transient response. Output voltage accuracy is guaranteed to be $\pm 5\%$ over line, load and temperature

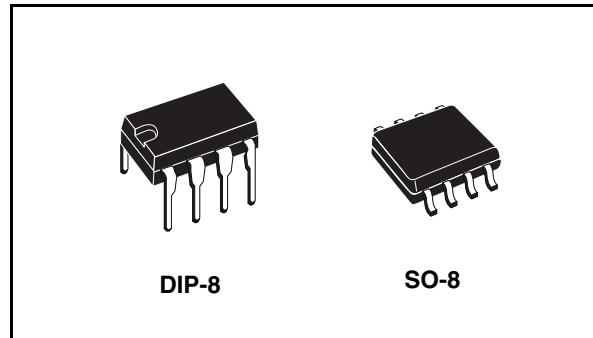

variations. A minimum number of external components is used and the fixed frequency switching allows easy filtering of output ripple and noise.

Other features of this device are cycle-by-cycle current limiting, overcurrent limiting, under voltage lockout and programmable soft-start protection.

A 22 μ H inductor works in most applications, so no sophisticated design is necessary.

Package available are SO-8 and DIP-8.

Typical application are in 5V to 3.3V converters, cellular phones, portable instruments, hand-held computers, and peripherals.

Order code

Part number	Package		Packaging
	DIP-8	SO-8	SO-8 (T&R)
ST763AB	ST763ABN	ST763ABD	ST763ABDTR
ST763AC	ST763ACN	ST763ACD	ST763ACDTR

Contents

1	Diagram	3
2	Pin configuration	4
3	Maximum ratings	5
4	Typical application	6
5	Electrical characteristics	7
6	Typical performance characteristics	8
7	Package mechanical data	11
8	Revision history	15

1 Diagram

Figure 1. Schematic diagram

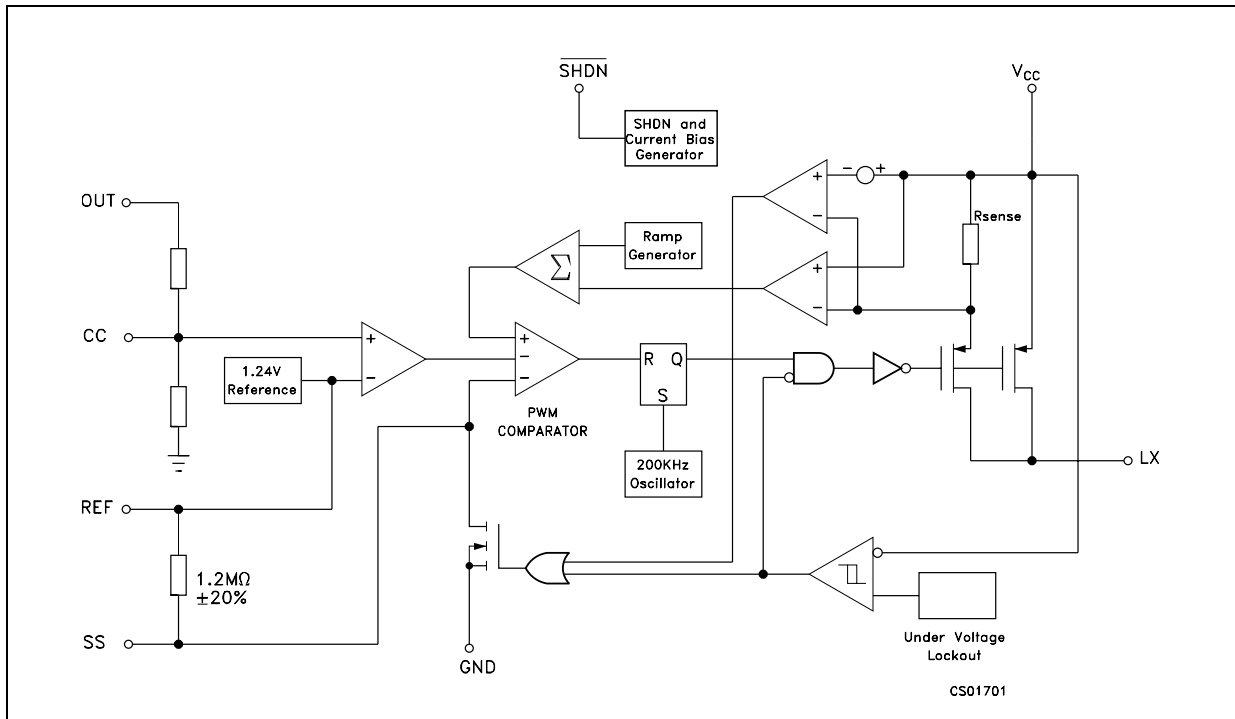

2 Pin configuration

Figure 2. Pin connections (top view)

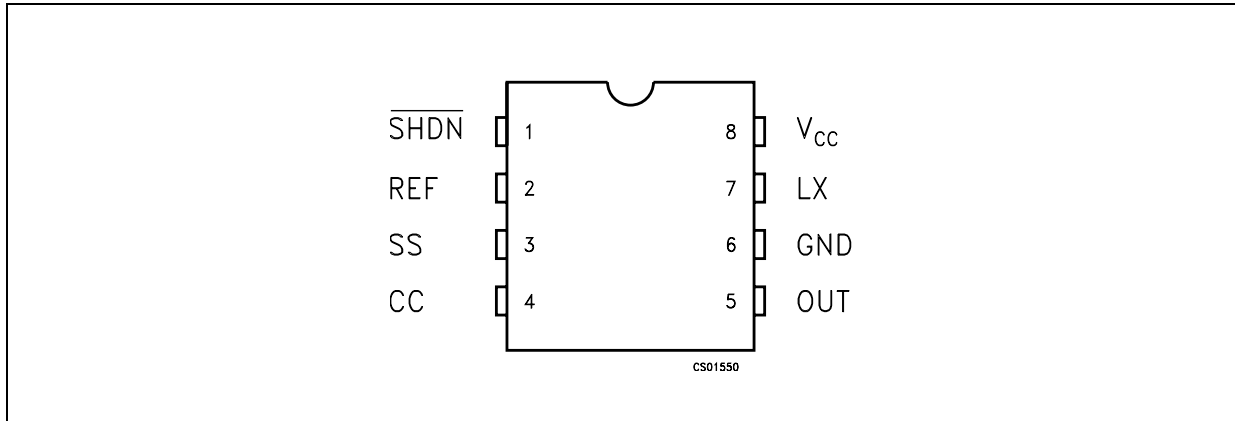

Table 1. Pin description

Pin N°	Symbol	Name and function
1	$\overline{\text{SHDN}}$	Shutdown control (active low): If connected to GND the IC is in shutdown. Connect to V_{CC} for normal operation (ON MODE).
2	REF	Reference output voltage: (1.25V): Bypass to GND with 47nF capacitor.
3	SS	Soft start: a capacitor between SS and GND provides soft-start and short-circuit protections.
4	CC	Compensation capacitor input: externally compensates the outer (voltage) feedback loop. Connect to OUT with 330pF capacitor
5	OUT	Output voltage sense input: provides regulation of feedback sensing. Connect to 3.3V output.
6	GND	Ground
7	LX	Switch output. Drain of internal P-Channel Power MOSFET
8	V_{CC}	Supply voltage input. Bypass to GND with 1 μ F ceramic capacitance and large value electrolytic capacitor in parallel. The 1 μ F capacitor must be as close as possible to the GND and V_{CC} pins.

3 Maximum ratings

Table 2. Absolute maximum ratings

Symbol	Parameter		Value	Unit
V_{CC}	DC Input voltage		-0.3 to 12	V
V_{LX}	Switch pin voltage		-0.3 to ($V_{CC} + 0.3$)	V
V_{SHDN}	Shutdown voltage (SHDN)		-0.3 to ($V_{CC} + 0.3$)	V
V_S, V_C	Soft start (SS) and compensation capacitor (CC) pins voltage		-0.3 to ($V_{CC} + 0.3$)	V
I_{LX}	Switching peak current		2	A
I_{REF}	Reference current		2.5	mA
P_{TOT}	Continuous power dissipation at $T_A=70^\circ\text{C}$	DIP-8	550	mW
		SO-8	344	
T_{stg}	Storage temperature range		-40 to +150	$^\circ\text{C}$
T_{op}	Operating junction temperature range	AC series	0 to +70	$^\circ\text{C}$
		AB series	-40 to +85	

Note: Absolute Maximum Ratings are those values beyond which damage to the device may occur. Functional operation under these condition is not implied

Table 3. Thermal data

Symbol	Parameter	SO-8	DIP-8	Unit
R_{thJA}	Thermal resistance junction-ambient ⁽¹⁾	160	100	$^\circ\text{C}/\text{W}$

1. This value depends from thermal design of PCB on which the device is mounted.

4 Typical application

Figure 3. Application circuit

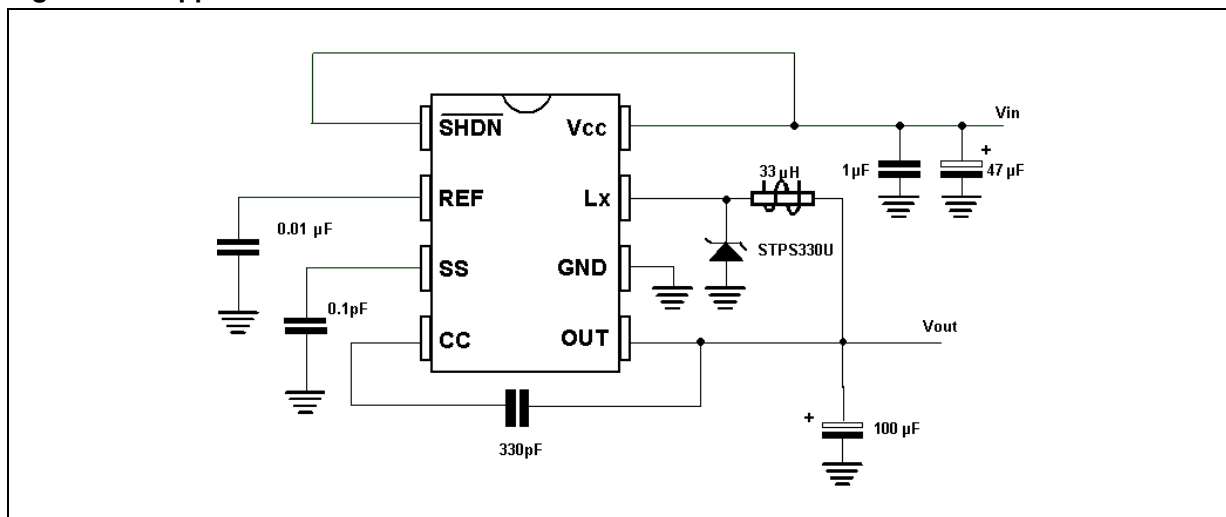

5 Electrical characteristics

Table 4. Electrical characteristics

($V_{CC}=5V$, $I_O = 0mA$, $T_A = T_{MIN}$ to T_{MAX} , unless otherwise specified).

Symbol	Parameter	Test conditions	Min.	Typ.	Max.	Unit
V_{CC}	Input voltage		3.3		11	V
V_O	Output voltage	$V_{CC} = 4$ to $11V$, $I_O = 0$ to $300mA$	3.135	3.3	3.465	V
		$V_{CC} = 4.75$ to $11V$, $I_O = 0$ to $500mA$	3.135	3.3	3.465	V
ΔV_O	Line regulation			0.13		%/V
ΔV_O	Load regulation	$I_O = 0$ to $500mA$		0.005		%/mA
η	Power efficiency	$I_O = 300mA$		88		%
		$I_O = 100mA$		90		
I_{SUPPLY}	Supply current	ON Mode (Including switch current)		0.6	2.5	mA
		OFF Mode		0.2	100	μA
V_{IH}	SHDN Input high threshold		2			V
V_{IL}	SHDN Input low threshold				0.25	V
I_{SHDN}	Shutdown input leakage current				1	μA
V_{LOCK}	Under voltage lockout	V_{CC} Falling		2.7	3	V
$R_{DS(on)}$	LX On resistance	$I_{LX} = 500mA$		1		Ω
I_{LEAK}	LX Leakage current	$V_{CC} = 12V$, $V_{LX} = 0V$		10		nA
V_{REF}	Reference voltage	$T_A = 25^\circ C$	1.18	1.25	1.32	V
ΔV_{REF}	Temperature reference drift	$T_A = T_{MIN}$ to T_{MAX}		50		ppm/ $^\circ C$
f_{OSC}	Switching frequency	$T_A = 25^\circ C$	159	200	212.5	KHz
R_C	Compensation pin impedance			7500		Ω

6 Typical performance characteristics

(Unless otherwise specified $T_J = 25^\circ\text{C}$)

Figure 4. Output voltage vs temperature

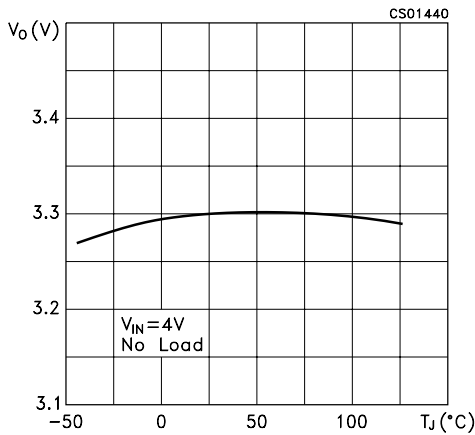

Figure 5. Output voltage vs input voltage

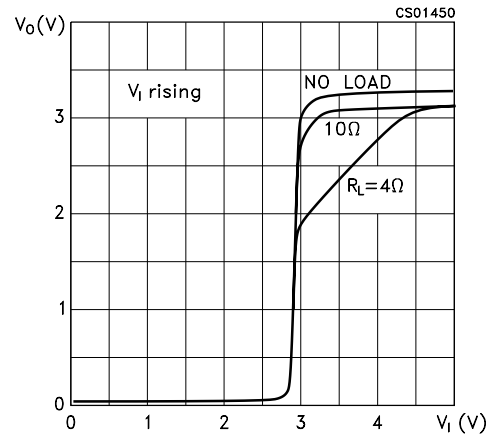

Figure 6. Reference voltage vs temperature

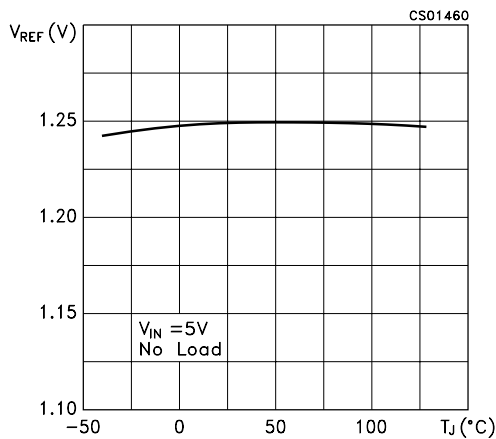

Figure 7. Efficiency vs temperature

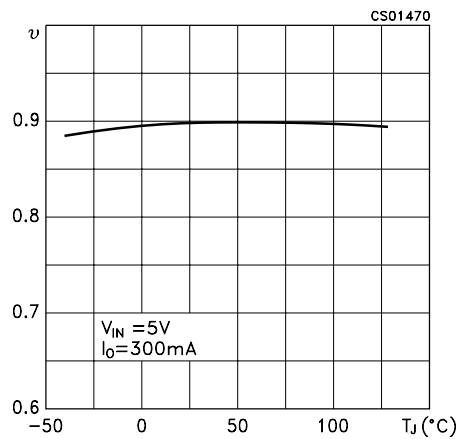

Figure 8. Efficiency vs output current

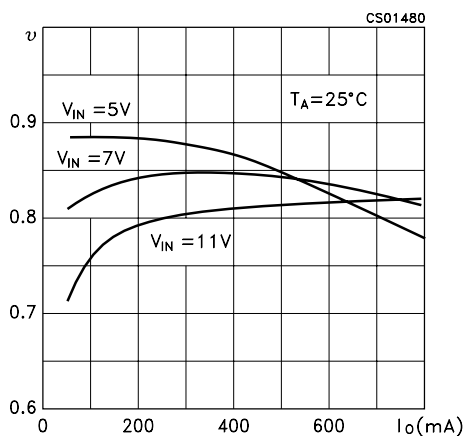

Figure 9. LX leakage current vs temperature

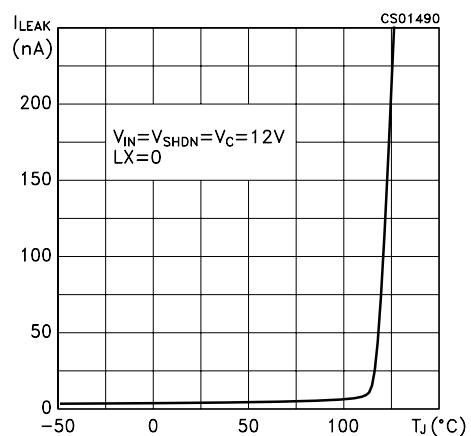

Figure 10. LX ON Resistance vs temperature

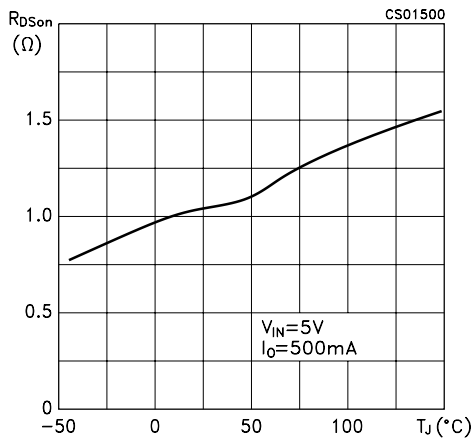

Figure 11. Shutdown input threshold vs temperature

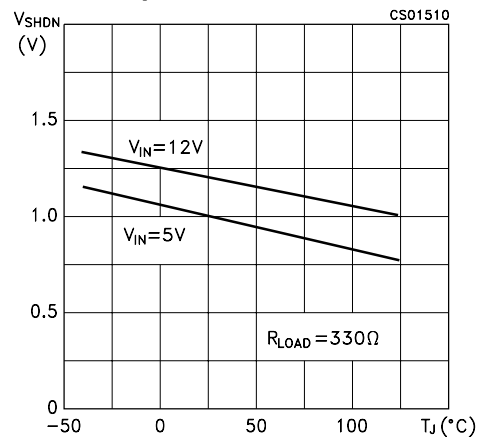

Figure 12. Shutdown input leakage current vs temperature

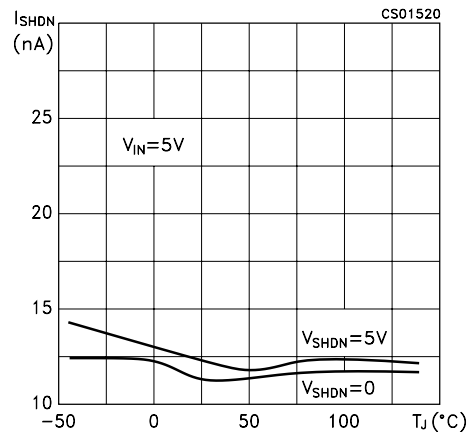

Figure 13. Oscillator frequency vs temperature

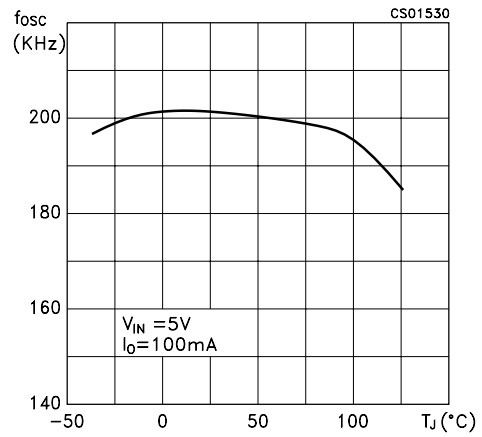

Figure 14. Oscillator frequency vs input voltage

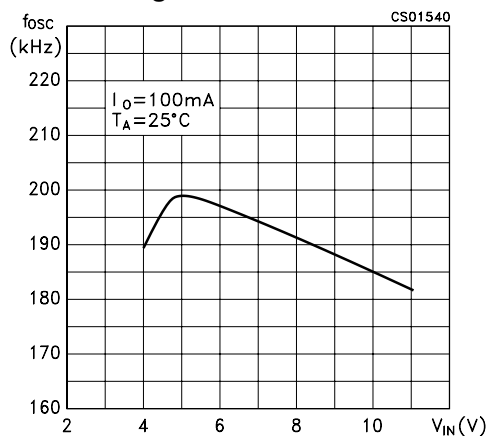
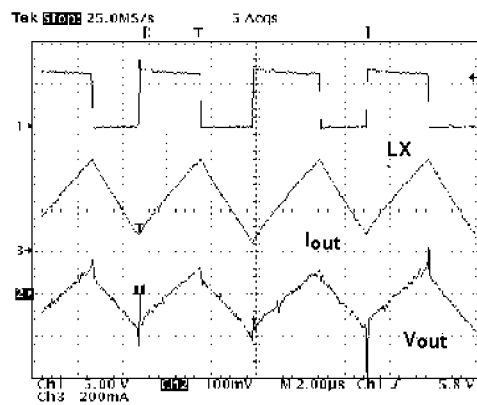
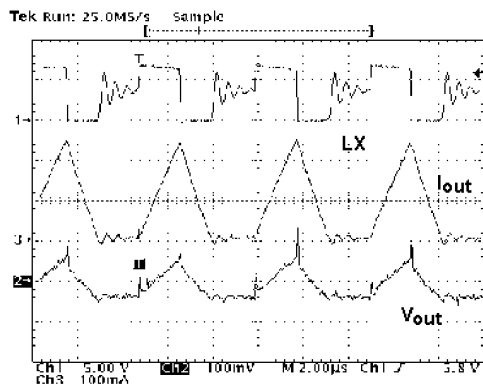

Figure 15. Switching waveform, continuous conduction



V_I=6V, I_O=250mA

Figure 16. Switching waveform, discontinuous conduction



$V_I=6V, I_O=75mA$

Figure 17. Load transient

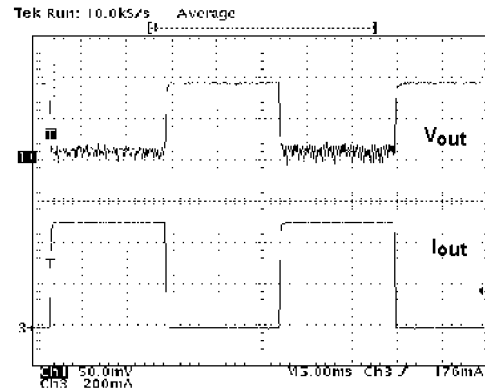

$V_I=5V, I_O=0 \text{ to } 500mA$

Figure 18. Line transient

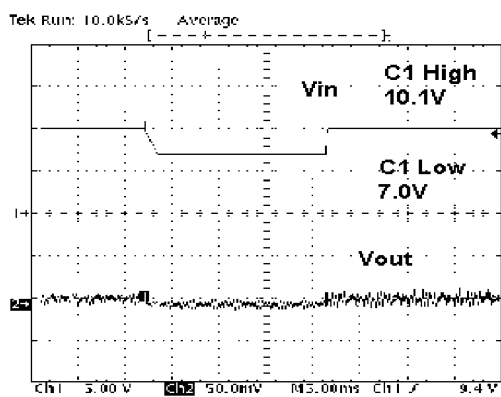

$I_O=350mA$

7 Package mechanical data

In order to meet environmental requirements, ST offers these devices in ECOPACK® packages. These packages have a Lead-free second level interconnect. The category of second Level Interconnect is marked on the package and on the inner box label, in compliance with JEDEC Standard JESD97. The maximum ratings related to soldering conditions are also marked on the inner box label. ECOPACK is an ST trademark. ECOPACK specifications are available at: www.st.com.

Plastic DIP-8 MECHANICAL DATA

DIM.	mm.			inch		
	MIN.	TYP	MAX.	MIN.	TYP.	MAX.
A		3.3			0.130	
a1	0.7			0.028		
B	1.39		1.65	0.055		0.065
B1	0.91		1.04	0.036		0.041
b		0.5			0.020	
b1	0.38		0.5	0.015		0.020
D			9.8			0.386
E		8.8			0.346	
e		2.54			0.100	
e3		7.62			0.300	
e4		7.62			0.300	
F			7.1			0.280
l			4.8			0.189
L		3.3			0.130	
Z	0.44		1.6	0.017		0.063

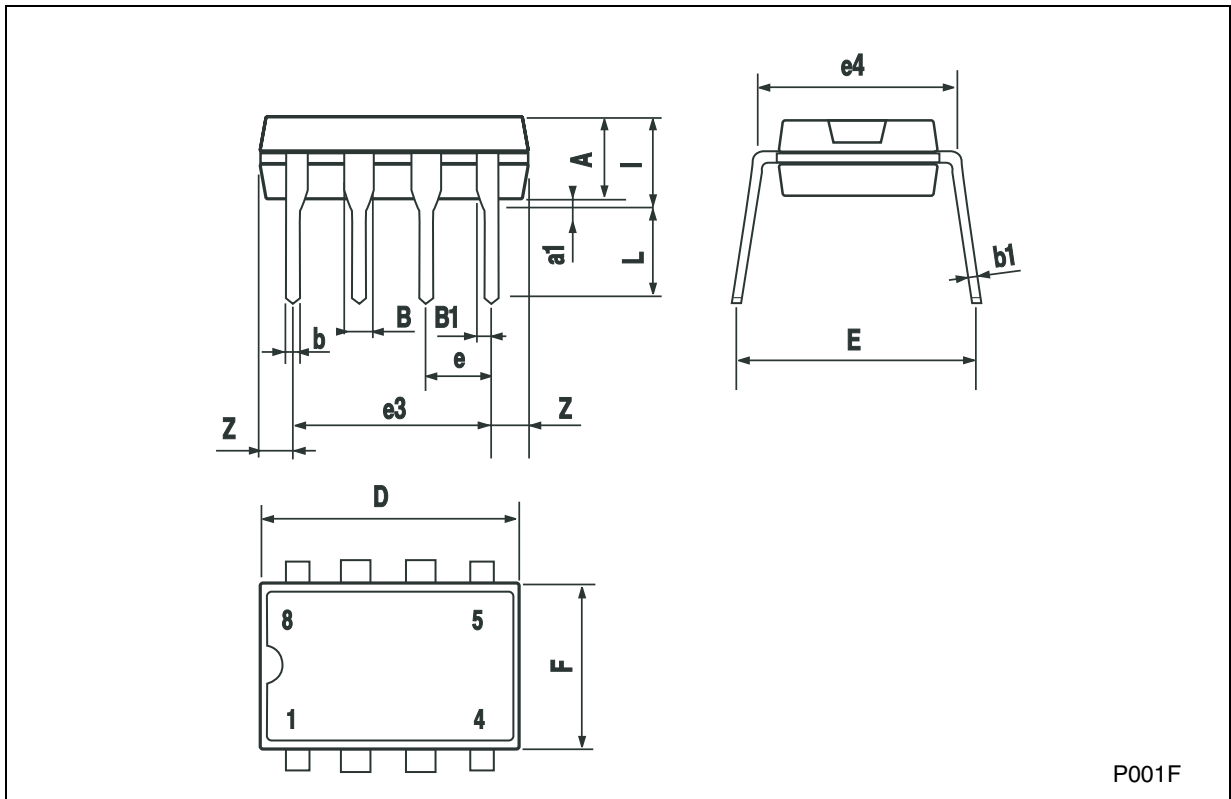

P001F

SO-8 MECHANICAL DATA

DIM.	mm.			inch		
	MIN.	TYP	MAX.	MIN.	TYP.	MAX.
A	1.35		1.75	0.053		0.069
A1	0.10		0.25	0.04		0.010
A2	1.10		1.65	0.043		0.065
B	0.33		0.51	0.013		0.020
C	0.19		0.25	0.007		0.010
D	4.80		5.00	0.189		0.197
E	3.80		4.00	0.150		0.157
e		1.27			0.050	
H	5.80		6.20	0.228		0.244
h	0.25		0.50	0.010		0.020
L	0.40		1.27	0.016		0.050
k	8° (max.)					
ddd			0.1			0.04

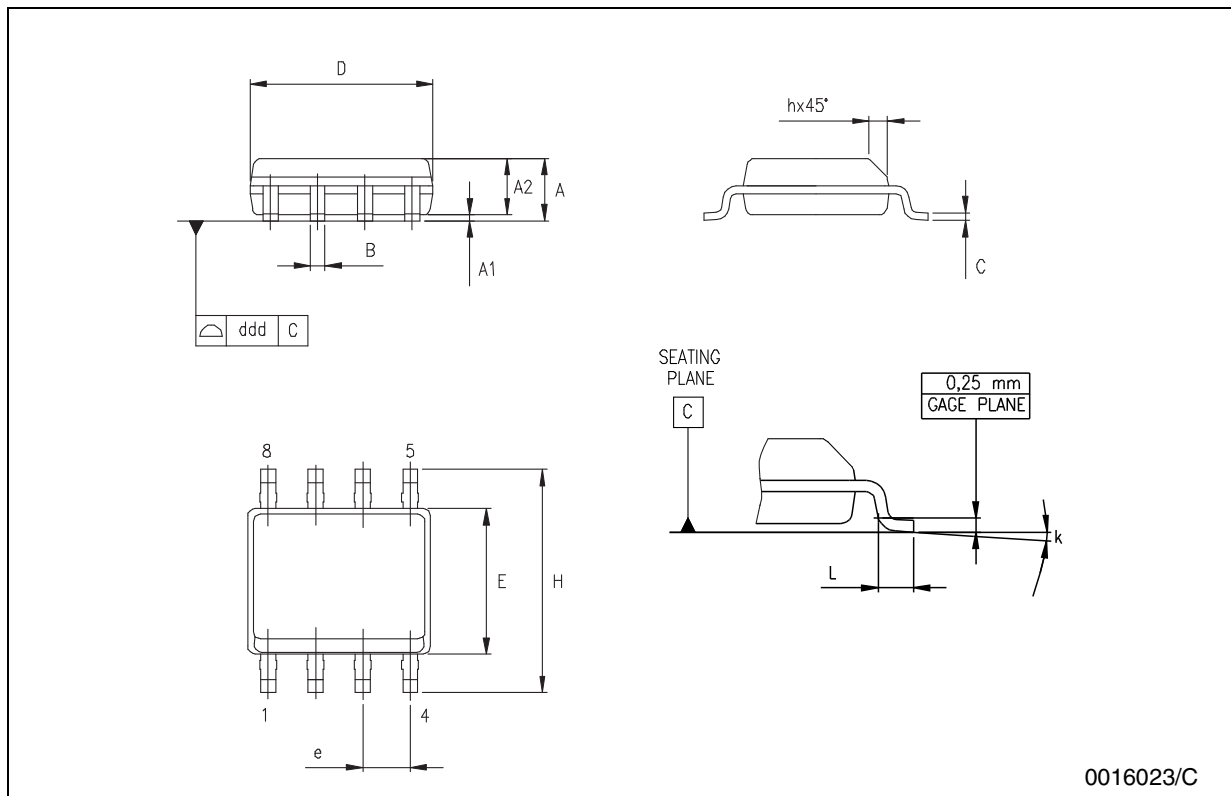

Tape & Reel SO-8 MECHANICAL DATA

DIM.	mm.			inch		
	MIN.	TYP	MAX.	MIN.	TYP.	MAX.
A			330			12.992
C	12.8		13.2	0.504		0.519
D	20.2			0.795		
N	60			2.362		
T			22.4			0.882
Ao	8.1		8.5	0.319		0.335
Bo	5.5		5.9	0.216		0.232
Ko	2.1		2.3	0.082		0.090
Po	3.9		4.1	0.153		0.161
P	7.9		8.1	0.311		0.319

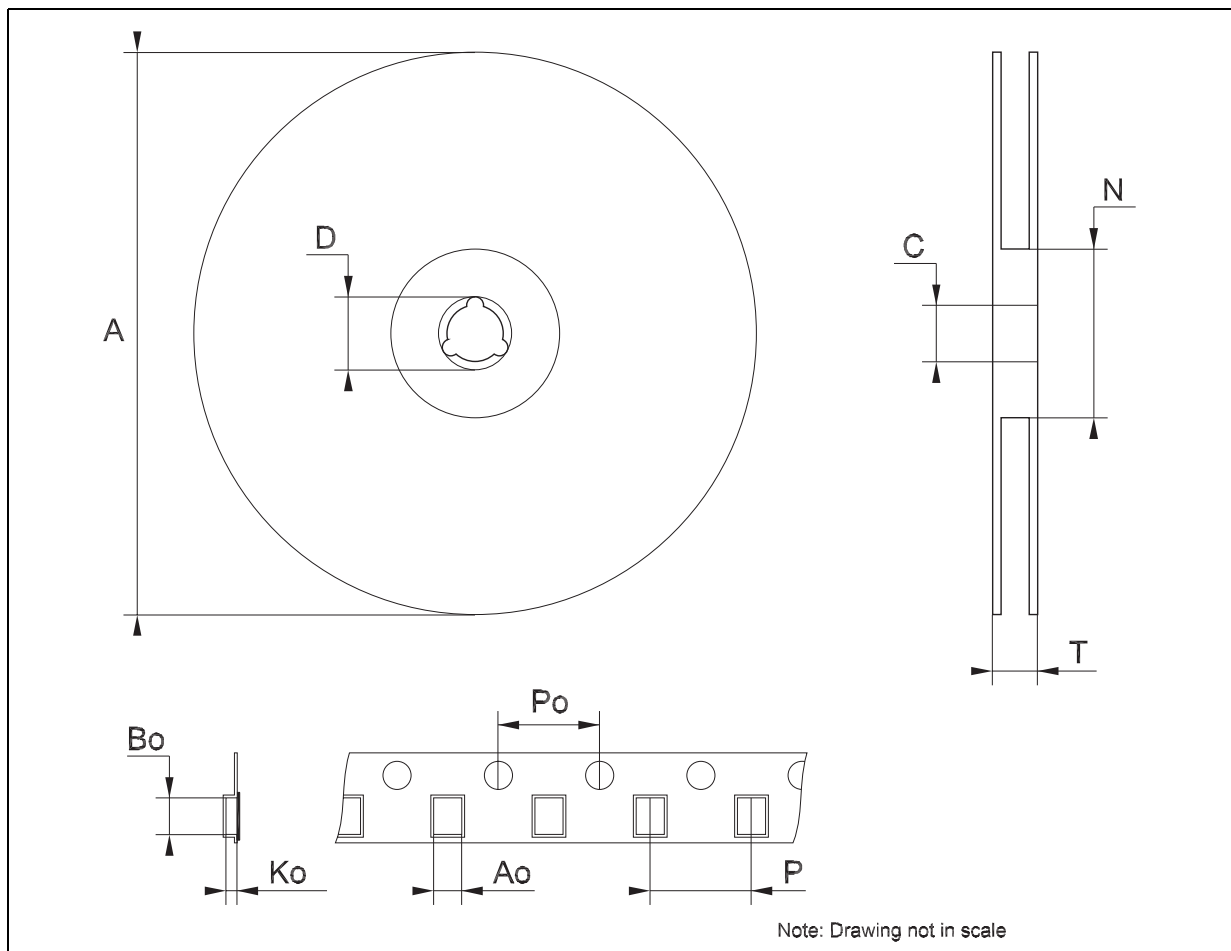

8 Revision history

Table 5. Revision history

Date	Revision	Changes
26-May-2006	2	Add T_A row f_{OSC} on table 4 and new template.

Please Read Carefully:

Information in this document is provided solely in connection with ST products. STMicroelectronics NV and its subsidiaries ("ST") reserve the right to make changes, corrections, modifications or improvements, to this document, and the products and services described herein at any time, without notice.

All ST products are sold pursuant to ST's terms and conditions of sale.

Purchasers are solely responsible for the choice, selection and use of the ST products and services described herein, and ST assumes no liability whatsoever relating to the choice, selection or use of the ST products and services described herein.

No license, express or implied, by estoppel or otherwise, to any intellectual property rights is granted under this document. If any part of this document refers to any third party products or services it shall not be deemed a license grant by ST for the use of such third party products or services, or any intellectual property contained therein or considered as a warranty covering the use in any manner whatsoever of such third party products or services or any intellectual property contained therein.

UNLESS OTHERWISE SET FORTH IN ST'S TERMS AND CONDITIONS OF SALE ST DISCLAIMS ANY EXPRESS OR IMPLIED WARRANTY WITH RESPECT TO THE USE AND/OR SALE OF ST PRODUCTS INCLUDING WITHOUT LIMITATION IMPLIED WARRANTIES OF MERCHANTABILITY, FITNESS FOR A PARTICULAR PURPOSE (AND THEIR EQUIVALENTS UNDER THE LAWS OF ANY JURISDICTION), OR INFRINGEMENT OF ANY PATENT, COPYRIGHT OR OTHER INTELLECTUAL PROPERTY RIGHT.

UNLESS EXPRESSLY APPROVED IN WRITING BY AN AUTHORIZED REPRESENTATIVE OF ST, ST PRODUCTS ARE NOT DESIGNED, AUTHORIZED OR WARRANTED FOR USE IN MILITARY, AIR CRAFT, SPACE, LIFE SAVING, OR LIFE SUSTAINING APPLICATIONS, NOR IN PRODUCTS OR SYSTEMS, WHERE FAILURE OR MALFUNCTION MAY RESULT IN PERSONAL INJURY, DEATH, OR SEVERE PROPERTY OR ENVIRONMENTAL DAMAGE.

Resale of ST products with provisions different from the statements and/or technical features set forth in this document shall immediately void any warranty granted by ST for the ST product or service described herein and shall not create or extend in any manner whatsoever, any liability of ST.

ST and the ST logo are trademarks or registered trademarks of ST in various countries.

Information in this document supersedes and replaces all information previously supplied.

The ST logo is a registered trademark of STMicroelectronics. All other names are the property of their respective owners.

© 2006 STMicroelectronics - All rights reserved

STMicroelectronics group of companies

Australia - Belgium - Brazil - Canada - China - Czech Republic - Finland - France - Germany - Hong Kong - India - Israel - Italy - Japan - Malaysia - Malta - Morocco - Singapore - Spain - Sweden - Switzerland - United Kingdom - United States of America

www.st.com