



1.0 Introduction

1.1 APPLICATION NOTE OBJECTIVE

This application note is intended to explain and complement the information in the data sheet and also address the common user questions. While no initial familiarity with the LM628/629 is assumed, it will be useful to have the LM628/629 data sheet close by to consult for detailed descriptions of the user command set, timing diagrams, bit assignments, pin assignments, etc.

After the following brief description of the LM628/629, Section 2.0 gives a fairly full description of the device's operation, probably more than is necessary to get going with the device. This section ends with an outline of how to tune the control system by adjusting the PID filter coefficients.

Section 3 "User Command Set" discusses the use of the LM628/629 commands. For a detailed description of each command the user should refer to the data sheet.

Section 4 "Helpful User Ideas" starts with a short description of the actions necessary to get going, then proceeds to talk about some performance enhancements and follows on with a discussion of a couple of operating constraints of the device.

Section 5 "Theory" is a short foray into theory which relates the PID coefficients that would be calculated from a continu-

ous domain control loop analysis to those of the discrete domain including the scaling factors inherent to the LM628/629. No attempt is made to discuss control system theory as such, readers should consult the ample references available, some suggestions are made at the end of this application note. Section 5 concludes with an example trajectory calculation, reviving those perhaps forgotten ideas about acceleration, velocity, distance and time.

Section 6 "Questions and Answers", is in question and answer format and is born out of and dedicated to the many interesting discussions with customers that have taken place.

1.2 BRIEF DESCRIPTION OF LM628/629

LM628/629 is a microcontroller peripheral that incorporates in one device all the functions of a sample-data motion control system controller. Using the LM628/629 makes the potentially complex task of designing a fast and precise motion control system much easier. Additional features, such as trajectory profile generation, on the "fly" update of loop compensation and trajectory, and status reporting, are included. Both position and velocity motion control systems can be implemented with the LM628/629.

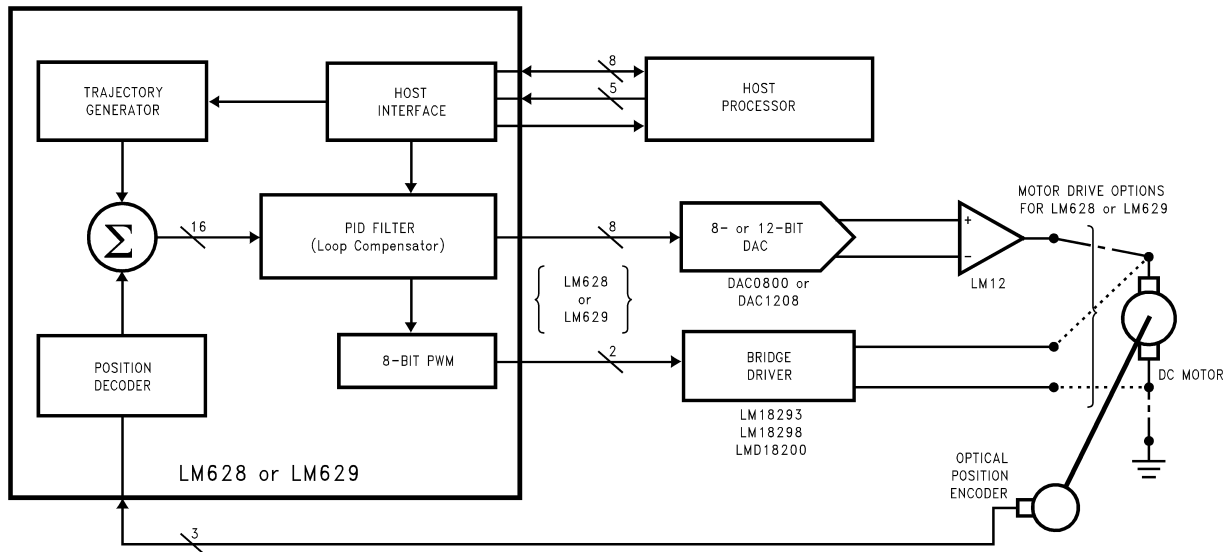

01101801

FIGURE 1. LM628 and LM629 Typical System Block Diagram

LM628/629 is itself a purpose designed microcontroller that implements a position decoder, a summing junction, a digital PID loop compensation filter, and a trajectory profile generator, *Figure 1*. Output format is the only difference between LM628 and LM629. A parallel port is used to drive an 8- or 12-bit digital-to-analog converter from the LM628 while the

LM629 provides a 7-bit plus sign PWM signal with sign and magnitude outputs. Interface to the host microcontroller is via an 8-bit bi-directional data port and six control lines which includes host interrupt and hardware reset. Maximum sampling rates of either 2.9 kHz or 3.9 kHz are available by

1.0 Introduction (Continued)

choosing the LM6268/9 device options that have 6 MHz or 8 MHz maximum clock frequencies (device -6 or -8 suffixes). In operation, to start a movement, a host microcontroller downloads acceleration, velocity and target position values to the LM628/629 trajectory generator. At each sample interval these values are used to calculate new demand or "set point" positions which are fed into the summing junction. Actual position of the motor is determined from the output signals of an optical incremental encoder. Decoded by the LM628/629's position decoder, actual position is fed to the other input of the summing junction and subtracted from the demand position to form the error signal input for the control loop compensator. The compensator is in the form of a "three term" PID filter (proportional, integral, derivative), this is implemented by a digital filter. The coefficients for the PID digital filter are most easily determined by tuning the control

system to give the required response from the load in terms of accuracy, response time and overshoot. Having characterized a load these coefficient values are downloaded from the host before commencing a move. For a load that varies during a movement more coefficients can be downloaded and used to update the PID filter at the moment the load changes. All trajectory parameters except acceleration can also be updated while a movement is in progress.

2.0 Device Description

2.1 HARDWARE ARCHITECTURE

Four major functional blocks make up the LM628/629 in addition to the host and output interfaces. These are the Trajectory Profile Generator, Loop Compensating PID Filter, Summing Junction and Motor Position Decoder (*Figure 1*).

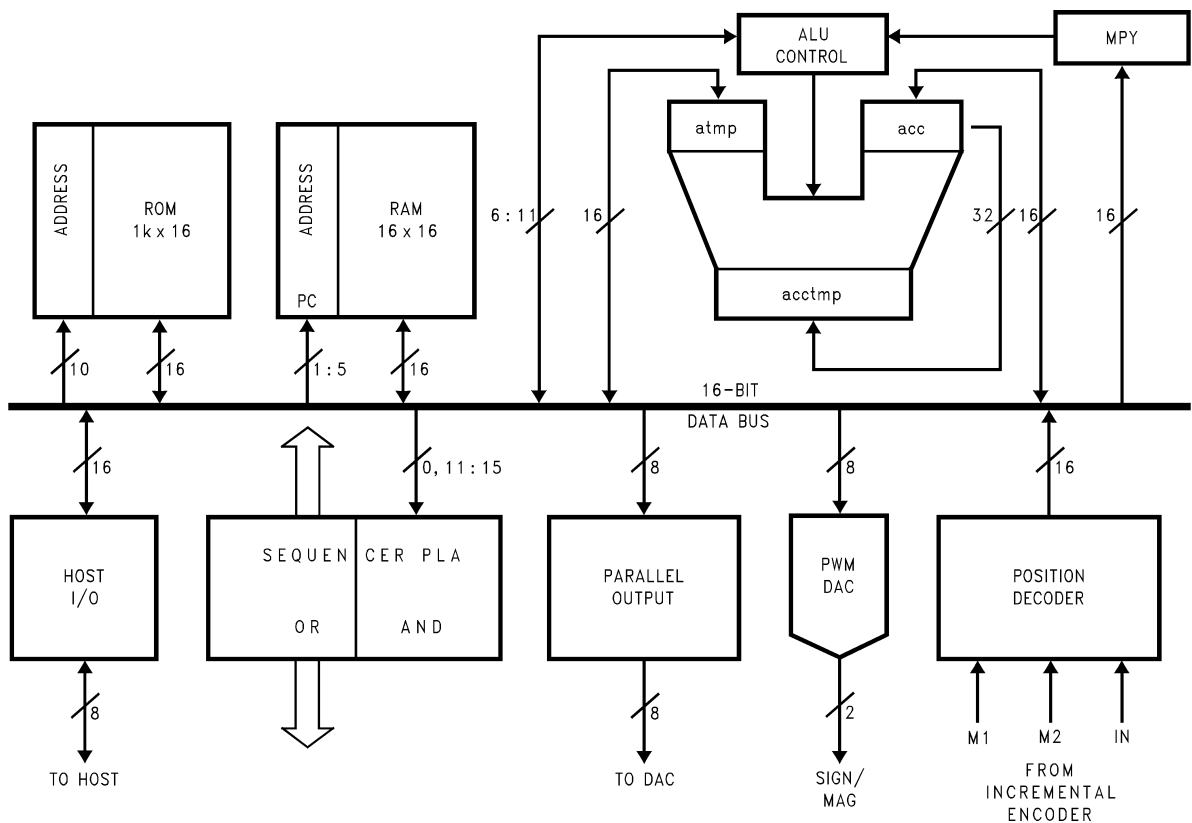

01101802

FIGURE 2. Hardware Architecture of LM628/629

Details of how LM628/629 is implemented by a purpose designed microcontroller are shown in *Figure 2*. The control algorithm is stored in a 1k x 16-bit ROM and uses 16-bit wide instructions. A PLA decodes these instructions and provides data transfer timing signals for the single 16-bit data and instruction bus. User variable filter and trajectory profile parameters are stored as 32-bit double words in RAM. To provide sufficient dynamic range a 32-bit position register is used and for consistency. 32 bits are also used for velocity and acceleration values. A 32-bit ALU is used to support the 16 x 16-bit multiplications of the error and PID digital filter coefficients.

2.2 MOTOR POSITION DECODER

LM628/629 provides an interface for an optical position shaft encoder, decoding the two quadrature output signals to provide position and direction information, *Figure 3*. Optionally a third index position output signal can be used to capture position once per revolution. Each of the four states of the quadrature position signal are decoded by the LM628/629 giving a 4 times increase in position resolution over the number of encoder lines. An "N" line encoder will be decoded as "4N" position counts by LM628/629.

2.0 Device Description (Continued)

Position decoder block diagram, *Figure 4*, shows three lines coming from the shaft encoder, M1, M2 and Index. From these the decoder PLA determines if the motor has moved forward, backward or stayed still and then drives a 16-bit

up-down counter that keeps track of actual motor position. Once per revolution when all three lines including the index line are simultaneously low, *Figure 3*, the current position count is captured in an index latch.

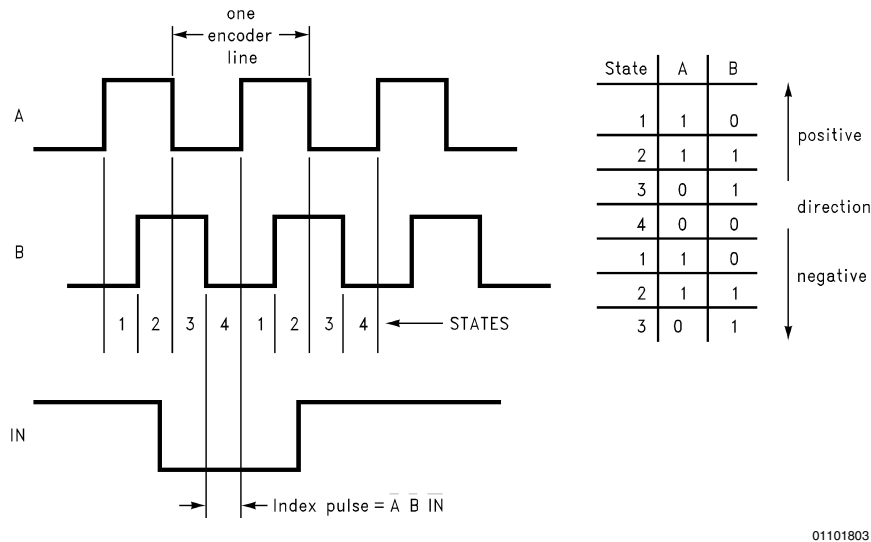

01101803

FIGURE 3. Quadrature Encoder Output Signals and Direction Decode Table

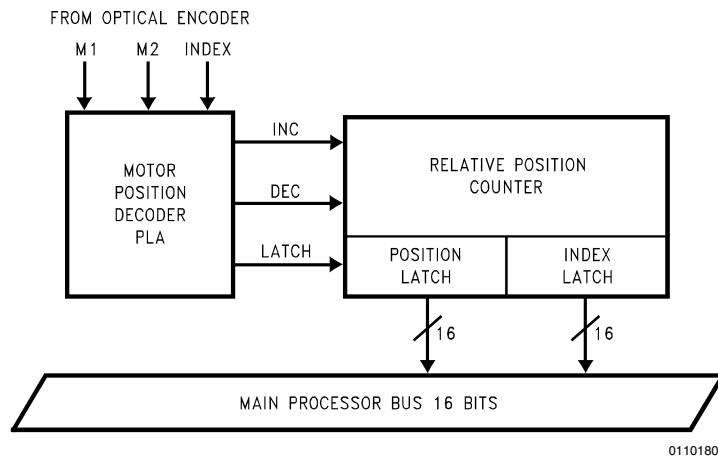

01101804

FIGURE 4. LM628/629 Motor Position Decoder

The 16-bit up-down counter is used to capture the difference in position from one sample to the next. A position latch attached to the up-down counter is strobed at the same time in every sample period by a sync pulse that is generated in hardware. The position latch is read soon after the sync pulse and is added to the 32-bit position register in RAM that holds the actual current position. This is the value that is subtracted in the summing junction every sample interval from the new desired position calculated by the trajectory generator to form the error input to the PID filter.

Maximum encoder state capture rate is determined by the minimum number of clock cycles it takes to decode each encoder state, see *Figure 3*, this minimum number is 8 clock

cycles, capture of the index pulse is also achieved during these 8 clock cycles. This gives a more than adequate 1 MHz maximum encoder state capture rate with the 8 MHz f_{CLK} devices (750 kHz for the 6 MHz f_{CLK} devices). For example, with the 1 MHz capture rate, a motor using a 500 line encoder will be moving at 30,000 rpm.

There is some limited signal conditioning at the decoder input to remove problems that would occur due to the asynchronous position encoder input being sampled on signal edges by the synchronous LM628/629. But there is no noise filtering as such on the encoder lines so it is important that they are kept clean and away from noise sources.

2.0 Device Description (Continued)

2.3 TRAJECTORY PROFILE GENERATOR

Desired position inputs to the summing junction, *Figure 1*, within the LM628/629 are provided by an internal independent trajectory profile generator. The trajectory profile generator takes information from the host and computes for each sample interval a new current desired position. The information required from the host is, operating mode, either position or velocity, target acceleration, target velocity and target position in position mode.

2.4 DEFINITIONS RELATING TO PROFILE GENERATION

The units of position and time, used by the LM628/629, are counts ($4 \times N$ encoder lines) and samples (sample intervals = $2048/f_{CLK}$) respectively. Velocity is therefore calculated in counts/sample and acceleration in counts/sample/sample.

Definitions of “target”, “desired” and “actual” within the profile generation activity as they apply to velocity, acceleration and position are as follows. Final requested values are called “target”, such as target position. The values computed by the profile generator each sample interval on the way to the target value are called “desired”. Real values from the position encoder are called “actual”.

For example, the current actual position of the motor will typically be a few counts away from the current desired

position because a new value for desired position is calculated every sample interval during profile generation. The difference between the current desired position and current actual position relies on the ability of the control loop to keep the motor on track. In the extreme example of a locked rotor there could be a large difference between the current actual and desired positions.

Current desired velocity refers to a fixed velocity at any point on a on-going trajectory profile. While the profile demands acceleration, from zero to the target velocity, the velocity will incrementally increase at each sample interval.

Current actual velocity is determined by taking the difference in the actual position at the current and the previous sample intervals. At velocities of many counts per sample this is reasonably accurate, at low velocities, especially below one count per sample, it is very inaccurate.

3.0 Profile Generation

Trajectory profiles are plotted in terms of velocity versus time, *Figure 5*, and are velocity profiles by reason that a new desired position is calculated every sample interval. For constant velocity these desired position increments will be the same every sample interval, for acceleration and deceleration the desired position increments will respectively increase and decrease per sample interval. Target position is the integral of the velocity profile.

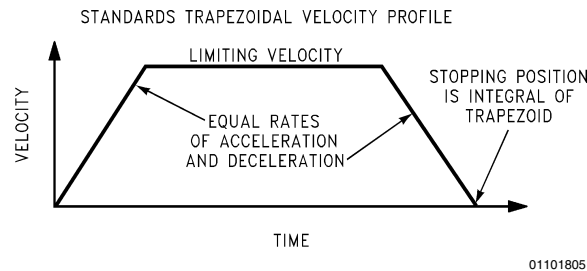

FIGURE 5. Typical Trajectory Velocity Profile

When performing a move the LM628/629 uses the information as specified by the host and accelerates until the target velocity is reached. While doing this it takes note of the number of counts taken to reach the target velocity. This number of counts is subtracted from the target position to determine where deceleration should commence to ensure the motor stops at the target position. LM628/629 deceleration rates are equal to the acceleration rates. In some cases, depending on the relative target values of velocity, acceleration and position, the target velocity will not be reached and deceleration will commence immediately from acceleration.

3.1 TRAJECTORY RESOLUTION

The resolution the motor sees for position is one integral count. The algorithm used to calculate the trajectory adds the velocity to the current desired position once per sample period and produces the next desired position point. In order to allow very low velocities it is necessary to have velocities of fractional counts per sample. The LM628/629 in addition to the 32-bit position range keeps track of 16 bits of fractional position. The need for fractional velocity counts can be illustrated by the following example using a 500 line (2000 count) encoder and an 8 MHz clock LM628/629 giving a 256 μ s sample interval. If the smallest resolution is 1 count per

sample then the minimum velocity would be 2 revolutions per second or 120 rpm. ($1/2000$ revs/count \times $1/256$ μ s counts/second). Many applications require velocities and steps in velocity less than this amount. This is provided by the fractional counts of acceleration and velocity.

3.2 POSITION, VELOCITY AND ACCELERATION RESOLUTION

Every sample cycle, while the profile demands acceleration, the acceleration register is added to the velocity register which in turn is added to the position register. When the demand for increasing acceleration stops, only velocity is added to the position register. Only integer values are output from the position register to the summing junction and so fractional position counts must accumulate over many sample intervals before an integer count is added and the position register changed. *Figure 6* shows the position, velocity and acceleration registers.

The position dynamic range is derived from the 32 bits of the integer position register, *Figure 6*. The MSB is used for the direction sign in the conventional manner, the next bit 30 is used to signify when a position overflow called “wraparound” has occurred. If the wraparound bit is set (or reset when

3.0 Profile Generation (Continued)

going in a negative direction) while in operation the status byte bit 4 is set and optionally can be used to interrupt the host. The remaining 30 bits provide the available dynamic range of position in either the positive or negative direction ($\pm 1,073,741,824$ counts).

Velocity has a resolution of $1/2^{16}$ counts/sample and acceleration has a resolution of $1/2^{16}$ counts/sample/sample as mentioned above. The dynamic range is 30 bits in both cases. The loss of one bit is due to velocity and acceleration being unsigned and another bit is used to detect wrap-around. This leaves 14 bits or 16,383 integral counts and 16 bits for fractional counts.

3.3 VELOCITY MODE

LM628 supports a velocity mode where the motor is commanded to continue at a specified velocity, until it is told to stop (LTRJ bits 9 or 10). The average velocity will be as specified but the instantaneous velocity will vary. Velocities of fractional counts per sample will exhibit the poorest instantaneous velocity. Velocity mode is a subset of position mode where the position is continually updated and moved ahead of the motor without a specified stop position. Care should be exercised in the case where a rotor becomes locked while in velocity mode as the profile generator will continue to advance the position. When the rotor becomes free high velocities will be attained to catch-up with the current desired position.

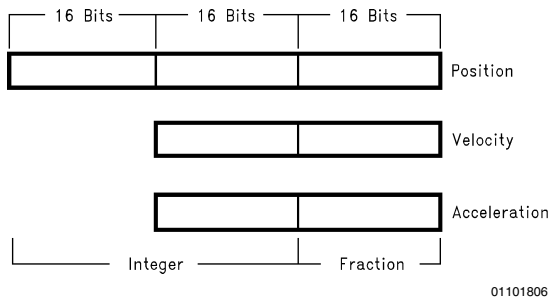

01101806

FIGURE 6. Position, Velocity and Acceleration Registers

3.4 MOTOR OUTPUT PORT

LM628 output port is configured to 8 bits after reset. The 8-bit output is updated once per sample interval and held until it is updated during the next sample interval. This allows use of a DAC without a latch. For 12-bit operation the PORT12 command should be issued immediately after reset. The output is multiplexed in two 6-bit words using pins 18 through 23. Pin 24 is low for the least significant word and high for the most significant. The rising edge of the active low strobe from pin 25 should be used to strobe the output into an external latch, see *Figure 7*. The DAC output is offset binary code, the zero codes are hex'80' for 8 bits and hex'800' for 12 bits.

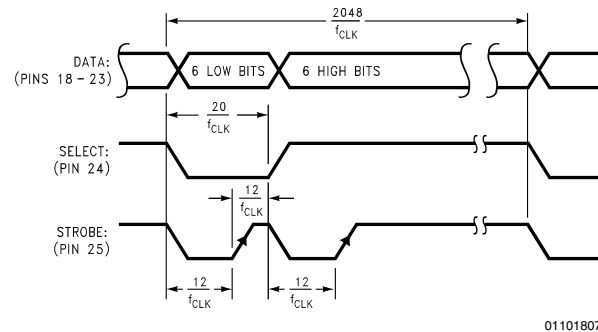

01101807

FIGURE 7. LM628 12-Bit DAC Output Multiplexed Timing

The choice of output resolution is dependant on the user's application. There is a fundamental trade-off between sampling rate and DAC output resolution, the LM628 8-bit output at a 256 μ s sampling interval will most often provide as good results as a slower, e.g. microcontroller, implementation which has a 4 ms typical sampling interval and uses a 12-bit output. The LM628 also gives the choice of a 12-bit DAC output at a 256 μ s sampling interval for high precision applications.

LM629 PWM sign and magnitude signals are output from pins 18 and 19 respectively. The sign output is used to control motor direction. The PWM magnitude output has a resolution of 8 bits from maximum negative drive to maximum positive drive. The magnitude output has an off condition, with the output at logic low, which is useful for turning a motor off when using a bridge motor drive circuit. The minimum duty cycle is 1/128 increasing to a maximum of 127/128 in the positive direction and a maximum of 128/128 in the negative direction, i.e., a continuous output. There are four PWM periods in one LM629 sample interval. With an 8 MHz clock this increases the PWM output rate to 15.6 kHz from the LM629 maximum 3.9 kHz sample rate, see *Figure 8* for further timing information.

3.0 Profile Generation (Continued)

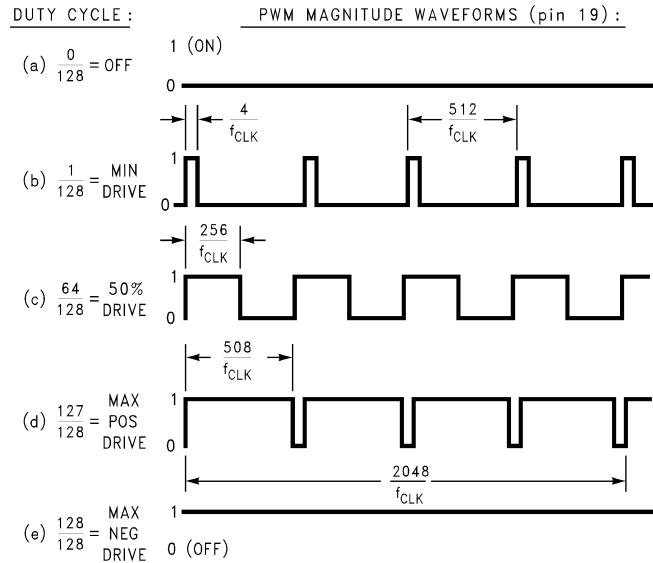

Note: Sign output (pin 18) not shown.

FIGURE 8. LM629 PWM Output Signal Format

3.5 HOST INTERFACE

LM628/629 has three internal registers: status, high, and low bytes, *Figure 9*, which are used to communicate with the host microcontroller. These are controlled by the $\overline{\text{RD}}$, $\overline{\text{WR}}$, and $\overline{\text{PS}}$ lines and by use of the busy bit of the status byte. The status byte is read by bringing $\overline{\text{RD}}$ and $\overline{\text{PS}}$ low, bit 0 is the busy bit. Commands are written by bringing $\overline{\text{WR}}$ and $\overline{\text{PS}}$ low. When $\overline{\text{PS}}$ is high, $\overline{\text{WR}}$ brought low writes data into LM628/629 and similarly, $\overline{\text{RD}}$ is brought low to read data from LM628/629. Data transfer is a two-byte operation written in most to least significant byte order. The above description assumes that $\overline{\text{CS}}$ is low.

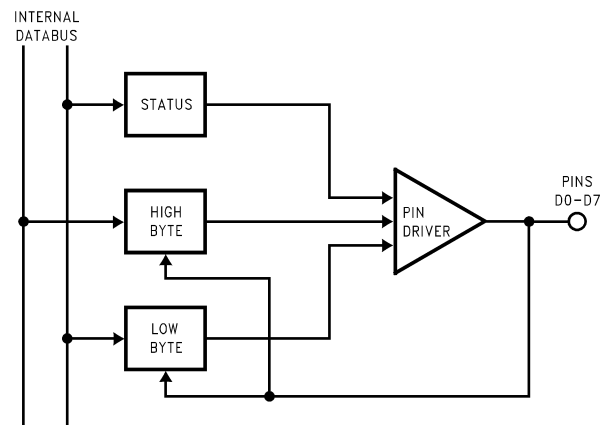

FIGURE 9. Host Interface Internal I/O Registers

3.6 HARDWARE BUSY BIT OPERATION

Before and between all command byte and data byte pair transfers, the busy bit must be read and checked to be at logic low. If the busy bit is set and commands are issued they will be ignored and if data is read it will be the current contents of the I/O buffer and not the expected data. The busy bit is set after the rising edge of the write signal for commands and the second rising edge of the respective read or write signal for two byte data transfers, *Figure 10*. The busy bit remains high for approximately 15 μs .

3.0 Profile Generation (Continued)

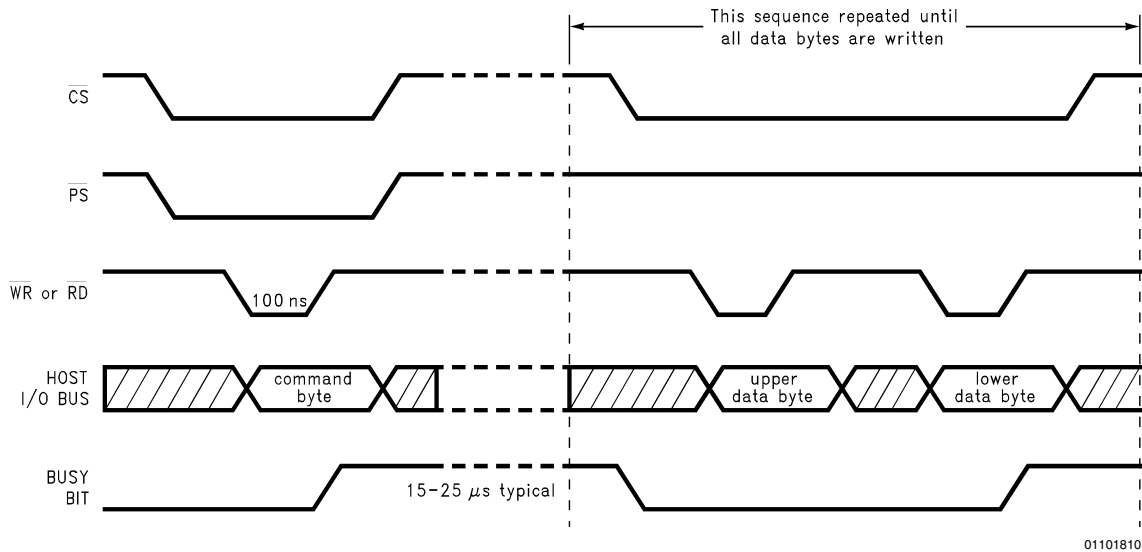

FIGURE 10. Busy Bit Operation during Command and Data Write Sequence

The busy bit reset to logic low indicates that high and low byte registers shown in *Figure 9* have been either loaded or read by the LM628/629 internal microcode. To service the command or data transfer this microcode which performs the trajectory and filter calculations is interrupted, except in critical areas, and the on-going calculation is suspended. The microcode was designed this way to achieve minimum latency when communicating with the host. However, if this communication becomes too frequent and on-going calculations are interrupted too often corruption will occur. In a 256 μs sample interval, the filter calculation takes 50 μs , outputting a sample 10 μs and trajectory calculation 90 μs . If the LM628 behaves in a manner that is unexpected the host communication rate should be checked in relation to these timings.

3.7 FILTER INITIAL VALUES AND TUNING

When connecting up a system for the first time there may be a possibility that the loop phasing is incorrect. As this may cause violent oscillation it is advisable to initially use a very low value of proportional gain, say $k_p = 1$ (with k_d , k_i and i_l all set to zero), which will provide a weak level of drive to the motor. (The Start command, STT, is sent to LM628/629 to close the control loop and energize the motor.) If the system does oscillate with this low value of k_p then the motor connections should be reversed.

Having determined that the loop phasing is correct k_p can be increased to a value of about 20 to see that the control system basically works. This value of k_p should hold the motor shaft reasonably stiffly, returning the motor to the set position, which will be zero until trajectory values have been input and a position move performed. If oscillation or unacceptable ringing occurs with a k_p value of 20 reduce this until it stops. Low values of acceleration and velocity can now be input, of around 100, and a position move commanded to say 1000 counts. All values suggested here are decimal. For details of loading trajectory and filter parameters see Section 3.0, reference (5) and the data sheet.

It is useful at this stage to try different values of acceleration and velocity to get a feel for the system limitations. These can be determined by using the reporting commands of desired and actual position and velocity, to see if the error between desired and actual positions of the motor are constant and not increasing without bound. See Section 3.6 and the data sheet for information about the reporting commands. Clearly it will be difficult to tune for best system response if the motor and its load cannot achieve the demanded values of acceleration and velocity. When correct operation is confirmed and limiting values understood, filter tuning can commence.

Due to the basic difficulty of accurately modeling a control system, with the added problem of variations that can occur in mechanical components over time and temperature, it is always necessary at some stage to perform tuning empirically. Determining the PID filter coefficients by tuning is the preferred method with LM628/629 because of the inherent flexibility in changing the filter coefficients provided by this programmable device.

Before tuning a control system the effect of each of the PID filter coefficients should be understood. The following is a very brief review, for a detailed understanding reference (2) should be consulted. The proportional coefficient, k_p , provides adjustment of the control system loop proportional gain, as this is increased the output steady state error is reduced. The error between the required and actual position is effectively divided by the loop gain. However there is a natural limitation on how far k_p can be increased on its own to reduce output position error because a reduction in phase margin is also a consequence of increasing k_p . This is first encountered as ringing about the final position in response to a step change input and then instability in the form of oscillation as the phase margin becomes zero. To improve stability, k_d , the derivative coefficient, provides a damping effect by providing a term proportional to velocity in an-

3.0 Profile Generation (Continued)

tiphase to the ringing, or viewed in another way, adds some leading phase shift into the loop and increases the phase margin.

In the tuning process the coefficients k_p and k_d are iteratively increased to their optimum values constrained by the system constants and are trade-offs between response time, stability and final position error. When k_p and k_d have been determined the integral coefficient, k_i , can be introduced to remove steady state errors at the load. The steady state errors removed are the velocity lag that occurs with a constant velocity output and the position error due to a constant static torque. A value of integration limit, i_l , has to be input with k_i , otherwise k_i will have no effect. The integral coefficient k_i adds another variable to the system to allow further optimization, very high values of k_i will decrease the phase margin and hence stability, see Section 5 and reference (2) for more details. Reference (5) gives more details of PID filter tuning and how to load filter parameters.

Figure 11 illustrates how a relatively slow response with overshoot can be compensated by adjustment of the PID filter coefficients to give a faster critically damped response.

4.0 User Command Set

4.1 OVERVIEW

The following types of User Commands are available:

Initialization

Filter control commands

Trajectory control commands

Interrupt control commands

Data reporting commands

User commands are single bytes and have a varying number of accompanying data bytes ranging from zero to fourteen depending upon the command. Both filter and trajectory control commands use a double buffered scheme to input data. These commands load primary registers with multiple words of data which are only transferred into secondary working registers when the host issues a respective single byte user command. This allows data to be input before its actual use which can eliminate any potential communication bottlenecks and allow synchronized operation of multiple axes.

4.2 HOST-LM628/629 COMMUNICATION—THE BUSY BIT

Communication flow between the LM628/629 and its host is controlled by using a busy bit, bit 0, in the Status Byte. The busy bit must be checked to be at logic 0 by the host before commands and data are issued or data is read. This includes between data byte pairs for commands with multiple words of data.

4.3 LOADING THE TRAPEZOIDAL VELOCITY PROFILE GENERATOR

To initiate a motor move, trajectory generator values have to be input to the LM628/629 using the Load Trajectory Parameters, LTRJ, command. The command is followed by a tra-

jectory control word which details the information to be loaded in subsequent data words. Table 1 gives the bit allocations, a bit is set to logic 1 to give the function shown.

TABLE 1. Trajectory Control Word Bit Allocations

Bit Position	Function
Bit 15	Not Used
Bit 14	Not Used
Bit 13	Not Used
Bit 12	Forward Direction (Velocity Mode Only)
Bit 11	Velocity Mode
Bit 10	Stop Smoothly (Decelerate as Programmed)
Bit 9	Stop Abruptly (Maximum Deceleration)
Bit 8	Turn Off Motor (Output Zero Drive)
Bit 7	Not Used
Bit 6	Not Used
Bit 5	Acceleration Will Be Loaded
Bit 4	Acceleration Data Is Relative
Bit 3	Velocity Will Be Loaded
Bit 2	Velocity Data Is Relative
Bit 1	Position Will Be Loaded
Bit 0	Position Data Is Relative

Bits 0 to 5 determine whether any, all or none of the position, velocity or acceleration values are loaded and whether they are absolute values or values relative to those previously loaded. All trajectory values are 32-bit values, position values are both positive and negative. Velocity and acceleration are 16-bit integers with 16-bit fractions whose absolute value is always positive. When entering relative values ensure that the absolute value remains positive. The manual stop commands bits 8, 9 and 10 are intended to allow an unprogrammed stop in position mode, while a position move is in progress, perhaps by the demand of some external event, and to provide a method to stop in velocity mode. They do not specify how the motor will stop in position mode at the end of a normal position move. In position mode a programmed move will automatically stop with a deceleration rate equal to the acceleration rate at the target position. Setting a stop bit along with other trajectory parameters at the beginning of a move will result in no movement! Bits 8, 9 and 10 should only be set one at a time, bit 8 turns the motor off by outputting zero drive to the motor, bit 9 stops the motor at maximum deceleration by setting the target position equal to the current position and bit 10 stops the motor using the current user-programmed acceleration value. Bit 11 is set for operating in velocity mode and bit 12 is set for forward direction in velocity mode.

4.0 User Command Set (Continued)

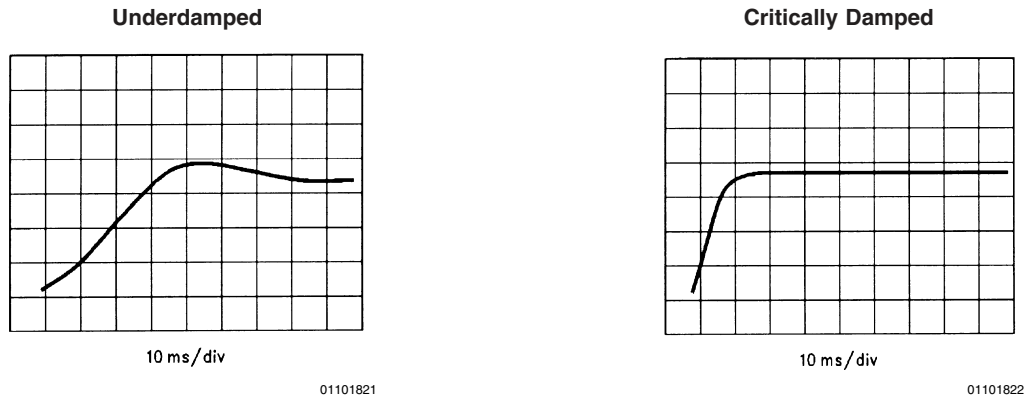

FIGURE 11. Position vs Time for 100 Count Step Input

Following immediately after the trajectory control word should be two 16-bit data words for each parameter specified to be loaded. These should be in the descending order of the trajectory control word bits, that is acceleration, velocity and position. They are written to the LM628/629 as two pairs of data bytes in most to least significant byte order. The busy bit should be checked between the command byte and the data byte pair forming the trajectory control word and the individual data byte pairs of the data. The Start command, STT, transfers the loaded trajectory data into the working registers of the double buffered scheme to initiate movement of the motor. This buffering allows any parameter, except acceleration, to be updated while the motor is moving by loading data with the LTRJ command and to be later executed by using the STT command.

New values of acceleration can be loaded with LTRJ while the motor is moving, but cannot be executed by the STT command until the trajectory has completed or the drive to the motor is turned off by using bit 8 of the trajectory control word. If acceleration has been changed and STT is issued while the drive to the motor is still present, a command error interrupt will be generated and the command ignored. Separate pairs of LTRJ and STT commands should be issued to first turn the motor off and then update acceleration. System operation when changing acceleration while the motor is moving, but with the drive removed, is discussed in Section 4.5.1.

4.4 LOADING PID FILTER COEFFICIENTS

PID filter coefficients are loaded using the Load Filter Parameters, LFIL, command and are the proportional coefficient k_p , derivative coefficient k_d and integral coefficient k_i . Associated with k_i , an integration limit, il , has to be loaded. This constrains the magnitude of the integration term of the PID filter to the il value, see Section 4.4.2. Associated with the derivative coefficient, a derivative sample rate can be chosen from $2048/f_{CLK}$ to $(2048 \times 256)/f_{CLK}$ in steps of $2048/f_{CLK}$, see Section 4.4.1.

The first pair of data bytes following the LFIL command byte form the filter control word. The most significant byte sets the derivative sample rate, the fastest rate, $2048/f_{CLK}$, being hex'00' the slowest rate $(2048 \times 256)/f_{CLK}$ being hex'FF'. The lower four bits of the least significant byte tell the LM628/629 which of the coefficients is going to be loaded, bit 3 is k_p , bit

2 is k_i , bit 1 is k_d and bit 0 is il . Each filter coefficient and the integration limit can range in value from hex'0000' to '7FFF', positive only. If all coefficient values are loaded then ten bytes of data, including the filter control word, will follow the LFIL command. Again the busy bit has to be checked between the command byte and filter control word and between data byte pairs. Use of new filter coefficient values by the LM628/629 is initiated by issuing the single byte Update Filter command, UDF.

When controlled movement of the motor has been achieved, by programming the filter and trajectory, attention turns to incorporating the LM628/629 into a system. Interrupt Control Commands and Data Reporting Commands enable the host microcontroller to keep track of LM628/629 activity.

4.5 INTERRUPT CONTROL COMMANDS

There are five commands that can be used to interrupt the host microcontroller when a predefined condition occurs and two commands that control interrupt operation. When the LM628/629 is programmed to interrupt its host, the event which caused this interrupt can be determined from bits 1 to 6 of the Status Byte (additionally bit 0 is the busy bit and bit 7 indicates that the motor is off). All the Interrupt Control commands are executable during motion.

The Mask Interrupts command, MSKI, is used to tell LM628/629 which of bits 1 to 6 will interrupt the host through use of interrupt mask data associated with the command. The data is in the form of a data byte pair, bits 1–6 of the least significant byte being set to logic 1 when an interrupt source is enabled. The Reset Interrupts command, \overline{RSTI} , resets interrupt bits in the Status Byte by sending a data byte pair, the least significant byte having logic 0 in bit positions 1 to 6 if they are to be reset.

Executing the Set Index Position command, SIP, causes bit 3 of the status byte to be set when the absolute position of the next index pulse is recorded in the index register. This can be read with the command, Read Index Position, RDIP.

Executing either Load Position Error for Interrupt, LPEI, or Load Position Error for Stopping, LPES, commands, sets bit 5 of the Status Byte when a position error exceeding a specified limit occurs. An excessive position error can indicate a serious system problem and these two commands give the option when this occurs of either interrupting the

4.0 User Command Set (Continued)

host or stopping the motor and interrupting the host. The excessive position is specified following each command by a data byte pair in most to least significant byte order.

Executing either Set Break Point Absolute, SBPA, or Set Break Point Relative, SBPR, commands, sets bit 6 of the status byte when either the specified, absolute or relative, breakpoint respectively is reached. The data for SBPA can be the full position range (hex'C0000000' to '3FFFFFFF') and is sent in two data byte pairs in most to least significant byte order. The data for the Set Breakpoint Relative command is also of two data byte pairs, but its value should be such that when added to the target position it remains within the absolute position range. These commands can be used to signal the moment to update the on-going trajectory or filter coefficients. This is achieved by transferring data from the primary registers, previously loaded using LTRJ or LFIL, to working registers, using the STT or UDF commands.

Interrupt bits 1, 2 and 4 of the Status Byte are not set by executing interrupt commands but by events occurring during LM628/629 operation as follows. Bit 1 is the command error interrupt, bit 2 is the trajectory complete interrupt and bit 4 is the wraparound interrupt. These bits are also masked and reset by the MSKI and RSTI commands respectively. The Status Byte still indicates the condition of interrupt bits 1–6 when they are masked from interrupting the host, allowing them to be incorporated in a polling scheme.

4.6 DATA REPORTING COMMANDS

Read Status Byte, RDSTAT, supported by a hardware register accessed via \overline{CS} , \overline{RD} and \overline{PS} control, is the most frequently used method of determining LM628/629 status. This is primarily to read the busy bit 0 while communicating commands and data as described in Section 3.2.

There are seven other user commands which can read data from LM628/629 data registers.

The Read Signals Register command, RDSIGS, returns a 16-bit data word to the host. The least-significant byte repeats the RDSTAT byte except for bit 0 which indicates that

```

LABEL   MNEMONIC           :REMARK
Initialization:
        WAIT                :Routine to wait 1.5 ms after reset.
        RDSTAT              :Check correct RESET operation by reading the
                           :Status Byte. This should be either hex'84' or 'C4'
        IF Status byte not equal hex'84' or 'C4' THEN repeat
        hardware RESET
                           :Make decision concerning validity of RESET

```

Optionally the Reset can be further checked for correct operation as follows. It is useful to include this to reset all interrupt bits in the Status Byte before further action:

```

        MSKI                :Mask interrupts
        BUSY                :Check busy bit 0 routine
        WR, 0000H           :Host writes two zero bytes of data to
                           :LM628/629. This mask disables all interrupts.
        BUSY                :Check busy bit
        RSTI                :Reset Interrupts command
        BUSY                :Check busy bit
        WR, 0000H           :Host writes two zero bytes of data to LM628/629
        RDSTAT              :Status byte should read either hex'80' or 'C0'
        IF Status Byte not equal hex'80' or 'C0' THEN repeat
        hardware RESET
        :
        IF Status Byte equal to hex'C0' THEN continue ELSE PORT
        :
        BUSY                :Check busy bit

```

a SIP command has been executed but that an index pulse has not occurred. The most significant byte has 6 bits that indicate set-up conditions (bits 8, 9, 11, 12, 13 and 14). The other two bits of the RDSIGS data word indicate that the trajectory generator has completed its function, bit 10, and that the host interrupt output (Pin 17) has been set to logic 1, bit 15. Full details of the bit assignments of this command can be found in the data sheet.

The Read Index Position, RDIP, command reads the position recorded in the 32 bits of the index register in four data bytes. This command, with the SIP command, can be used to acquire a home position or successive values. These could be used, for example, for gross error checking.

Both on-going 32-bit position inputs to the summing junction can be read. Read desired position, RDDP, reads the current desired position the demand or "set point input" from the trajectory generator and Read Real Position, RDRP, reads the current actual position of the motor.

Read Desired Velocity, RDDV, reads the current desired velocity used to calculate the desired position profile by the trajectory generator. It is a 32-bit value containing integer and fractional velocity information. Read Real Velocity, RDRV, reads the instantaneous actual velocity and is a 16-bit integer value.

Read Integration-Term Summation Value, RDSUM, reads the accumulated value of the integration term. This is a 16-bit value ranging from zero to the current, i_l , integration limit value.

4.7 SOFTWARE EXAMPLE

The following example shows the flow of microcontroller commands needed to get the LM628/629 to control a simple motor move. As it is non-specific to any microcontroller pseudo commands $\overline{WR},XXXXH$ and $\overline{RD},XXXXH$ with hex immediate data will be used to indicate read and write operations respectively by the host to and from the LM628/629. Decisions use IF..THEN..ELSE. BUSY is a user routine to check the busy bit in the Status Byte, WAIT is a user routine to wait 1.5 ms after hardware reset.

4.0 User Command Set (Continued)

```

RSTI          :Reset Interrupts
BUSY          :Check busy bit
WR, 0000H    :Reset all interrupt bits
Set Output Port Size for a 12-bit DAC.
PORT         BUSY          :Check busy bit
            PORT12       :Sets LM628 output port to 12-bits
                        (Only for systems with 12-bit DAC)

Load Filter Parameters
BUSY          :Check busy bit
LFIL         :Load Filter Parameters command
BUSY          :Check busy bit
WR, 0008H    :Filter Control Word
            :   Bits 8 to 15 (MSB) set the derivative
            :sample rate.
            :   Bit 3   Loading kp data
            :   Bit 2   Loading ki data
            :   Bit 1   Loading kd data
            :   Bit 0   Loading il data
            :Choose to load kp only at maximum
            :derivative sample rate then Filter Control
            :Word = 0008H
BUSY          :Check busy bit
WR, 0032H    :Choose kp = 50, load data byte pair MS
            :byte first

Update Filter
BUSY          :Check busy bit
UDF          :

Load Trajectory Parameters
BUSY          :Check busy bit
LTRJ         :Load trajectory parameters command.
BUSY          :Check busy bit
WR, 002AH    :Load trajectory control word:
            :   See Table I
            :Choose Position mode, and load absolute
            :acceleration, velocity and position. Then
            :trajectory control word = 002AH. This means
            :6 pairs of data bytes should follow.
BUSY          :Check busy bit
WR, XXXXH    :Load Acceleration integer word MS byte first
BUSY          :Check busy bit
WR, XXXXH    :Load Acceleration fractional word MS byte first
BUSY          :Check busy bit
WR, XXXXH    :Load Velocity integer word MS byte first
BUSY          :Check busy bit
WR, XXXXH    :Load Velocity fractional word MS byte first
BUSY          :Check busy bit

WR, XXXXH    :Load Position MS byte pair first
BUSY          :Check busy bit
WR, XXXXH    :Load position LS byte pair

Start Motion
BUSY          :Check busy bit
STT          :Start command

Check for Trajectory complete.
RDSTAT       :Check Status Byte bit 2 for trajectory
            :complete

Busy bit check routine
BUSY         RDSTAT       :Read status byte
            If bit 0 is set THEN BUSY ELSE RETURN
            END

```

*Consult reference (5) for more information on programming the LM628/629.

4.0 User Command Set (Continued)

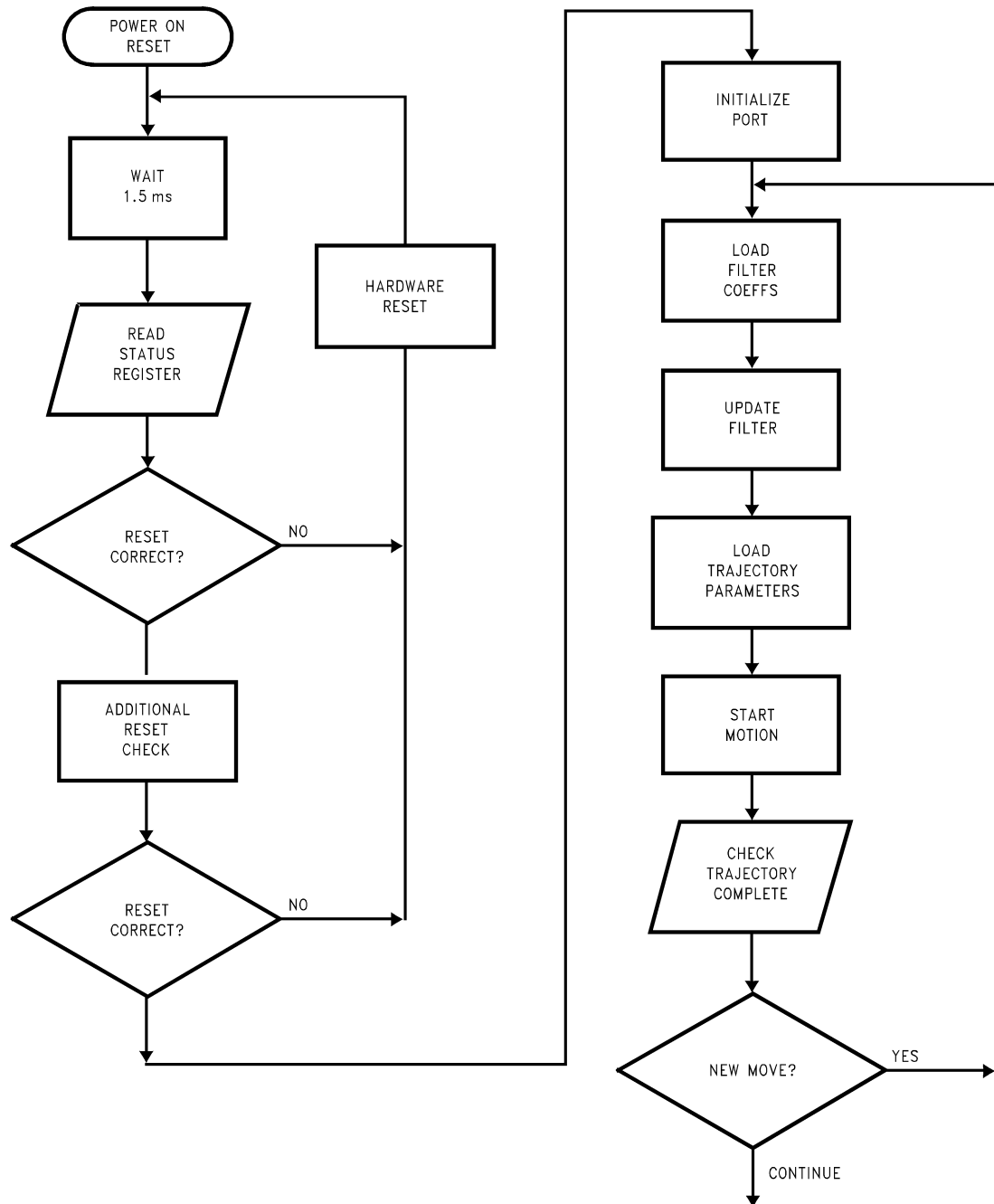

01101812

FIGURE 12. Basic Software Flow

5.0 Helpful User Ideas

5.1 GETTING STARTED

This section outlines the actions that are necessary to implement a simple motion control system using LM628/629. More details on how LM628/629 works and the use of the User Command Set are given in the sections "2.0 DEVICE DESCRIPTION" and "3.0 USER COMMAND SET".

5.2 HARDWARE

The following hardware connections need to be made:

5.2.1 Host Microcontroller Interface

Interface to the host microcontroller is via an 8-bit command/data port which is controlled by four lines. These are the conventional chip select \overline{CS} , read \overline{RD} , write \overline{WR} and a line called Port Select \overline{PS} , see *Figure 13*. \overline{PS} is used to select

5.0 Helpful User Ideas (Continued)

user Command or Data transfer between the LM628/629 and the host. In the special case of the Status Byte (RDSTAT) bringing PS, CS and RD low together allows access to this hardware register at any time. An optional interrupt line, HI, from the LM628/629 to the host can be used. A microcontroller output line is necessary to control the LM628/629 hardware reset action.

5.2.2 Position Encoder Interface

The two optical incremental position encoder outputs feed into the LM628/629 quadrature decoder TTL inputs A and B. The leading phase of the quadrature encoder output defines the forward direction of the motor and should be connected to input A. Optionally an index pulse may be used from the position encoder. This is connected to the IN input, which should be tied high if not used, see Figure 13.

5.2.3 Output Interface

LM628 has a parallel output of either 8 or 12 bits, the latter is output as two multiplexed 6-bit words. Figure 14 illustrates how a motor might be driven using a LM12 power linear amplifier from the output of 8-bit DAC0800.

LM629 has a sign and magnitude PWM output, Figure 13, of 7-bit resolution plus sign. Figure 15 shows how the LM629 sign and magnitude outputs can be used to control the outputs of an LM18293 quad half-H driver. The half-H drivers are used in pairs, by using 100 mΩ current sharing resistors, and form a full-H bridge driver of 2A output. The sign bit is used to steer the PWM LM629 magnitude output to either side of the H-bridge lower output transistors while holding the upper transistors on the opposite side of the H-bridge continuously on.

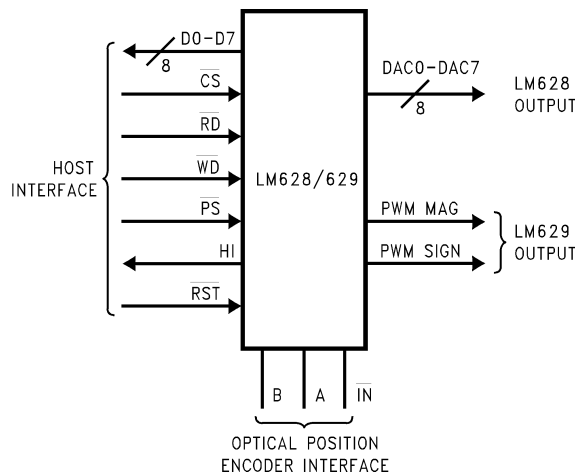

01101813

FIGURE 13. LM628 and LM629 Host, Output and Position Encoder Interfaces

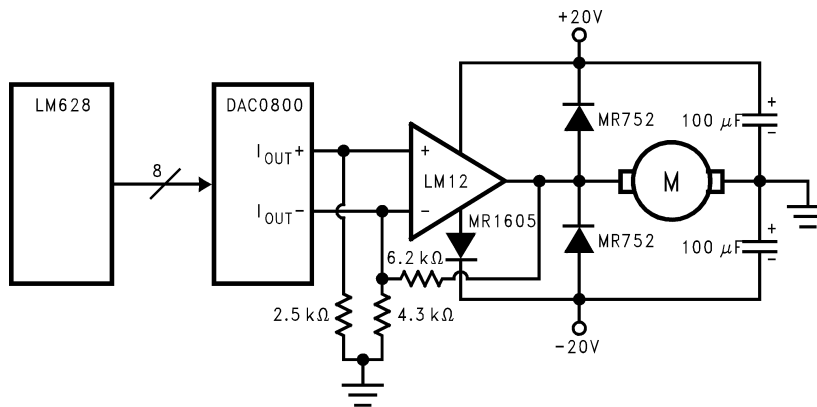

01101814

FIGURE 14. LM628 Example of Linear Motor Drive Using LM12

5.0 Helpful User Ideas (Continued)

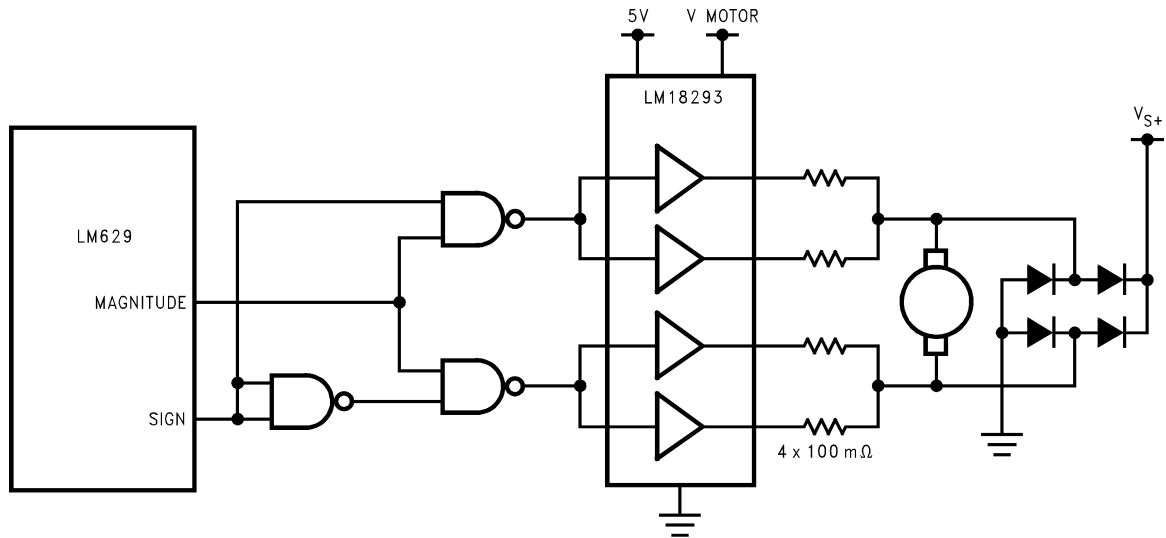

01101815

FIGURE 15. LM629 H-Bridge Motor Drive Example Using LM18293

5.3 SOFTWARE

Making LM628/629 perform a motion control function requires that the host microcontroller, after initializing LM628/629, loads coefficients for the PID filter and then loads trajectory information. The interrupt and data reporting commands can then be used by the host to keep track of LM628/629 actions. For detailed descriptions see the LM628/629 data sheet and Section 3.

5.4 INITIALIZATION

There is only one initialization operation that must be performed; a check that hardware reset has operated correctly. If required, the size of the LM628 output port should be configured. Other operations which might be part of user's system initialization are discussed under Interrupt and Data Reporting commands, Sections 3.5 and 3.6.

5.4.1 Initializing LM628 Output Port

Reset sets the LM628 output port size to 8 bits. If a 12-bit DAC is being used, then the output port size is set by the use of the PORT12 command.

5.4.2 Hardware RESET Check

The hardware reset is activated by a logic low pulse at pin 27, \overline{RST} , from the host of greater than 8 clock cycles. To ensure that this reset has operated correctly the Status Byte should be checked immediately after the reset pin goes high, it should read hex'00'. If the reset is successful this will change to hex'84' or 'C4' within 1.5 ms. If not, the hardware reset and check should be repeated. A further check can be used to make certain that a reset has been successful by using the Reset Interrupts command, RSTI. Before sending the RSTI, issue the Mask Interrupts command, MSKI, and mask data that disables all interrupts, this mask is sent as two bytes of data equaling hex'0000'. Then issue the RSTI command plus mask data that resets all interrupts, this equals hex'0000' and is again sent as two bytes. Do not

forget to check the busy bit between the command byte and data byte pairs. When the chip has reset properly the status byte will change from hex'84' or 'C4' to hex'80' or 'C0'.

5.4.3 Interrupt Commands

Optionally the commands which cause the LM628/629 to take action on a predefined condition (e.g., SIP, LPEI, LPES, SBPA and SBPR) can be included in the initialization, these are discussed under Interrupt Commands.

5.5 PERFORMANCE REFINEMENTS

5.5.1 Derivative Sample Rate

The derivative sample interval is controllable to improve the stability of low velocity, high inertia loads. At low speeds, when fractional counts for velocity are used, the integer position counts, desired and actual, only change after several sample intervals of the LM628/629 ($2048/f_{CLK}$). This means that for sample intervals between integer count changes the error voltage will not change for successive samples. As the derivative term, k_d , multiplies the difference between the previous and current error values, if the derivative sample interval is the same as the sample interval, several consecutive sample intervals will have zero derivative term and hence no damping contribution. Lengthening the derivative sample interval ensures a more constant derivative term and hence improved stability. Derivative sample interval is loaded with the filter coefficient values as the most significant byte of the LFIL control word everytime the command is used, the host therefore needs to store the current value for re-loading at times of filter coefficient change.

5.5.2 Integral Windup

Along with the integral filter coefficient, k_i , an integration limit, il , has to be input into LM628/629 which allows the user to set the maximum value of the integration term of equation (3), Section 5.2.2. This term is then able to accumulate up to

5.0 Helpful User Ideas (Continued)

the value of the integration limit and any further increase due to error of the same sign is ignored. Setting the integration limit enables the user to prevent an effect called “Integral Windup”. For example, if an LM628/629 attempts to accelerate a motor at a faster rate than it can achieve, a very large integral term will result. When the LM628/629 tries to stop the motor at the target position the large accumulated integral term will dominate the filter and cause the motor to badly overshoot, and thus integral windup has occurred.

5.5.3 Profiles Other Than Trapezoidal

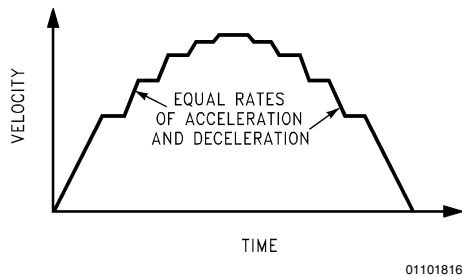

FIGURE 16. Generating a Non-Trapezoidal Profile

If it is required to have a velocity profile other than trapezoidal, this can be accomplished by breaking the profile into small pieces each of which is part of a small trapezoid. A piecewise linear approximation to the required profile can then be achieved by changing the maximum velocity before the trapezoid has had time to complete, see *Figure 16*.

5.5.4 Synchronizing Axes

For controlling tightly coupled coordinated motion between multiple-axes, synchronization is required. The best possible synchronization that can be achieved between multiple LM628/629 is within one sample interval, $(2048/f_{CLK})$, 256 μ s for an 8 MHz clock, 341 μ s for a 6 MHz clock). This is achieved by using the pipeline feature of the LM628/629 where all controlled axes are loaded individually with trajectory values using the LTRJ command and then simultaneously given the start command STT. PID filter coefficients can be updated in a similar manner using LFIL and UDF commands.

5.6 OPERATING CONSTRAINTS

5.6.1 Updating Acceleration on the Fly

Whereas velocity and target position can be updated while the motor is moving, on the “fly”, the algorithm described in Section 2.5 prevents this for acceleration. To change acceleration while the motor is moving in mid-trajectory the motor off command has to be issued by setting LTRJ command bit 8. Then the new acceleration can be loaded, again using the LTRJ command. When the start command STT is issued the motor will be energized and the trajectory generator will start generating a new profile from the actual position when the STT command was issued. In doing this the trajectory generator will assume that the motor starts from a stationary position in the normal way. If the motor has sufficient inertia and is still moving when the STT command is issued then the control loop will attempt to bring the motor on to the new profile, possibly with a large error value being input to the PID filter and a consequential saturated output until the motor velocity matches the profile. This is a classic case of overload in a feedback system. It will operate in an open loop manner until the error input gets within controllable bounds and then the feedback loop will close. Performance in this situation is unpredictable and application specific. LM628/629 was not intentionally designed to operate in this way.

5.6.2 Command Update Rate

If an LM628/629 is updated too frequently by the host it will not keep up with the commands given. The LM628/629 aborts the current trajectory calculation when it receives a new STT command, resulting in the output staying at the value of the previous sample. For this reason it is recommended that trajectory is not updated at a greater rate than once every 10 ms.

6.0 Theory

6.1 PID FILTER

6.1.1 PID Filter in the Continuous Domain

The LM628/629 uses a PID filter as the loop compensator, the expression for the PID filter in the continuous domain is:

$$H(s) = K_p + K_i / s + K_d s \quad (1)$$

Where K_p = proportional coefficient
 K_i = integral coefficient
 K_d = derivative coefficient

6.0 Theory (Continued)

6.1.2 PID Filter Bode Plots

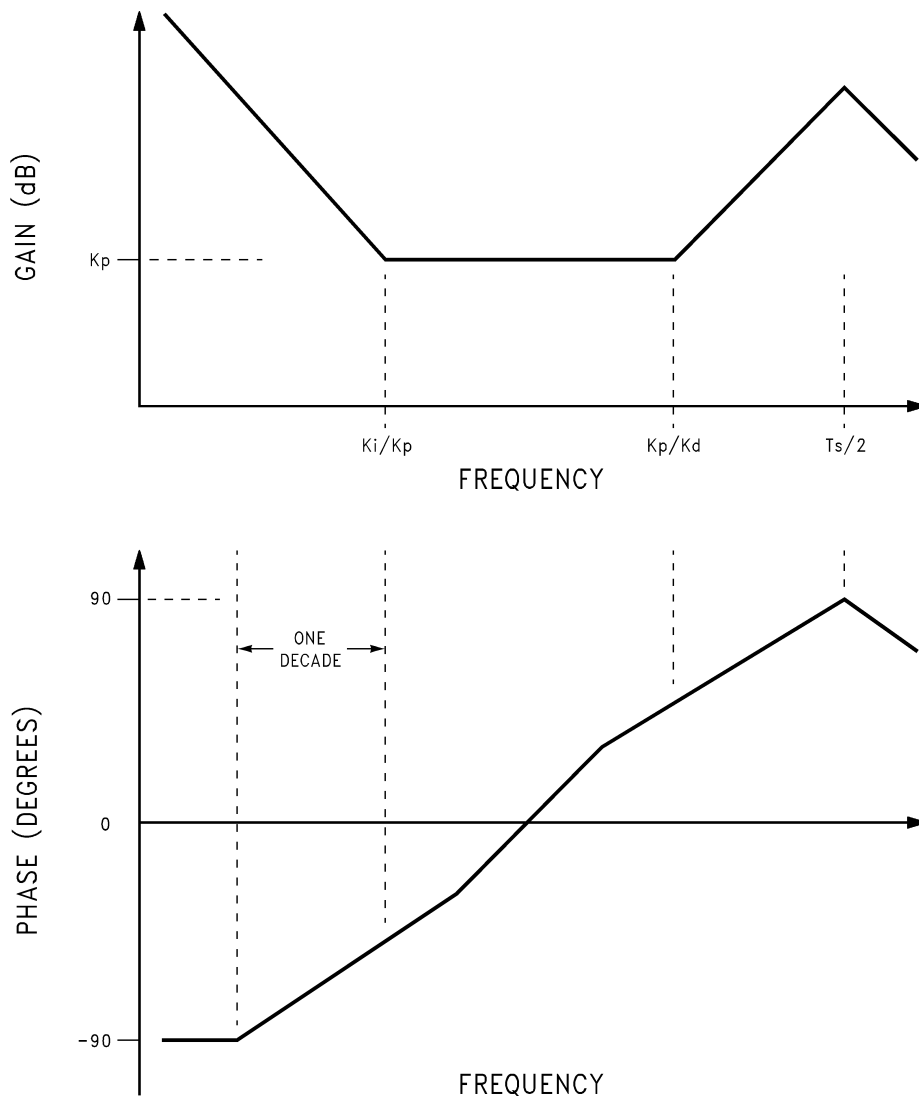

01101817

FIGURE 17. Bode Plots of PID Transfer Function

The Bode plots for this function (shown in *Figure 17*) show the effect of the individual terms of *Equation (1)*. The proportional term, K_p , provides adjustment of proportional gain. The derivative term K_d increases the system bandwidth but more importantly adds leading phase shift to the control loop at high frequencies. This improves stability by counteracting the lagging phase shift introduced by other control loop components such as the motor. The integral term, K_i , provides a high DC gain which reduces static errors, but introduces a lagging phase shift at low frequencies. The relative magnitudes of K_d , K_i and loop proportional gain have to be adjusted to achieve optimum performance without introducing instability.

6.2 PID FILTER COEFFICIENT SCALING FACTORS FOR LM628/629

While the easiest way to determine the PID filter coefficient k_p , k_d , and k_i values is to use tuning as described in Section 2.11, some users may want to use a more theoretical approach to at least find initial starting values before fine tuning. As very often this analysis is performed in the continuous (s) domain and transformed into the discrete digital domain for implementation, the relationship between the continuous domain coefficients and the values input into LM628/629 is of interest.

6.0 Theory (Continued)

6.2.1 PID Filter Difference Equation

In the discrete domain, *Equation (1)* becomes the difference equation:

$$u(n) = K_p e(n) + K_i T \sum_{n=0}^N e(n) + K_d/T_s [e(n) - e(n-1)] \quad (2)$$

Where:

T is the sample interval $2048/f_{CLK}$

T_s is the derivative sample interval $(2048/f_{CLK} \times (1..255))$

6.2.2 Difference Equation with LM628/629 Coefficients

In terms of LM628/629 coefficients, *Equation (2)* becomes:

$$u(n) = k_p e(n) + k_i \sum_{n=0}^N e(n) + k_d [e(n') - e(n' - 0)] \quad (3)$$

Where:

k_p , k_i and k_d are the discrete-time LM628/629 coefficients

$e(n)$ is the position error at sample time n

n' indicates sampling at the derivative sampling rate.

The error signal $e(n)$ [or $e(n')$] is a 16-bit number from the output of the summing junction and is the input to the PID filter. The 15-bit filter coefficients are respectively multiplied by the 16-bit error terms as shown in *Equation (3)A* to produce 32-bit products.

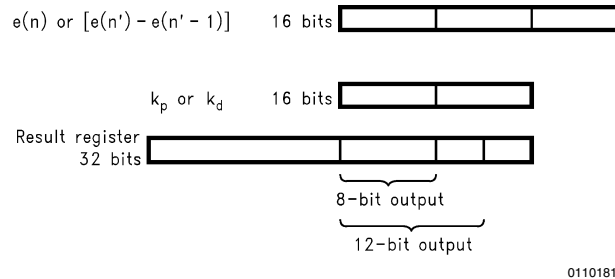

FIGURE 18. Scaling of k_p and k_d

$$\begin{aligned} \text{Result} &= k_p \times e(n)/256 = K_p \times e(n) \therefore k_p \\ &= 256 \times K_p. \end{aligned}$$

Similarly for k_d :

$$\begin{aligned} \text{Result} &= (k_d \times [e(n') - e(n'-1)])/256 \\ &= K_d/T_s \times e(n) \therefore k_d = 256 \times K_d/T_s \end{aligned}$$

Where T_s is the derivative sampling rate.

6.2.5 Scaling for k_i

Figure 19 shows the multiplication and output for the integral term k_i . The use of a 24-bit register for the error terms summation gives further scaling:

$$\begin{aligned} \text{Result} &= k_i/256 \times e(n)/256 \\ &= K_i \times T \therefore k_i = 65536 K_i \times T. \end{aligned}$$

Where T is the sampling interval $2048/f_{CLK}$.

For a 12-bit output the factors are:

6.2.3 LM628/629 PID Filter Output

The proportional coefficient k_p is multiplied by the error signal directly. The error signal is continually summed at the sample rate to previously accumulated errors to form the integral signal and is maintained to 24 bits. To achieve a more usable range from this term, only the most significant 16 bits are used and multiplied by the integral coefficient, k_i . The absolute value of this product is compared with the integration limit, il , and the smallest value, appropriately signed, is used. To form the derivative signal, the previous error is subtracted from the current error over the derivative sampling interval. This is multiplied by the derivative coefficient k_d and the product contributes every sample interval to the output independently of the user chosen derivative sample interval.

The least significant 16 bits of the 32-bit products from the three terms are added together to produce the resulting $u(n)$ of *Equation (3)* each sample interval. From the PID filter 16-bit result, either the most significant 8 or 12 bits are output, depending on the output word size being used. A consequence of this and the use of the 16 MSB's of the integral signal is a scaling of the filter coefficients in relation to the continuous domain coefficients.

6.2.4 Scaling for k_p and k_d

Figure 18 gives details of the multiplication and output for k_p and k_d . Taking the output from the MS byte of the LS 16 bits of the 32-bit result register causes an effective 8-bit right-shift or division of 256 associated with k_p and k_d as follows:

$$k_p = 16 \times K_p, \quad k_d = 16 \times K_d/T_s \quad \text{and} \quad k_i = 4096 K_i \times T.$$

If the 32-bit result register overflows into the most significant 16-bits as a result of a calculation, then all the lower bits are set high to give a predictable saturated output.

6.3 AN EXAMPLE OF A TRAJECTORY CALCULATION

Problem: Determine the trajectory parameters for a motor move of 500 revolutions in 1 minute with 15 seconds of acceleration and deceleration respectively. Assume the optical incremental encoder used has 500 lines.

The LM628/629 quadrature decoder gives four counts for each encoder line giving 2000 counts per revolution in this example. The total number of counts for this position move is $2000 \times 500 = 1,000,000$ counts.

By definition, average velocity during the acceleration and deceleration periods, from and to zero, is half the maximum

6.0 Theory (Continued)

velocity. In this example, half the total time to make the move (30 seconds) is taken by acceleration and deceleration. Thus in terms of time, half the move is made at maximum velocity and half the move at an average velocity of half this maxi-

imum. Therefore, the combined distance traveled during acceleration and deceleration is half that during maximum velocity or $\frac{1}{3}$ of the total, or 333,333 counts. Acceleration and deceleration takes 166,667 counts respectively.

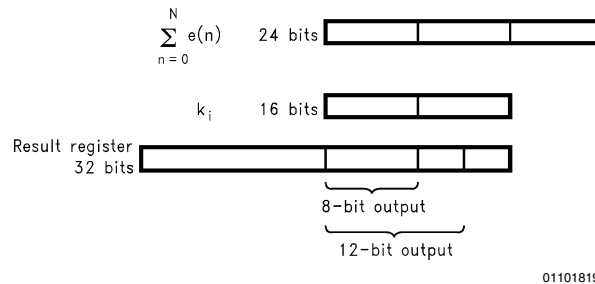

01101819

FIGURE 19. Scaling for k_i

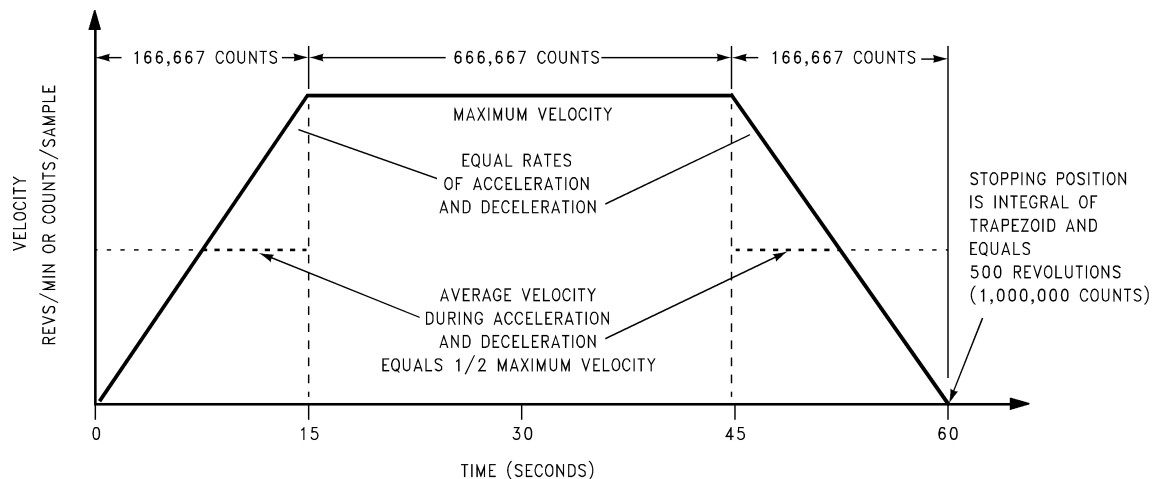

01101820

FIGURE 20. Trajectory Calculation Example Profile

The time interval used by the LM628/629 is the sample interval which is $256 \mu\text{s}$ for a f_{CLK} of 8 MHz.

The number of sample periods in 15 seconds = $15\text{s} / 256 \mu\text{s} = 58,600$ samples

Remembering that distance $s = at^2/2$ is traveled due to acceleration 'a' and time 't'.

$$\begin{aligned} \text{Therefore acceleration } a &= 2S/t^2 \\ &= 2 \times 166,667 / 58,600 \\ &= 97.1 \times 10^{-6} \text{ counts/sample}^2 \end{aligned}$$

Acceleration and velocity values are entered into LM628/629 as a 32-bit integer double-word but represents a 16-bit integer plus 16-bit fractional value. To achieve this acceleration and velocity decimal values are scaled by 65536 and any remaining fractions discarded. This value is then converted to hex to enter into LM628 in four bytes.

$$\begin{aligned} \text{Scaled acceleration } a &= 97.1 \times 10^{-6} \times 65536 \\ &= 6.36 \text{ decimal} = 00000006 \text{ hex.} \end{aligned}$$

The maximum velocity can be calculated in two ways, either by the distance in counts traveled at maximum velocity

divided by the number of samples or by the acceleration multiplied by the number of samples over acceleration duration, as follows:

$$\begin{aligned} \text{Velocity} &= 666,667 / 117,200 = 97.1 \times 10^{-6} \times 58,600 \\ &= 5.69 \text{ counts/sample} \end{aligned}$$

Scaled by 65536 becomes 372,899.8 decimal = 0005B0A3 hex.

Inputting these values for acceleration and velocity with the target position of 1,000,000 decimal, 000F4240 hex will achieve the desired velocity profile.

7.0 Questions and Answers

7.1 THE TWO MOST POPULAR QUESTIONS

Why doesn't the motor move, I've loaded filter parameters, trajectory parameters and issued Update Filter, UDF, and Start, STT, commands?

Answer: The most likely cause is that a stop bit (one of bits 8, 9 or 10 of the trajectory control word) has been set in error,

7.0 Questions and Answers

(Continued)

supposedly to cause a stop in position mode. This is unnecessary, in position mode the trajectory stops automatically at the target position, see Section 3.3.

Can acceleration be changed on the fly?

Answer: No, not directly and a command error interrupt will be generated when STT is issued if acceleration has been changed. Acceleration can be changed if the motor is turned off first using bit 8 of the Load Trajectory Parameter, LTRJ, trajectory control word, see Section 4.6.1.

7.2 MORE ON ACCELERATION CHANGE

What happens at restart if acceleration is changed with the motor drive off and the motor is still moving?

Answer: The trajectory generation starting position is the actual position when the STT command is issued, but assumes that the motor is stationary. If the motor is moving the control loop will attempt to bring the motor back onto an accelerating profile, producing a large error value and less than predictable results. The LM628/629 was not designed with the intention to allow acceleration changes with moving motors.

Is there any way to change acceleration?

Answer: Acceleration change can be simulated by making many small changes of maximum velocity. For instance if a small velocity change is loaded, using LTRJ and STT commands, issuing these repeatedly at predetermined time intervals will cause the maximum velocity to increment producing a piecewise linear acceleration profile. The actual acceleration between velocity increments remains the same.

7.3 MORE ON STOP COMMANDS

What happens if the on-going trajectory is stopped by setting LTRJ control word bits 9 or 10, stop abruptly or stop smoothly, and then restarted by issuing Start, STT?

Answer: While stopped the motor position will be held by the control loop at the position determined as a result of issuing the stop command. Issuing STT will cause the motor to restart the trajectory toward the original target position with normal controlled acceleration.

What happens if the on-going trajectory is stopped by setting LTRJ control word bit 8, motor-off?

Answer: The LM628's DAC output is set to mid-scale, this puts zero volts on the motor which will still have a dynamic braking effect due to the commutation diodes. The LM629's PWM output sets the magnitude output to zero with a similar effect. If the motor freewheels or is moved the desired and actual positions will be the same. This can be verified using the RDDP and RDRP commands. When Start, STT, is issued the loop will be closed again and the motor will move toward the original trajectory from the actual current position.

If the motor is off, how can the control loop be closed and the motor energized?

Answer: Simply by issuing the Start, STT command. If any previous trajectory has completed then the motor will be held in the current position. If a trajectory was in progress when the motor-off command was issued then the motor will restart and move to the target position in position mode, or resume movement in velocity mode.

7.4 MORE ON DEFINE HOME

What happens if the Define Home command, DFH, is issued while a current trajectory is in progress?

Answer: The position where the DFH command is issued is reset to zero, but the motor still stops at the original position commanded, i.e., the position where DFH is issued is subtracted from the original target position.

Does issuing Define Home, DFH, zero both the trajectory and position register?

Answer: Yes, use Read Real Position, RDRP, and Read Desired Position, RDDP to verify.

7.5 MORE ON VELOCITY

Why is a command error interrupt generated when inputting negative values of relative velocity?

Answer: Because the negative relative velocity would cause a negative absolute velocity which is not allowed. Negative absolute values of velocity imply movement in the negative direction which can be achieved by inputting a negative position value or in velocity mode by not setting bit 12. Similarly negative values of acceleration imply deceleration which occurs automatically at the acceleration rate when the LM628/629 stops the motor in position mode or if making a transition from a higher to a lower value of velocity.

What happens in velocity (or position) mode when the position range is exceeded?

Answer: The position range extends from maximum negative position hex'C0000000' to maximum positive position hex'3FFFFFFF' using a 32-bit double word. Bit 31 is the direction bit, logic 0 indicates forward direction, bit 30 is the wraparound bit used to control position over-range in velocity (or position) mode.

When the position increases past hex'3FFFFFFF' the wraparound bit 30 is set, which also sets the wraparound bit in the Status byte bit 4. This can be polled by the host or optionally used to interrupt the host as defined by the MSKI commands. Essentially the host has to manage wraparound by noting its occurrence and resetting the Status byte wraparound bit using the RSTI command. When the wraparound bit 30 is set in the position register so is the direction bit. This means one count past maximum positive position hex'3FFFFFFF' moves the position register onto the maximum negative position hex'C0000000'. Continued increase in positive direction causes the position register to count up to zero and back to positive values of position and on toward another wraparound.

Similarly when traveling in a negative direction, using two's complement arithmetic, position counts range from hex'FFFFFFF' (-1 decimal) to the maximum negative position of hex'C0000000'. One more negative count causes the position register to change to hex'3FFFFFFF', the maximum positive position. This time the wraparound bit 30 is reset, causing the wraparound bit 4 of the status byte to be set. Also the direction bit 31 is reset to zero. Further counts in the negative direction cause the position register to count down to zero as would be expected. With management there is no reason why absolute position should be lost, even when changing between velocity and position modes.

7.0 Questions and Answers

(Continued)

7.6 MORE ON USE OF COMMANDS

If filter parameter and trajectory commands are pipelined for synchronization of axes, can the Update Filter, UDF, and Start, STT, commands be issued consecutively?

Answer: Yes.

Can commands be issued between another command and its data?

Answer: No.

What is the response time of the set breakpoint commands, SBPA and SBPR?

Answer: There is an uncertainty of one sample interval in the setting of the breakpoint bit 6 in the Status Byte in response to these commands.

What happens when the Set Index Position, SIP, command is issued?

Answer: On the next occurrence of all three inputs from the position encoder being low the corresponding position is loaded into the index register. This can be read with the Read Index Position command, RDIP. Bit 0 of the Read Signals register, shows when an SIP command has been issued but the index position has not yet been acquired. RDSIGS command accesses the Read Signals Register.

What happens if the motor is not able to keep up with the specified trajectory acceleration and velocity values?

Answer: A large, saturated, position error will be generated, and the control loop will be non-linear. The acceleration and velocity values should be set within the capability of the motor. Read Desired and Real Position commands, RDDP and RDRP can be used to determine the size of the error. The Load Position Error commands, for either host Interrupt or motor Stopping, LPEI and LPES, can be used to monitor the error size for controlled action where safety is a factor.

When is the command error bit 1 in the Status Byte set?

Answer:

1. When an acceleration change is attempted when the motor is moving and the drive on.
2. When loading a relative velocity would cause a negative absolute velocity.
3. Incorrect reading and writing operations generally.

What does the trajectory complete bit 2 in the Status Byte indicate?

Answer: That the trajectory loaded by LTRJ and initiated by STT has completed. The motor may or may not be at this position. Bit 2 is also set when the motor stop commands are executed and completed.

What do the specified minimum and maximum values of velocity mean in reality?

Answer: Assume a 500 line encoder = 1/2000 revs/count is used.

The maximum LM628/629 velocity is 16383 counts/sample and for a 8 MHz clock the LM628/629 sample rate is 3.9k samples/second, multiplying these values gives 32k revs/second or 1.92M rpm.

The maximum encoder rate is 1M counts/second multiplied by 1/2000 revs/count gives 500 revs/second or 30k rpm. The encoder capture rate therefore sets the maximum velocity limit.

The minimum LM628/629 velocity is 1/65536 counts/sample (one fractional count), multiplying this value by the sample rate and encoder revs/count gives 30×10^{-6} revs/second or 1.8×10^{-3} rpm.

The LM628 provides no limitation to practical values of velocity.

How long will it take to get to position wraparound in velocity mode traveling at 5000 rpm with a 500 line encoder?

Answer: 107 minutes.

8.0 References and Further Reading

1. LM628/LM629 Precision Motion Controller. Data sheet March 1989.
2. Automatic Control Systems. Benjamin C. Kuo. Fifth edition Prentice-Hall 1987.
3. DC Motors, Speed Controls, Servo Systems. Robbins & Myers/Electro Craft.
4. PID Algorithms and their Computer Implementation. D.W. Clarke. Institute of Measurement and Control, Trans. v. 6 No. 6 Oct/Dec 1984 86/178.
5. LM628 Programming Guide. Steven Hunt. National Semiconductor Application Note AN-693.

Notes

LIFE SUPPORT POLICY

NATIONAL'S PRODUCTS ARE NOT AUTHORIZED FOR USE AS CRITICAL COMPONENTS IN LIFE SUPPORT DEVICES OR SYSTEMS WITHOUT THE EXPRESS WRITTEN APPROVAL OF THE PRESIDENT AND GENERAL COUNSEL OF NATIONAL SEMICONDUCTOR CORPORATION. As used herein:

1. Life support devices or systems are devices or systems which, (a) are intended for surgical implant into the body, or (b) support or sustain life, and whose failure to perform when properly used in accordance with instructions for use provided in the labeling, can be reasonably expected to result in a significant injury to the user.
2. A critical component is any component of a life support device or system whose failure to perform can be reasonably expected to cause the failure of the life support device or system, or to affect its safety or effectiveness.



National Semiconductor Corporation
Americas
Email: support@nsc.com

www.national.com

National Semiconductor Europe

Fax: +49 (0) 180-530 85 86
Email: europe.support@nsc.com
Deutsch Tel: +49 (0) 69 9508 6208
English Tel: +44 (0) 870 24 0 2171
Français Tel: +33 (0) 1 41 91 8790

National Semiconductor Asia Pacific Customer Response Group

Tel: 65-2544466
Fax: 65-2504466
Email: ap.support@nsc.com

National Semiconductor Japan Ltd.

Tel: 81-3-5639-7560
Fax: 81-3-5639-7507