

### I2C Real time clock

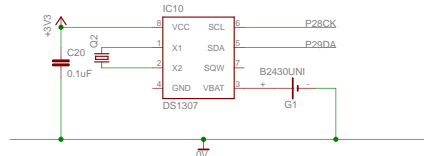

### Analog 0-3.3V inputs

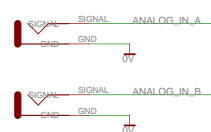

### Serial Q12-13 and Q22-23

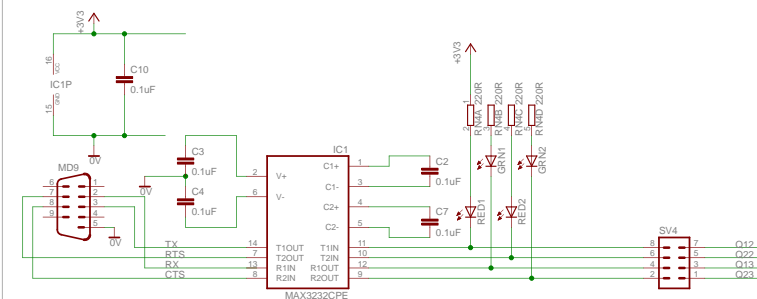

### I2C 16 inputs/outputs

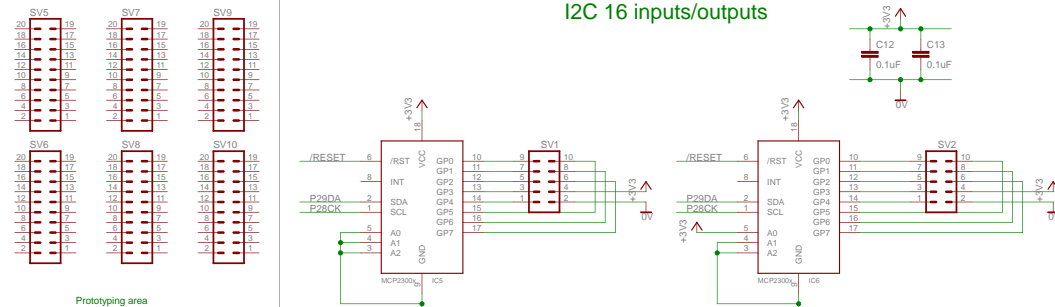

### Analog Input Q13 and SPI bus

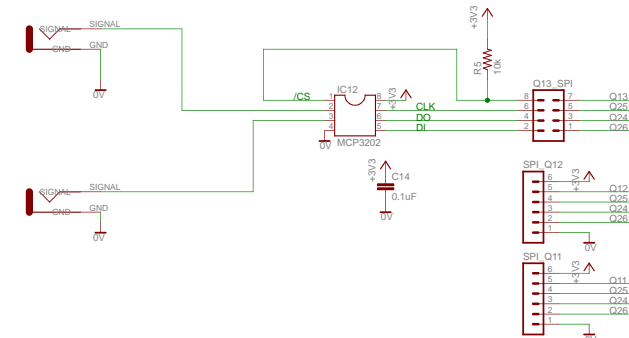

### SD card Q24-27

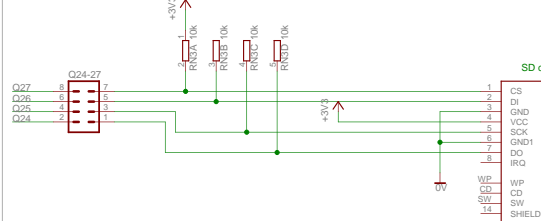

### As well as reset transistor and associated components

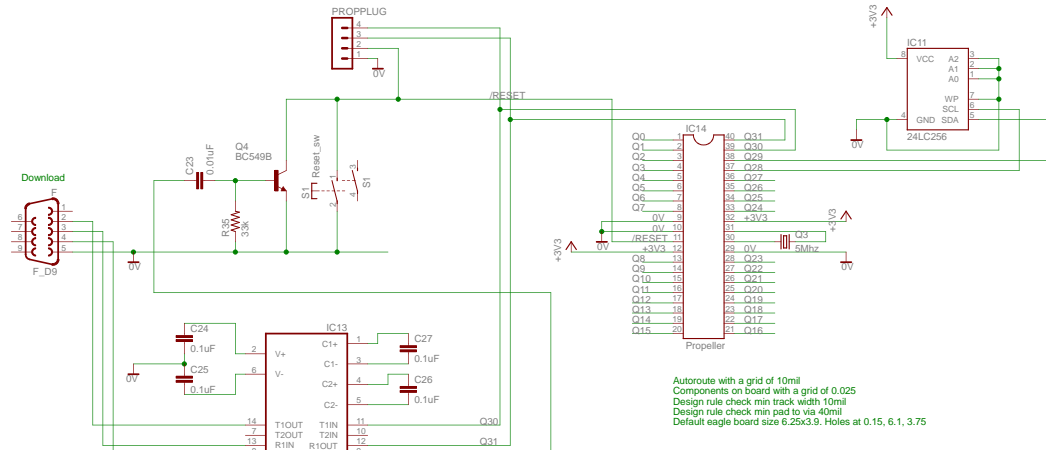

### MIDI Group Q18-19

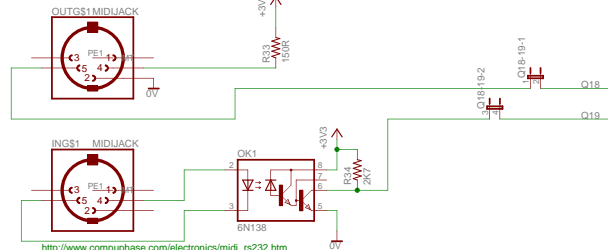

### VGA/TV Q16-23

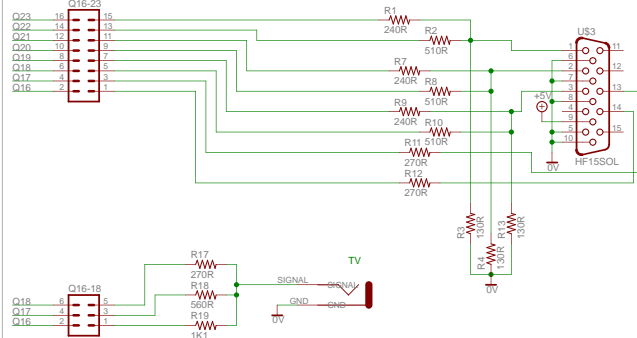

### RF transceiver Q9-10

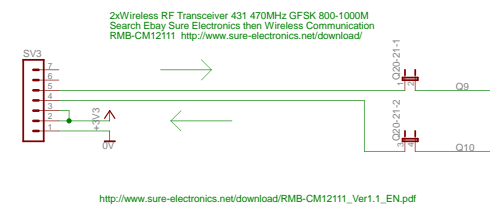

### Data comms

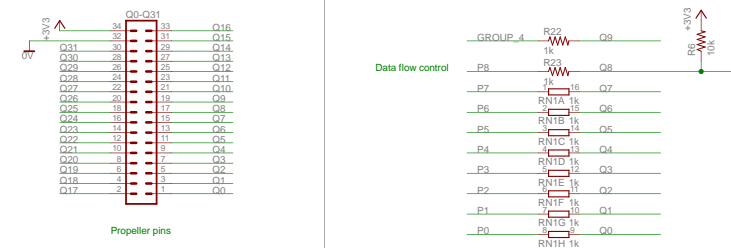

### Keyboard Q14-15

