

# SPECIFICATION FOR TFT LCD MODULE

<b>MODEL NO:</b>	<b>TM240320C1NFWGWC</b>
<b>CUSTOMER:</b>	
<b>CUSTOMER P/N.</b>	
<b>VERSION</b>	<b>V1.0</b>
<b>CUSTOMER APPROVED</b>	

**Preliminary Specification**

**Final Specification**

PREPARED	CHECKED	VERIFIED BY QC DEPT	VERIFIED BY R&D DEPT

-----  
 TIANMA MICRO-ELECTRONICS CO., LTD

Address: 22/F Hangdu Building, Catic Zone, Shen Nan Road Central, ShenZhen, China

Tel: +86-755-8379-0744

Fax: +86-755-8379-0431

Web: [www.tianma.cn](http://www.tianma.cn) [www.tianma.com](http://www.tianma.com)

-----

**REVISION RECORD**

Date	Rev.No.	Page	Revision Items	Prepared
2008.03.14	V1.0		The first release	陈泽锴

# CONTENTS

	<b>Page</b>
1. General Specifications -----	<b>1</b>
2. Outline Drawing -----	<b>2</b>
3. Circuit Block Diagram -----	<b>3</b>
4. Absolute Maximum Ratings -----	<b>4</b>
5. Electrical Specifications and Instruction Code -----	<b>5</b>
6. Optical Characteristics -----	<b>10</b>
7. Reliability Test Items and Criteria -----	<b>14</b>
8. Quality level-----	<b>15</b>
9. Precautions for Use of LCD Modules -----	<b>20</b>

## 1. General Specifications

TM240320C1NFWGWC is a color active matrix LCD module incorporating **amorphous silicon** TFT (Thin Film Transistor). It is composed of a color TFT-LCD panel, driver IC, FPC and a back light unit. The **2.4"** display area contains **240 x 320** pixels and can display up to **65K** colors. This product accords with RoHS environmental criterion.

Item	Contents	Unit	Note
LCD Type	TFT	-	
Display Color	65K		1
LCD Duty	1/320	-	
Viewing Direction	6:00	O'Clock	
Active Area(W×H)	36.72×48.96	mm	
Number of Dots	240(RGB)×320	mm	
Dot Pitch(W×H)	0.153X0.153	mm	
Controller	ILI9325		
V <sub>DD</sub>	2.8V	V	
V <sub>DDIO</sub>	1.8V	V	
Outline Dimensions	Refer to outline drawing on next page		
Backlight	3-LEDs(white)	-	
Weight	TBD	g	
Interface	8080-8/16bit	-	
Polarizer Mode	Transmissive/Positive	-	

Note 1: Color tune is slightly changed by temperature and driving voltage.

## 2. Outline Drawing

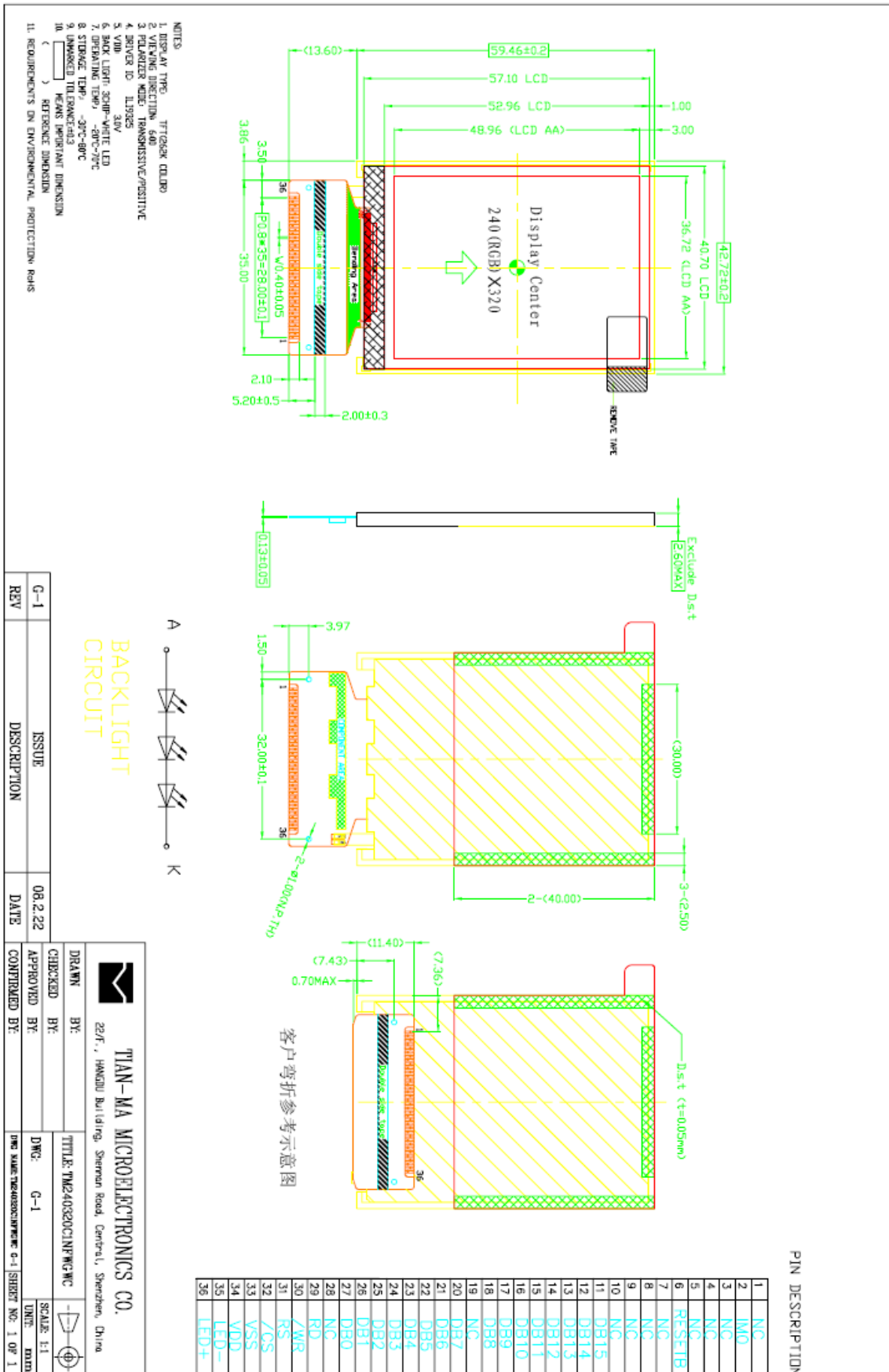



#### 4. Absolute Maximum Ratings(Ta=25°C)

Item	Symbol	Min.	Max.	Unit	Note
Power Supply Voltage	V <sub>DD</sub>	-0.3	3.3	V	1, 2
Logic Signal Input /Output Voltage	V <sub>I/OVCC</sub>	-0.3	V <sub>DD</sub> +0.3	V	
Operating Temperature	Top	-20	+70	°C	
Storage Temperature	Tst	-30	+80	°C	

##### Notes:

1. If the module is above these absolute maximum ratings. It may become permanently damaged.  
Using the module within the following electrical characteristic conditions are also exceeded, the module will malfunction and cause poor reliability.
2. V<sub>DD</sub> > V<sub>SS</sub> must be maintained.

## 5. Electrical Specifications and Instruction Code

### 5.1 Electrical characteristics( $V_{SS}=0V$ , $T_a=25^{\circ}C$ )

Parameter	Symbol	Condition	Min	Typ	Max	Unit	Note	
Input voltage	'H'	$V_{IH}$	$V_{DD}=2.8V$	$0.8V_{DD}$	-	$V_{DD}$	V	
	'L'	$V_{IL}$	$V_{DD}=2.8V$	$V_{SS}$	-	$0.2V_{DD}$	V	
Output Voltage	'H'	$V_{OH}$	-	$0.8V_{DD}$	-	$V_{DD}$	V	
	'L'	$V_{OL}$	-	$V_{SS}$	-	$0.2V_{DD}$	V	
Current Consumption	$I_{CC1}$	Normal mode	-	25	-	mA	1,3	
	$I_{CC2}$	Standby mode	-	-	-	mA	2	

Note:

1: Display full white. Backlight on state.

2: IC on standby mode.

3: the default voltage is 3.3V, for 3 lights in series, the power is that the current multiply 3.



**5.2 LED backlight specification(V<sub>ss</sub>=0V ,T<sub>a</sub>=25°C)**

Item		Symbol	Condition	Min	Typ	Max	Unit	Note
Supply voltage		-	-	2.5	2.8	3.3	V	
Supply current		I <sub>f</sub>	V <sub>f</sub> =9.6V	-	20		mA	
Reverse voltage		V <sub>r</sub>	-	-	-	-	V	
Forward current	Normal	I <sub>pn</sub>	3-chip Serial		20	-	mA	
	Dimming	I <sub>pd</sub>						
Reverse Current		I <sub>r</sub>	-	-	-	-	μA	
Uniformity		ΔBp		80%				
Color coordinate*		X	I <sub>f</sub> =20mA	0.26	-	0.31	-	
		Y		0.26	-	0.31	-	

### 5.3 Interface Signals

Pin No.	Symbol	I/O	Function
1	NC	-	No connect
2	IM0	I	8/16 bit select pin,IM0=L,16bit;IM0=H,8bit
3	NC	-	No connect
4	NC	-	No connect
5	NC	-	No connect
6	RESET	I	RESET PIN
7	NC	-	No connect
8	NC	-	No connect
9	NC	-	No connect
10	NC	-	No connect
11	DB15	I/O	DATA 15
12	DB14	I/O	DATA 14
13	DB13	I/O	DATA 13
14	DB12	I/O	DATA 12
15	DB11	I/O	DATA 11
16	DB10	I/O	DATA 10
17	DB9	I/O	DATA 9
18	DB8	I/O	DATA 8
19	NC	-	No connect
20	DB7	I/O	DATA 7
21	DB6	I/O	DATA 6
22	DB5	I/O	DATA 5
23	DB4	I/O	DATA 4
24	DB3	I/O	DATA 3
25	DB2	I/O	DATA 2
26	DB1	I/O	DATA 1
27	DB0	I/O	DATA 0
28	NC	-	No connect
29	RD	I	Read pin
30	/WR	I	Write pin
31	RS	I	DATA/COMMAND select pin
32	/CS	I	LCD chip select pin
33	VSS	P	Ground
34	VDD	P	Power supply

### 5.3 Interface Signals(continued)

Pin No.	Symbol	I/O	Function
35	LED-	I	LCD backlight -
36	LED+	I	LCD backlight +
37			
38			
39			
40			
41			
42			
43			
44			
45			
46			
47			
48			
49			
50			
51			
52			
53			
54			
55			
56			
57			
58			
59			
60			

### 5.4 Interface Timing Chart

Note: Please refer to ILITEK's [\\_ILI9325](#) data sheet for more details.

ILITEK's [\\_ILI9325](#) INTERFACE PROTOCOL

Inter 8080 system CPU interface

#### *i80 18-/16-bit System Bus Interface Timing*

##### (a) Write to register

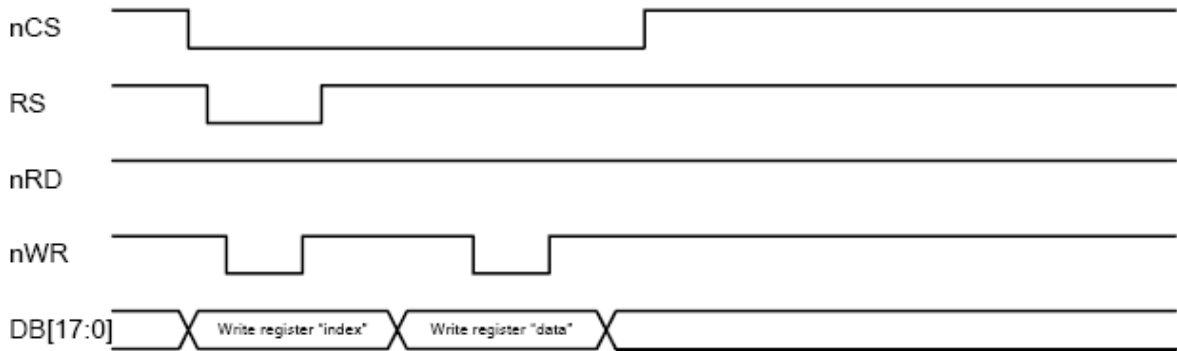

### INSTRUCTION DESCRIPTION(ILITEK's [\\_ILI9325](#))



a-Si TFT LCD Single Chip Driver  
240RGBx320 Resolution and 262K color

**ILI9325**

#### 8.2. Instruction Descriptions

No.	Registers Name	RW	RS	D15	D14	D13	D12	D11	D10	D9	D8	D7	D6	D5	D4	D3	D2	D1	D0		
00h	Driver Code Read	R	1	1	0	0	1	0	0	1	1	0	0	1	0	0	1	0	1		
01h	Driver Output Control 1	W	1	0	0	0	0	0	SM	0	SS	0	0	0	0	0	0	0	0		
02h	LCD Driving Control	W	1	0	0	0	0	0	0	BC0	EOR	0	0	0	0	0	0	0	0		
03h	Entry Mode	W	1	TRI	DFM	0	BGR	0	0	HWM	0	ORG	0	ID1	I/D0	AM	0	0	0		
04h	Resize Control	W	1	0	0	0	0	0	0	RCV1	RCV0	0	0	RCH1	RCH0	0	0	RSZ1	RSZ0		
07h	Display Control 1	W	1	0	0	PTDE1	PTDE0	0	0	0	BASEE	0	0	GON	DTE	CL	0	D1	D0		
08h	Display Control 2	W	1	0	0	0	0	FP3	FP2	FP1	FP0	0	0	0	0	BP3	BP2	BP1	BP0		
09h	Display Control 3	W	1	0	0	0	0	0	0	PTS2	PTS1	PTS0	0	0	PTG1	PTG0	ISC3	ISC2	ISC1	ISC0	
0Ah	Display Control 4	W	1	0	0	0	0	0	0	0	0	0	0	0	0	FMARKOE	FMI2	FMI1	FMI0		
0Ch	RGB Display Interface Control 1	W	1	0	ENC2	ENC1	ENC0	0	0	0	RM	0	0	DM1	DM0	0	0	RIM1	RIM0		
0Dh	Frame Maker Position	W	1	0	0	0	0	0	0	0	0	FMP6	FMP7	FMP6	FMP5	FMP4	FMP3	FMP2	FMP1	FMP0	
0Fh	RGB Display Interface Control 2	W	1	0	0	0	0	0	0	0	0	0	0	VSPL	HSPL	0	0	DPL	EPL		
10h	Power Control 1	W	1	0	0	0	SAP	0	BT2	BT1	BT0	APE	AP2	AP1	AP0	0	DSTB	SLP	STB		
11h	Power Control 2	W	1	0	0	0	0	0	DC12	DC11	DC10	0	DC02	DC01	DC00	0	VC2	VC1	VC0		
12h	Power Control 3	W	1	0	0	0	0	0	0	0	0	0	VCIRE	0	0	PON	VRH3	VRH2	VRH1	VRH0	
13h	Power Control 4	W	1	0	0	0	VDV4	VDV3	VDV2	VDV1	VDV0	0	0	0	0	0	0	0	0		
20h	Horizontal GRAM Address Set	W	1	0	0	0	0	0	0	0	0	AD7	AD6	AD5	AD4	AD3	AD2	AD1	AD0		
21h	Vertical GRAM Address Set	W	1	0	0	0	0	0	0	0	0	AD16	AD15	AD14	AD13	AD12	AD11	AD10	AD9	AD8	
22h	Write Data to GRAM	W	1	RAM write data (WD17-0) / read data (RD17-0) bits are transferred via different data bus lines according to the selected interfaces.																	
28h	Power Control 7	W	1	0	0	0	0	0	0	0	0	0	0	0	0	0	0	0	0		
2Bh	Frame Rate and Color Control	W	1	0	0	0	0	0	0	0	0	0	0	0	0	0	0	0	0		
30h	Gamma Control 1	W	1	0	0	0	0	0	0	KP1[2]	KP1[1]	KP1[0]	0	0	0	0	0	KP0[2]	KP0[1]	KP0[0]	
31h	Gamma Control 2	W	1	0	0	0	0	0	0	KP3[2]	KP3[1]	KP3[0]	0	0	0	0	0	KP2[2]	KP2[1]	KP2[0]	
32h	Gamma Control 3	W	1	0	0	0	0	0	0	KP5[2]	KP5[1]	KP5[0]	0	0	0	0	0	KP4[2]	KP4[1]	KP4[0]	
35h	Gamma Control 4	W	1	0	0	0	0	0	0	RP1[2]	RP1[1]	RP1[0]	0	0	0	0	0	RP0[2]	RP0[1]	RP0[0]	
36h	Gamma Control 5	W	1	0	0	0	VRP1[4]	VRP1[3]	VRP1[2]	VRP1[1]	VRP1[0]	0	0	0	0	0	0	VRP0[3]	VRP0[2]	VRP0[1]	VRP0[0]
37h	Gamma Control 6	W	1	0	0	0	0	0	0	KN1[2]	KN1[1]	KN1[0]	0	0	0	0	0	KN0[2]	KN0[1]	KN0[0]	
38h	Gamma Control 7	W	1	0	0	0	0	0	0	KN3[2]	KN3[1]	KN3[0]	0	0	0	0	0	KN2[2]	KN2[1]	KN2[0]	
39h	Gamma Control 8	W	1	0	0	0	0	0	0	KN5[2]	KN5[1]	KN5[0]	0	0	0	0	0	KN4[2]	KN4[1]	KN4[0]	
3Ch	Gamma Control 9	W	1	0	0	0	0	0	0	RN1[2]	RN1[1]	RN1[0]	0	0	0	0	0	RN0[2]	RN0[1]	RN0[0]	
3Dh	Gamma Control 10	W	1	0	0	0	VRN1[4]	VRN1[3]	VRN1[2]	VRN1[1]	VRN1[0]	0	0	0	0	0	0	VRN0[3]	VRN0[2]	VRN0[1]	VRN0[0]
50h	Horizontal Address Start	W	1	0	0	0	0	0	0	0	0	0	HSA7	HSA6	HSA5	HSA4	HSA3	HSA2	HSA1	HSA0	

The information contained herein is the exclusive property of ILI Technology Corp. and shall not be distributed, reproduced, or disclosed in whole or in part without prior written permission of ILI Technology Corp.

No.	Registers Name	R/W	RS	D15	D14	D13	D12	D11	D10	D9	D8	D7	D6	D5	D4	D3	D2	D1	D0
	Position																		
51h	Horizontal Address End Position	W	1	0	0	0	0	0	0	0	0	HEA7	HEA6	HEA5	HEA4	HEA3	HEA2	HEA1	HEA0
52h	Vertical Address Start Position	W	1	0	0	0	0	0	0	0	VSA8	VSA7	VSA6	VSA5	VSA4	VSA3	VSA2	VSA1	VSA0
53h	Vertical Address End Position	W	1	0	0	0	0	0	0	0	VEA8	VEA7	VEA6	VEA5	VEA4	VEA3	VEA2	VEA1	VEA0
60h	Driver Output Control 2	W	1	GS	0	NL5	NL4	NL3	NL2	NL1	NL0	0	0	SCN5	SCN4	SCN3	SCN2	SCN1	SCN0
61h	Base Image Display Control	W	1	0	0	0	0	0	0	0	0	0	0	0	0	0	NDL	VLE	REV
6Ah	Vertical Scroll Control	W	1	0	0	0	0	0	0	0	0	VL8	VL7	VL6	VL5	VL4	VL3	VL2	VL1
80h	Partial Image 1 Display Position	W	1	0	0	0	0	0	0	0	0	PTDP08	PTDP07	PTDP06	PTDP05	PTDP04	PTDP03	PTDP02	PTDP01
81h	Partial Image 1 Area (Start Line)	W	1	0	0	0	0	0	0	0	0	PTSA08	PTSA07	PTSA06	PTSA05	PTSA04	PTSA03	PTSA02	PTSA01
82h	Partial Image 1 Area (End Line)	W	1	0	0	0	0	0	0	0	0	PTEA08	PTEA07	PTEA06	PTEA05	PTEA04	PTEA03	PTEA02	PTEA01
83h	Partial Image 2 Display Position	W	1	0	0	0	0	0	0	0	0	PTDP18	PTDP17	PTDP16	PTDP15	PTDP14	PTDP13	PTDP12	PTDP11
84h	Partial Image 2 Area (Start Line)	W	1	0	0	0	0	0	0	0	0	PTSA18	PTSA17	PTSA16	PTSA15	PTSA14	PTSA13	PTSA12	PTSA11
85h	Partial Image 2 Area (End Line)	W	1	0	0	0	0	0	0	0	0	PTEA18	PTEA17	PTEA16	PTEA15	PTEA14	PTEA13	PTEA12	PTEA11
90h	Panel Interface Control 1	W	1	0	0	0	0	0	0	DIV11	DIV10	0	0	0	0	RTN13	RTN12	RTN11	RTN10
92h	Panel Interface Control 2	W	1	0	0	0	0	0	NOV12	NOW11	NOW10	0	0	0	0	0	0	0	0
95h	Panel Interface Control 4	W	1	0	0	0	0	0	0	DIVE1	DIVE0	0	0	RTNE5	RTNE4	RTNE3	RTNE2	RTNE1	RTNE0
A1h	OTP VCM Programming Control	W	1	0	0	0	0	OTP_PGM_EN	0	0	0	0	0	VCM_OTP5	VCM_OTP4	VCM_OTP3	VCM_OTP2	VCM_OTP1	VCM_OTP0
A2h	OTP VCM Status and Enable	W	1	PGM_CNT1	PGM_CNT0	VCM_D5	VCM_D4	VCM_D3	VCM_D2	VCM_D1	VCM_D0	0	0	0	0	0	0	0	VCM_EN
A5h	OTP Programming ID Key	W	1	KEY_15	KEY_14	KEY_13	KEY_12	KEY_11	KEY_10	KEY_9	KEY_8	KEY_7	KEY_6	KEY_5	KEY_4	KEY_3	KEY_2	KEY_1	KEY_0

## 6. Optical Characteristics

Item	Symbol	Condition	Min.	Typ.	Max.	Unit	Note
Brightness	Bp	$\theta=0^\circ$	2900	-	-	Cd/m <sup>2</sup>	1
Uniformity	$\Delta Bp$	$\Phi=0^\circ$	80%	-	-		1,2
Viewing Angle	$\theta_1$ ( $\Phi=90^\circ$ or $270^\circ$ )	$Cr \geq 10$	-20~+40			Deg	3
	$\theta_2$ ( $\Phi=0^\circ$ or 180°)						
Contrast Ratio	Cr	$\theta=0^\circ$ $\Phi=0^\circ$		350		-	4
Response Time	$t_{on}$		-	25	40	ms	5
	$t_{off}$	-	25	40	ms		
Color of CIE Coordinate	W	x	-	TBD	-	-	1,6
		y	-	TBD	-	-	
	R	x	-	TBD	-	-	
		y	-	TBD	-	-	
	G	x	-	TBD	-	-	
		y	-	TBD	-	-	
B	x	-	TBD	-	-		
	y	-	TBD	-	-		
NTSC Ratio	S		TBD	TBD			

Note: The parameter is slightly changed by temperature, driving voltage and materiel.

Note 1: The data are measured after LEDs are turned on for 5 minutes. LCM displays full white. The brightness is the average value of 9 measured spots. Measurement equipment PR-705 (Φ8mm)

Measuring condition:

- Measuring surroundings: Dark room.
- Measuring temperature: Ta=25°C.
- Adjust operating voltage to get optimum contrast at the center of the display.

Measured value at the center point of LCD panel after more than 5 minutes while backlight turning on.

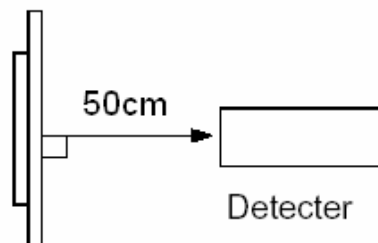

Note 2: The luminance uniformity is calculated by using following formula.

$$\Delta Bp = Bp (\text{Min.}) / Bp (\text{Max.}) \times 100 (\%)$$

Bp (Max.) = Maximum brightness in 9 measured spots

Bp (Min.) = Minimum brightness in 9 measured spots.

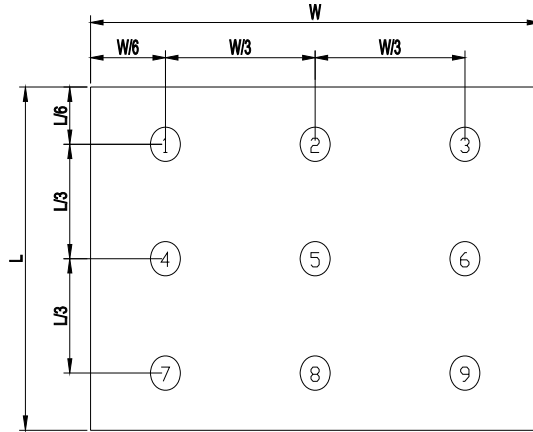

Measurement equipment PR-705 (Φ8mm)

Note 3: The definition of viewing angle:

Refer to the graph below marked by  $\theta$  and  $\phi$

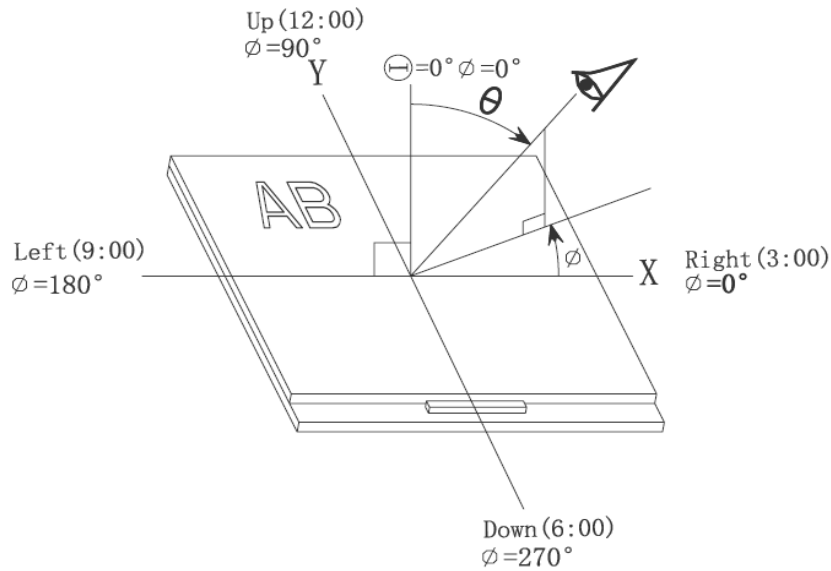

Note 4: The definition of contrast ratio (Test LCM using PR-705):

$$\text{Contrast Ratio(CR)} = \frac{\text{Luminance When LCD is at "White" state}}{\text{Luminance When LCD is at "Black" state}}$$

(Contrast Ratio is measured in optimum common electrode voltage)

Note 5: Definition of Response time. (Test LCD using DMS501):

The output signals of photo detector are measured when the input signals are changed

from “black” to “white”(falling time) and from “white” to “black”(rising time), respectively. The response time is defined as the time interval between the 10% and 90% of amplitudes.Refer to figure as below.

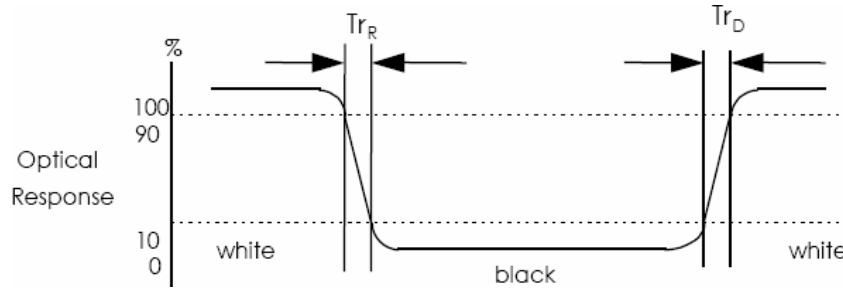

The definition of response time

Note 6: Definition of Color of CIE Coordinate and NTSC Ratio.

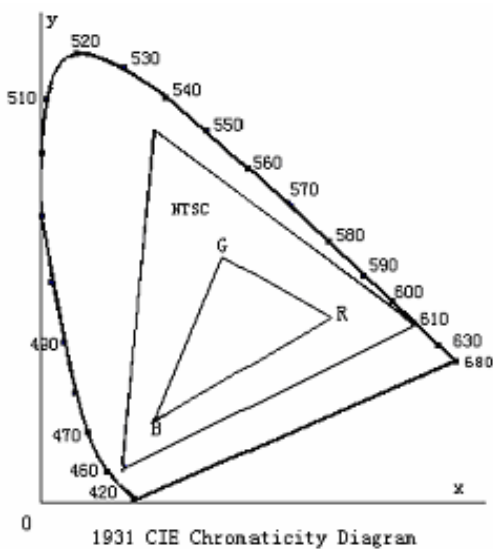

Color gamut:

$$S = \frac{\text{area of RGB triangle}}{\text{area of NTSC triangle}} \times 100\%$$



## 7. Reliability Test Items and Criteria

No	Test Item	Test condition	Criterion
1	High Temperature Storage	80°C±2°C 96H Restore 2H at 25°C Power off	1. After testing, cosmetic and electrical defects should not happen. 2.Total current consumption should not be more than twice of initial value.
2	Low Temperature Storage	-30°C±2°C 96H Restore 2H at 25°C Power off	
3	High Temperature Operation	70°C±2°C 96H Restore 2H at 25°C Power on	
4	Low Temperature Operation	-20°C±2°C 96H Restore 4H at 25°C Power on	
5	High Temperature/Humidity Operation	60°C±2°C 90%RH 96H Power on	
6	Temperature Cycle	-30°C→25°C→80°C 30min 5min 30min after 10cycle, Restore 2H at 25°C Power off	
7	Vibration Test	10Hz~150Hz, 100m/s <sup>2</sup> , 120min	Not allowed cosmetic and electrical defects.
8	Shock Test	Half- sine wave,300m/s <sup>2</sup> ,11ms	
9	Drop Test(package state)	800mm, concrete floor,1corner, 3edges, 6 sides each time	1.After testing, cosmetic and electrical defects should not happen. 2.the product should remain at initial place 3.Product uncovered or package broken is not permitted.

Note:Additional test Item proposed by customer shall be determined by mutual agreement between customer and Tianma

## 8 Quality level

### 8.1 Classification of defects

Major defects (MA): A major defect refers to a defect that may substantially degrade usability for product applications. All functional defects: no display、display abnormally、open or missing segment、short circuit, missing component, outline dimension beyond the drawing, and progressive defects and those affecting reliability.

Minor defects (MI): A minor defect refers to a defect which is not considered to be able substantially degrade the product application or a defect that deviates from existing standards almost unrelated to the effective use of the product or its operation. Black spot, White spot, Bright spot, Pinhole, Black line, White line, Contrast variation, Bubble(Bubble in the cell is not included),Glass defect, and Polarizer defect beyond the standard as follows.

### 8.2 Definition of inspection range

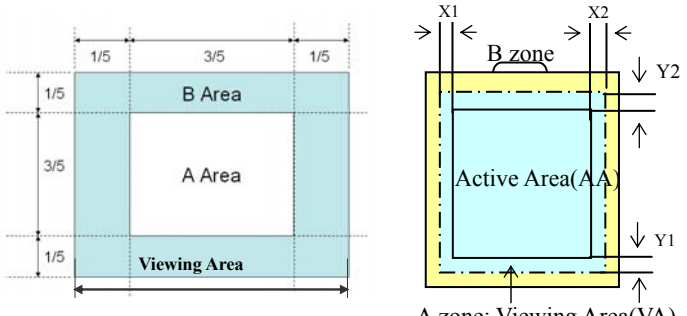
<p>For dot defect of TFT LCD which is not smaller than 3 inches, dividing three areas to make a judgment (according to figure 1).</p> <p>A area : center of viewing area          B area : periphery of viewing area          C area : Outside viewing area</p> <p>For other defects, dividing two areas to make a judgment (according figure 2).</p> <p>A zone : Inside Viewing area          B zone : Outside Viewing area</p> <p>X1(A.A~V.A): -mm    X2(A.A~V.A): -mm          Y1(A.A~V.A): -mm    Y2(A.A~V.A): -mm</p>	
	<p>Figure 1</p> <p>Figure 2</p>

### 8.3 Inspection items and general notes

General notes	<p>①Should any defects which are not specified in this standard happen, additional standard shall be determined by mutual agreement between customer and TIANMA.</p> <p>②Viewing area should be the area which TIANMA guarantees.</p> <p>③Limited sample should be prior to this Inspection standard.</p> <p>④Viewing judgment should be under static pattern.</p> <p>⑤Inspection conditions          Inspection distance: 250 mm (from the sample)    Temperature : 25±5 °C          Inspection angle : 45 degrees in 6 o'clock direction (all defects in viewing area should be inspected from this direction)</p>	
Inspection items	Pinhole, Bright spot, Black spot, White spot, Black line, White Line, Foreign particle, Bubble	The color of a small area is different from the remainder. The phenomenon doesn't change with voltage
	Contrast variation	The color of a small area is different from the remainder. The phenomenon changes with voltage
	Polarizer defect	Scratch, Dirt, Particle, Bubble on polarizer or between polarizer and glass
	Dot defect (TFT LCD)	the pixel appears bright or dark abnormally when display.

Functional defect	no display, display abnormally, open or missing segment, short circuit, False viewing direction
Glass defect	Glass crack, Shaved corner of glass, Surplus glass
Segment defect	Pin holes or cracks in segment, Transformation of segment
PCB defect	Components assembly defect

#### 8.4 Outgoing Inspection level

Outgoing Inspection standard	Inspection conditions	Inspection				
		Min.	Max.	Unit	IL	AQL
Major Defects	See 8.3 general notes	See 8.5			II	0.65
Minor Defects	See 8.3 general notes	See 8.5			II	1.5

Note: Sampling standard conforms to GB2828

#### 8.5 Inspection Items and Criteria

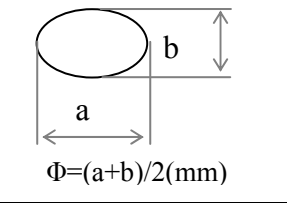
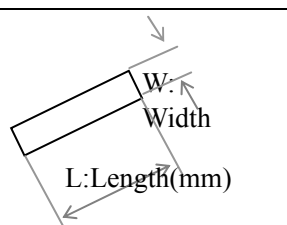
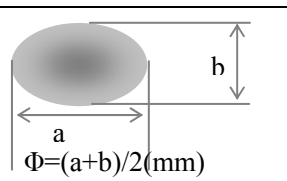
Inspection items			Judgment standard			
			Category		Acceptable number	
					A zone	B zone
1	Black spot, White spot, Bright spot, Pinhole, Foreign Particle, Bubble and Particle in or on glass, Scratch on glass		A	$\Phi \leq 0.10$	Neglected	Neglected
			B	$0.10 < \Phi \leq 0.15$	2	
			C	$0.15 < \Phi \leq 0.20$	1	
			D	$0.20 < \Phi$	0	
			Total defects(B,C)		3	
2	Black line, White line, Bubble and Particle between polarizer and glass, Scratch on glass		A	$W \leq 0.01$	Neglected	Neglected
			B	$0.01 < W \leq 0.03$ , $L \leq 3.0$	2	
			C	$0.03 < W \leq 0.05$ , $5 L \leq 3.0$	1	
			D	$0.05 < W$	0	
			Total defects(B,C)		3	
3	Contrast variation		A	$\Phi \leq 0.2$	Neglected	Neglected
			B	$0.2 < \Phi \leq 0.3$	2	
			C	$0.3 < \Phi \leq 0.4$	1	
			D	$0.4 < \Phi$	0	
			Total defects(B,C)		3	
4	Dot defect	TFT LCD is under 3 inches	LCD Class	Defect	A zone	B zone
			A	Bright dot	1	Neglected
				Dark dot	2	
				Total	2	
			B	Bright dot	2	
				Dark dot	3	
Total	4					

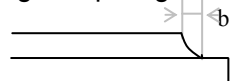
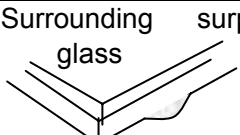
			LCD Class	Defect	A zone	B zone	C zone
		TFT LCD between 3~10.4 inches					
			A	Bright dot	1	1	Neglected
				Dark dot	1	2	
				Total	4		
			B	Bright dot	2	2	
				Dark dot	2	3	
				Total	6		
		Notes: Bright dot: in R、G、B or dark display figure, the pixel appears bright. Dark dot: in R、G、B or white display figure, the pixel appears dark. Defect area must be less than an half size of the dot.					
5	Bubble inside cell			any size		none	none
6	Polarizer defect (if Polarizer is used)	Scratch , Damage on polarizer, Particle on polarizer or between polarizer and glass.	Refer to item 1 and item 2.				
		Bubble, dent and convex	A	$\Phi \leq 0.3$	Neglected		Neglected
			B	$0.3 < \Phi \leq 0.7$	2		
			C	$0.7 < \Phi$	0		
Total defects(B,C)		2					
7	Surplus glass	Stage surplus glass 	$b \leq 0.3\text{mm}$				
		Surrounding surplus glass 	Should not influence outline dimension and assembling.				
8	Open segment or open common	Not permitted					
9	Short circuit	Not permitted					
10	False viewing direction	Not permitted					
11	Contrast ratio uneven	According to the limit specimen					
12	Crosstalk	According to the limit specimen					
13	Black /White spot(display)	Refer to item 1					
14	Black /White line(display)	Refer to item 2					

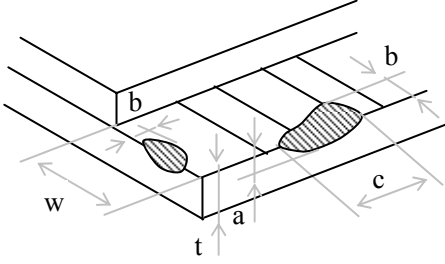
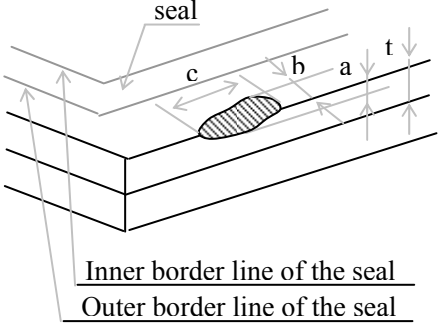
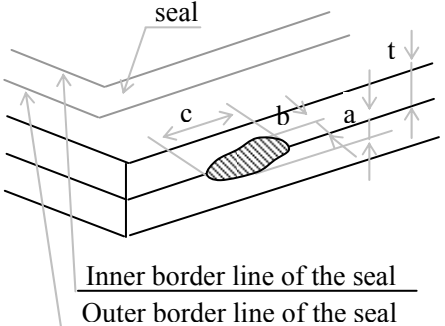
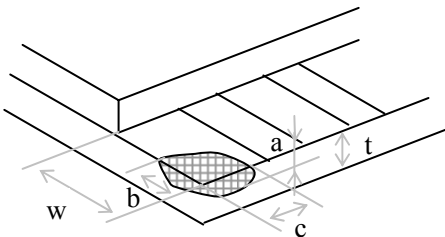
Inspection items		Judgment standard										
		Category(application: B zone)										
15	Glass defect crack	①The front of lead terminals		<table border="1"> <tr> <td>A</td> <td>If <math>a \leq t</math> and <math>b \leq 1.0</math>, <math>c</math> is not limited</td> </tr> <tr> <td>B</td> <td><math>a \leq t</math>, <math>1 \leq b \leq 2\text{mm}</math>, <math>c \leq 3\text{mm}</math></td> </tr> <tr> <td>C</td> <td>If glass crack cover alignment mark and patterns, <math>b \leq 0.5\text{mm}</math>.</td> </tr> <tr> <td>D</td> <td>Crack at two sides of lead terminals should not cover patterns and alignment mark</td> </tr> </table>	A	If $a \leq t$ and $b \leq 1.0$ , $c$ is not limited	B	$a \leq t$ , $1 \leq b \leq 2\text{mm}$ , $c \leq 3\text{mm}$	C	If glass crack cover alignment mark and patterns, $b \leq 0.5\text{mm}$ .	D	Crack at two sides of lead terminals should not cover patterns and alignment mark
		A	If $a \leq t$ and $b \leq 1.0$ , $c$ is not limited									
		B	$a \leq t$ , $1 \leq b \leq 2\text{mm}$ , $c \leq 3\text{mm}$									
		C	If glass crack cover alignment mark and patterns, $b \leq 0.5\text{mm}$ .									
D	Crack at two sides of lead terminals should not cover patterns and alignment mark											
②Surrounding crack—non-contact side		$b <$ Inner borderline of the seal										
③ Surrounding crack— contact side		$b <$ Outer borderline of the seal										
④Corner		A	$a \leq t$ , $b \leq 3.0$ , $c \leq 3.0$									
		*Glass crack should not cover patterns u and alignment mark and patterns.										

Inspection items		Judgment standard	
		Category(application: B zone)	
16	PCB defect	<p>Component soldering: No cold soldering, short, open circuit, burr, tin ball The flat encapsulation component position deviation must be less than 1/3 width of the pin (Pic.1); the sheet component deviation: Pin deviates from the pad and contact with the near components is not permitted (Pic.2)</p>	
		<p>lead defect: The lead lack must be less than 1/3 of its width; The lead burr must be less than 1/3 of the seam; Impurities connect with the near leads is not permitted</p>	
		<p>Connector soldering: Soldering tin is at contact position of the plug and socket is not permitted No foundation is scald Serious cave distortion on plug and socket contact pin is not permitted</p>	
		<p>Glue on root of the speaker receiver and motor lead: The insulative coat of the lead must join into the PCB; the protected glue must envelop to the insulative coat.</p>	

## 9. Precautions for Use of LCD Modules

### 9.1 Handling Precautions

9.1.1 The display panel is made of glass. Do not subject it to a mechanical shock by dropping it from a high place, etc.

9.1.2 If the display panel is damaged and the liquid crystal substance inside it leaks out, be sure not to get any in your mouth, if the substance comes into contact with your skin or clothes, promptly wash it off using soap and water.

9.1.3 Do not apply excessive force to the display surface or the adjoining areas since this may cause the color tone to vary.

9.1.4 The polarizer covering the display surface of the LCD module is soft and easily scratched. Handle this polarizer carefully.

9.1.5 If the display surface is contaminated, breathe on the surface and gently wipe it with a soft dry cloth. If still not completely clear, moisten cloth with one of the following solvents:

- Isopropyl alcohol
- Ethyl alcohol

Solvents other than those mentioned above may damage the polarizer.

Especially, do not use the following:

- Water
- Ketone
- Aromatic solvents

9.1.6 Do not attempt to disassemble the LCD Module.

9.1.7 If the logic circuit power is off, do not apply the input signals.

9.1.8 To prevent destruction of the elements by static electricity, be careful to maintain an optimum work environment.

- a. Be sure to ground the body when handling the LCD Modules.
- b. Tools required for assembly, such as soldering irons, must be properly ground.
- c. To reduce the amount of static electricity generated, do not conduct

assembly and other work under dry conditions.

- d. The LCD Module is coated with a film to protect the display surface. Be care when peeling off this protective film since static electricity may be generated.

## **9.2 Storage precautions**

9.2.1 When storing the LCD modules, avoid exposure to direct sunlight or to the light of fluorescent lamps.

9.2.2 The LCD modules should be stored under the storage temperature range. If the LCD modules will be stored for a long time, the recommend condition is:

Temperature :         $0^{\circ}\text{C} \sim 40^{\circ}\text{C}$

Relatively humidity:  $\leq 80\%$

9.2.3 The LCD modules should be stored in the room without acid, alkali and harmful gas.

**9.3 The LCD modules should be no falling and violent shocking during transportation, and also should avoid excessive press, water, damp and sunshine.**