

- Low $r_{DS(on)}$. . . 1 Ω Typ
- Output Short-Circuit Protection
- Avalanche Energy . . . 75 mJ
- Eight 350-mA DMOS Outputs
- 50-V Switching Capability
- Devices Are Cascadable
- Low Power Consumption

description

The TPIC6A595 is a monolithic, high-voltage, high-current power logic 8-bit shift register designed for use in systems that require relatively high load power. The device contains a built-in voltage clamp on the outputs for inductive transient protection. Power driver applications include relays, solenoids, and other medium-current or high-voltage loads. Each open-drain DMOS transistor features an independent chopping current-limiting circuit to prevent damage in the case of a short circuit.

This device contains an 8-bit serial-in, parallel-out shift register that feeds an 8-bit, D-type storage register. Data transfers through both the shift and storage registers on the rising edge of the shift-register clock (SRCK) and the register clock (RCK), respectively. The storage register transfers data to the output buffer when shift-register clear (SRCLR) is high. When SRCLR is low, the input shift register is cleared. When output enable (\bar{G}) is held high, all data in the output buffers is held low and all drain outputs are off. When \bar{G} is held low, data from the storage register is transparent to the output buffers. The serial output (SER OUT) allows for cascading of the data from the shift register to additional devices.

Outputs are low-side, open-drain DMOS transistors with output ratings of 50 V and a 350-mA continuous sink current capability. When data in the output buffers is low, the DMOS-transistor outputs are off. When data is high, the DMOS-transistor outputs have sink current capability.

Separate power ground (PGND) and logic ground (LGND) terminals are provided to facilitate maximum system flexibility. All PGND terminals are internally connected, and each PGND terminal must be externally connected to the power system ground in order to minimize parasitic impedance. A single-point connection between LGND and PGND must be made externally in a manner that reduces crosstalk between the logic and load circuits.

The TPIC6A595 is offered in a thermally-enhanced dual-in-line (NE) package and a wide-body surface-mount (DW) package. The TPIC6A595 is characterized for operation over the operating case temperature range of -40°C to 125°C .

NE PACKAGE
(TOP VIEW)

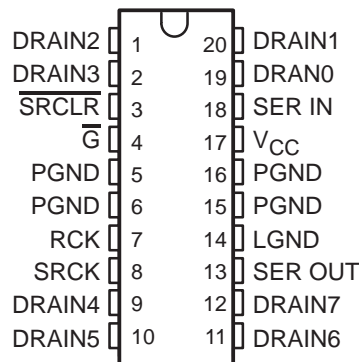

DW PACKAGE
(TOP VIEW)

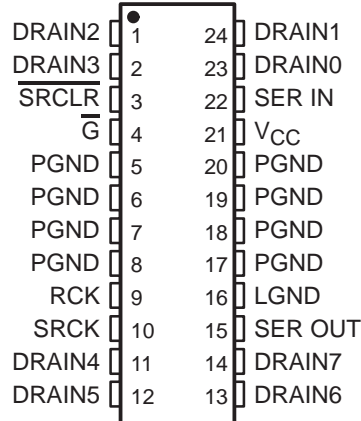

TPIC6A595 POWER LOGIC 8-BIT SHIFT REGISTER

SLIS005A – APRIL 1993 – REVISED JANUARY 1995

logic symbol†

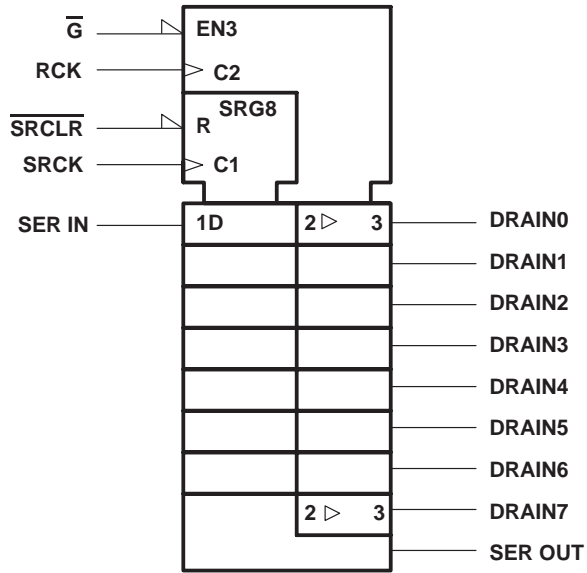

† This symbol is in accordance with ANSI/IEEE Std 91-1984 and IEC Publication 617-12.

logic diagram (positive logic)

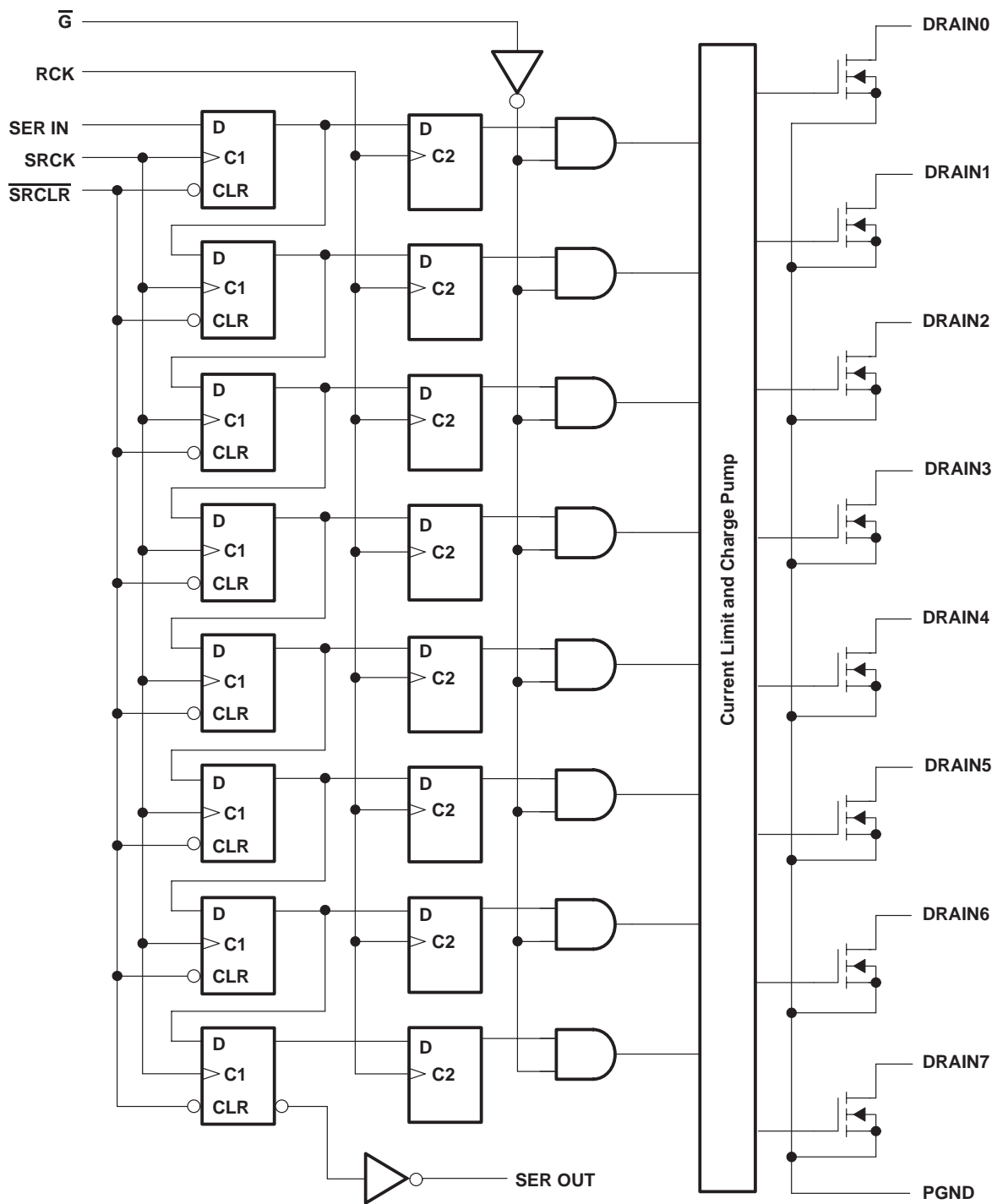

TPIC6A595 POWER LOGIC 8-BIT SHIFT REGISTER

SLIS005A – APRIL 1993 – REVISED JANUARY 1995

schematic of inputs and outputs

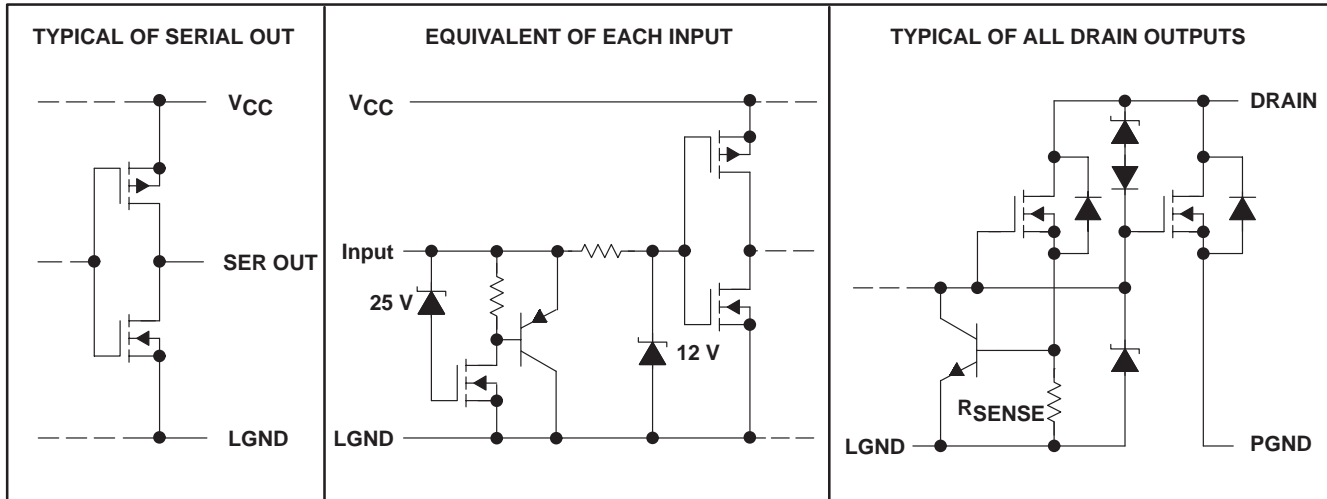

absolute maximum ratings over recommended operating case temperature range (unless otherwise noted)†

Logic supply voltage, V_{CC} (see Note 1)	7 V
Logic input voltage range, V_I	-0.3 V to 7 V
Power DMOS drain-to-source voltage, V_{DS} (see Note 2)	50 V
Continuous source-drain diode anode current	1 A
Pulsed source-drain diode anode current (see Note 3)	2 A
Pulsed drain current, each output, all outputs on, I_{Dn} , $T_A = 25^\circ\text{C}$ (see Note 3)	1.1 A
Continuous drain current, each output, all outputs on, I_{Dn} , $T_A = 25^\circ\text{C}$	350 mA
Peak drain current, single output, $T_A = 25^\circ\text{C}$ (see Note 3)	1.1 A
Single-pulse avalanche energy, E_{AS} (see Figure 6)	75 mJ
Avalanche current, I_{AS} (see Note 4)	600 mA
Continuous total dissipation	See Dissipation Rating Table
Operating case temperature range, T_C	-40°C to 125°C
Operating virtual junction temperature range, T_J	-40°C to 150°C
Storage temperature range, T_{stg}	-65°C to 150°C
Lead temperature 1,6 mm (1/16 inch) from case for 10 seconds	260°C

† Stresses beyond those listed under “absolute maximum ratings” may cause permanent damage to the device. These are stress ratings only, and functional operation of the device at these or any other conditions beyond those indicated under “recommended operating conditions” is not implied. Exposure to absolute-maximum-rated conditions for extended periods may affect device reliability.

- NOTES: 1. All voltage values are with respect to LGND and PGND.
 2. Each power DMOS source is internally connected to PGND.
 3. Pulse duration $\leq 100 \mu\text{s}$ and duty cycle $\leq 2\%$.
 4. DRAIN supply voltage = 15 V, starting junction temperature (T_{JS}) = 25°C, $L = 210 \text{ mH}$, $I_{AS} = 600 \text{ mA}$ (see Figure 6).

DISSIPATION RATING TABLE

PACKAGE	$T_C \leq 25^\circ\text{C}$ POWER RATING	DERATING FACTOR ABOVE $T_C = 25^\circ\text{C}$	$T_C = 125^\circ\text{C}$ POWER RATING
DW	1750 mW	14 mW/°C	350 mW
NE	2500 mW	20 mW/°C	500 mW

TPIC6A595
POWER LOGIC 8-BIT SHIFT REGISTER

SLIS005A – APRIL 1993 – REVISED JANUARY 1995

recommended operating conditions

	MIN	MAX	UNIT
Logic supply voltage, V_{CC}	4.5	5.5	V
High-level input voltage, V_{IH}	$0.85 V_{CC}$	V_{CC}	V
Low-level input voltage, V_{IL}	0	$0.15 V_{CC}$	V
Pulsed drain output current, $T_C = 25^\circ\text{C}$, $V_{CC} = 5\text{ V}$ (see Notes 3 and 5)	-1.8	0.6	A
Setup time, SER IN high before SRCK \uparrow , t_{su} (see Figure 2)	10		ns
Hold time, SER IN high after SRCK \uparrow , t_h (see Figure 2)	10		ns
Pulse duration, t_w (see Figure 2)	20		ns
Operating case temperature, T_C	-40	125	$^\circ\text{C}$

electrical characteristics, $V_{CC} = 5\text{ V}$, $T_C = 25^\circ\text{C}$ (unless otherwise noted)

PARAMETER	TEST CONDITIONS	MIN	TYP	MAX	UNIT
$V_{(BR)DSX}$ Drain-to-source breakdown voltage	$I_D = 1\text{ mA}$	50			V
V_{SD} Source-to-drain diode forward voltage	$I_F = 350\text{ mA}$, See Note 3		0.8	1.1	V
V_{OH} High-level output voltage, SER OUT	$I_{OH} = -20\ \mu\text{A}$	$V_{CC} - 0.1$	V_{CC}		V
	$I_{OH} = -4\text{ mA}$	$V_{CC} - 0.5$	$V_{CC} - 0.2$		
V_{OL} Low-level output voltage, SER OUT	$I_{OL} = 20\ \mu\text{A}$		0	0.1	V
	$I_{OL} = 4\text{ mA}$		0.2	0.5	
I_{IH} High-level input current	$V_I = V_{CC}$			1	μA
I_{IL} Low-level input current	$V_I = 0$			-1	μA
$I_{O(chop)}$ Output current at which chopping starts	$T_C = 25^\circ\text{C}$, See Note 5 and Figures 3 and 4	0.6	0.8	1.1	A
I_{CC} Logic supply current	$I_O = 0$, $V_I = V_{CC}$ or 0		0.5	5	mA
$I_{CC(FRQ)}$ Logic supply current at frequency	$f_{SRCK} = 5\text{ MHz}$, $V_I = V_{CC}$ or 0, $V_{CC} = 5\text{ V}$, $I_O = 0$, $C_L = 30\text{ pF}$, See Figure 7		1.3		mA
$I_{(nom)}$ Nominal current	$V_{DS(on)} = 0.5\text{ V}$, $V_{CC} = 5\text{ V}$, $I_{(nom)} = I_D$, $T_C = 85^\circ\text{C}$, See Notes 5, 6, and 7		350		mA
I_D Drain current, off-state	$V_{DS} = 40\text{ V}$, $T_C = 25^\circ\text{C}$		0.1	1	μA
	$V_{DS} = 40\text{ V}$, $T_C = 125^\circ\text{C}$		0.2	5	
$r_{DS(on)}$ Static drain-source on-state resistance	$I_D = 350\text{ mA}$, $T_C = 25^\circ\text{C}$	See Notes 5 and 6 and Figures 10 and 11	1	1.5	Ω
	$I_D = 350\text{ mA}$, $T_C = 125^\circ\text{C}$		1.7	2.5	
	$I_D = 350\text{ mA}$, $T_C = 40^\circ\text{C}$				

- NOTES: 3. Pulse duration $\leq 100\ \mu\text{s}$ and duty cycle $\leq 2\%$.
5. Technique should limit $T_J - T_C$ to 10°C maximum.
6. These parameters are measured with voltage-sensing contacts separate from the current-carrying contacts.
7. Nominal current is defined for a consistent comparison between devices from different sources. It is the current that produces a voltage drop of 0.5 V at $T_C = 85^\circ\text{C}$.



TPIC6A595

POWER LOGIC 8-BIT SHIFT REGISTER

SLIS005A – APRIL 1993 – REVISED JANUARY 1995

switching characteristics, $V_{CC} = 5\text{ V}$, $T_C = 25^\circ\text{C}$

PARAMETER		TEST CONDITIONS	MIN	TYP	MAX	UNIT
t_{PHL}	Propagation delay time, high-to-low-level output from \overline{G}	$C_L = 30\text{ pF}$, $I_D = 350\text{ mA}$, See Figures 1, 2, and 12		30		ns
t_{PLH}	Propagation delay time, low-to-high-level output from \overline{G}			125		ns
t_r	Rise time, drain output			60		ns
t_f	Fall time, drain output			30		ns
t_a	Reverse-recovery-current rise time	$I_F = 350\text{ mA}$, $di/dt = 20\text{ A}/\mu\text{s}$, See Notes 5 and 6 and Figure 5		100		ns
t_{rr}	Reverse-recovery time			300		ns

NOTES: 5. Technique should limit $T_J - T_C$ to 10°C maximum.
6. These parameters are measured with voltage-sensing contacts separate from the current-carrying contacts.

thermal resistance

PARAMETER		TEST CONDITIONS	MIN	MAX	UNIT
$R_{\theta JC}$	Thermal resistance, junction-to-case	DW		10	$^\circ\text{C}/\text{W}$
		NE		10	
$R_{\theta JA}$	Thermal resistance, junction-to-ambient	DW		50	$^\circ\text{C}/\text{W}$
		NE		50	



PARAMETER MEASUREMENT INFORMATION

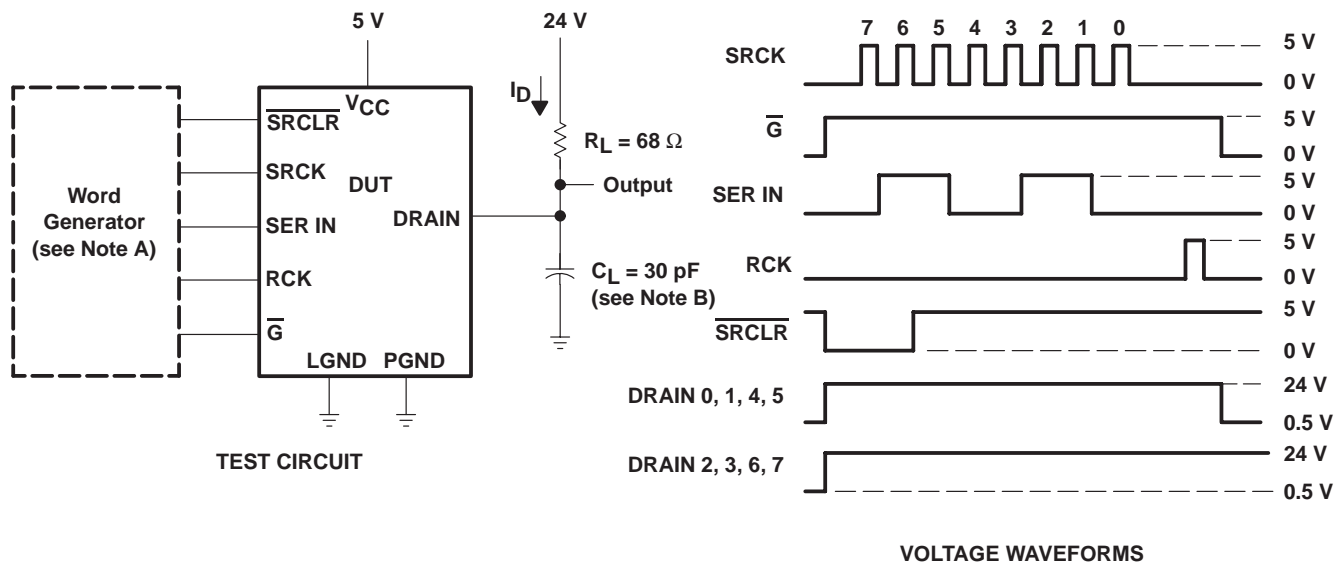

- NOTES: A. The word generator has the following characteristics: $t_r \leq 10$ ns, $t_f \leq 10$ ns, $t_w = 300$ ns, pulsed repetition rate (PRR) = 5 kHz, $Z_O = 50 \Omega$.
B. C_L includes probe and jig capacitance.

Figure 1. Resistive Load Operation

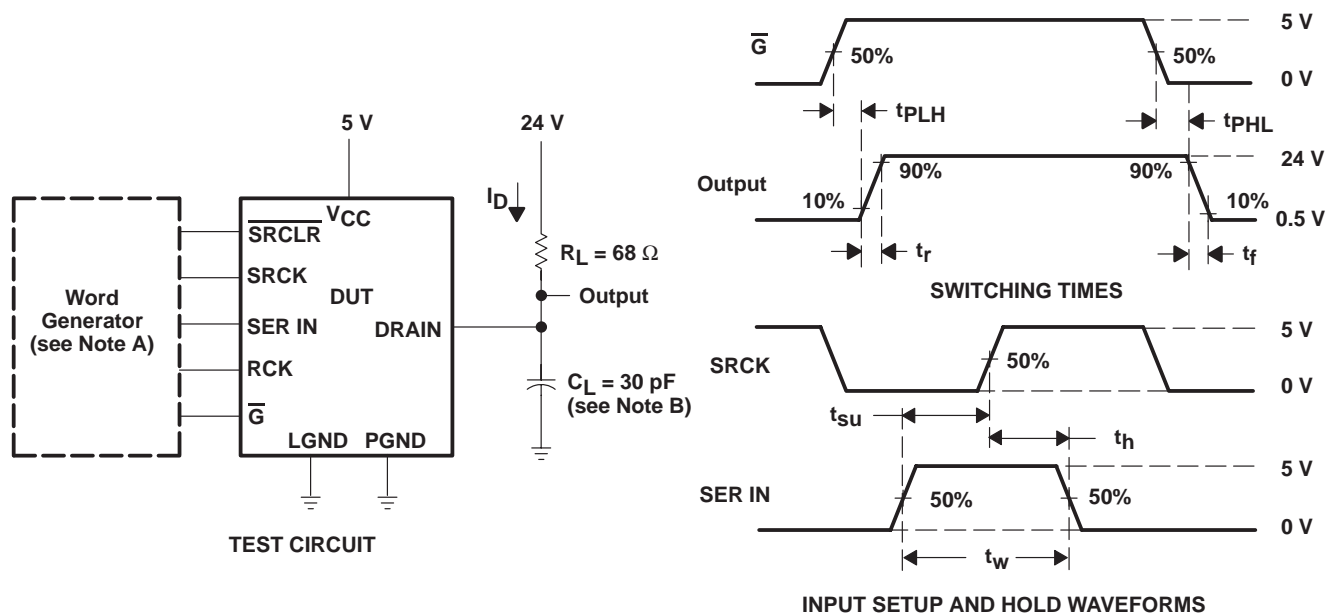

- NOTES: A. The word generator has the following characteristics: $t_r \leq 10$ ns, $t_f \leq 10$ ns, $t_w = 300$ ns, pulsed repetition rate (PRR) = 5 kHz, $Z_O = 50 \Omega$.
B. C_L includes probe and jig capacitance.

Figure 2. Test Circuit, Switching Times, and Voltage Waveforms

TPIC6A595 POWER LOGIC 8-BIT SHIFT REGISTER

SLIS005A – APRIL 1993 – REVISED JANUARY 1995

PARAMETER MEASUREMENT INFORMATION

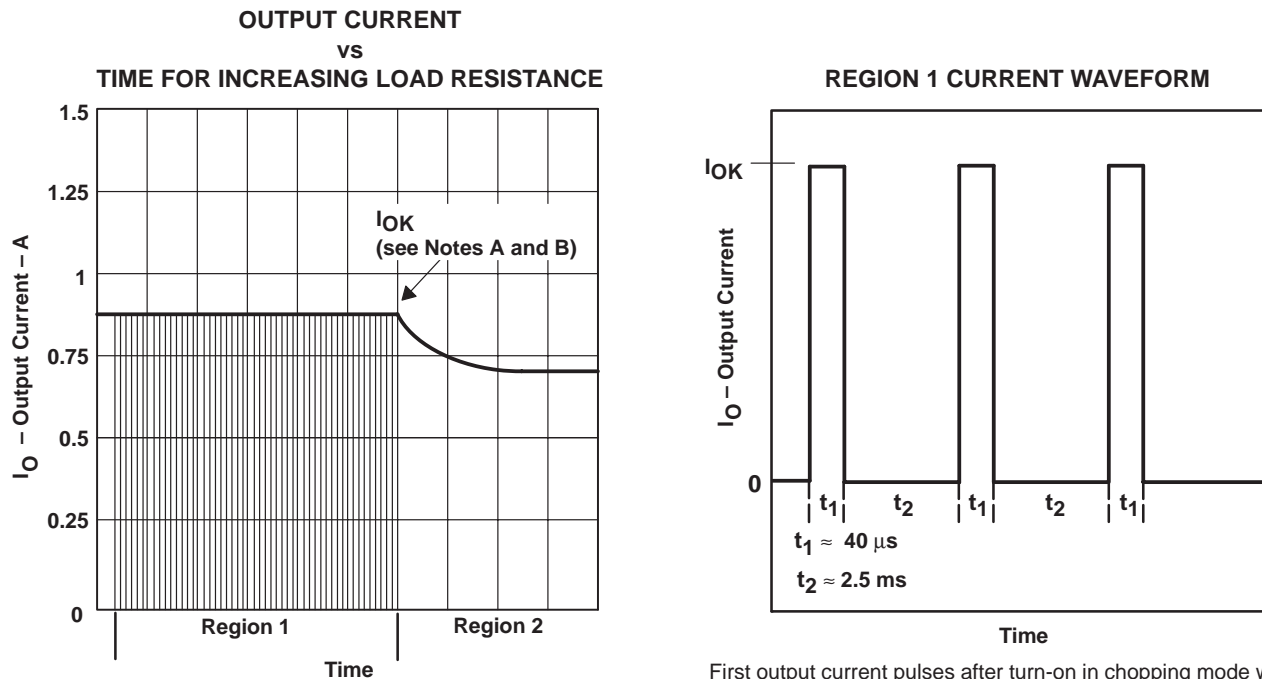

First output current pulses after turn-on in chopping mode with resistive load.

- NOTES: A. Figure 3 illustrates the output current characteristics of the device energizing a load having initially low, increasing resistance, e.g., an incandescent lamp. In region 1, chopping occurs and the peak current is limited to I_{OK} . In region 2, output current is continuous. The same characteristics occur in reverse order when the device energizes a load having an initially high, decreasing resistance.
- B. Region 1 duty cycle is approximately 2%.

Figure 3. Chopping-Mode Characteristics

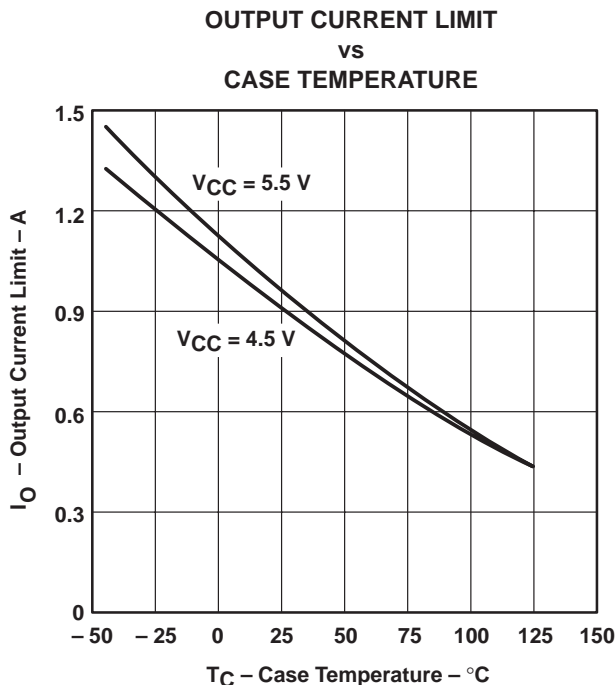
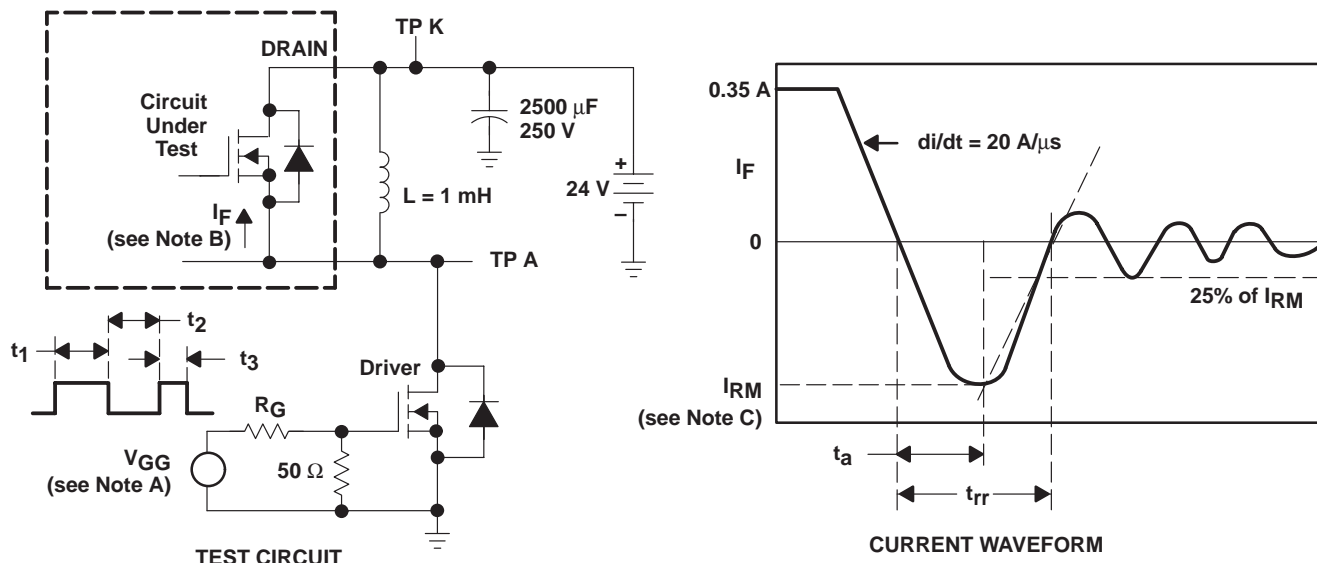

Figure 4



PARAMETER MEASUREMENT INFORMATION



- NOTES: A. The V_{GG} amplitude and R_G are adjusted for $di/dt = 20 \text{ A}/\mu\text{s}$. A V_{GG} double-pulse train is used to set $I_F = 0.35 \text{ A}$, where $t_1 = 10 \mu\text{s}$, $t_2 = 7 \mu\text{s}$, and $t_3 = 3 \mu\text{s}$.
 B. The DRAIN terminal under test is connected to the TP K test point. All other terminals are connected together and connected to the TP A test point.
 C. I_{RM} = maximum recovery current

Figure 5. Reverse-Recovery-Current Test Circuit and Waveforms of Source-Drain Diode

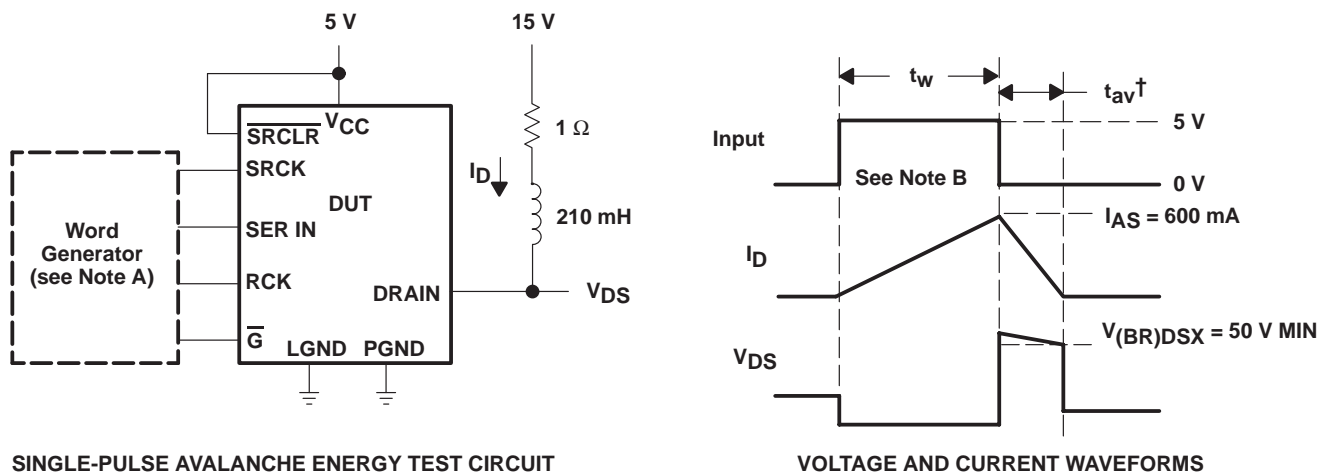

- † Non JEDEC symbol for avalanche time.
 NOTES: A. The word generator has the following characteristics: $t_r \leq 10 \text{ ns}$, $t_f \leq 10 \text{ ns}$, $Z_0 = 50 \Omega$.
 B. Input pulse duration, t_w , is increased until peak current $I_{AS} = 600 \text{ mA}$.
 Energy test level is defined as $E_{AS} = (I_{AS} \times V_{(BR)DSX} \times t_{av})/2 = 75 \text{ mJ}$.

Figure 6. Single-Pulse Avalanche Energy Test Circuit and Waveforms

TPIC6A595 POWER LOGIC 8-BIT SHIFT REGISTER

SLIS005A – APRIL 1993 – REVISED JANUARY 1995

TYPICAL CHARACTERISTICS

**SUPPLY CURRENT
vs
FREQUENCY**

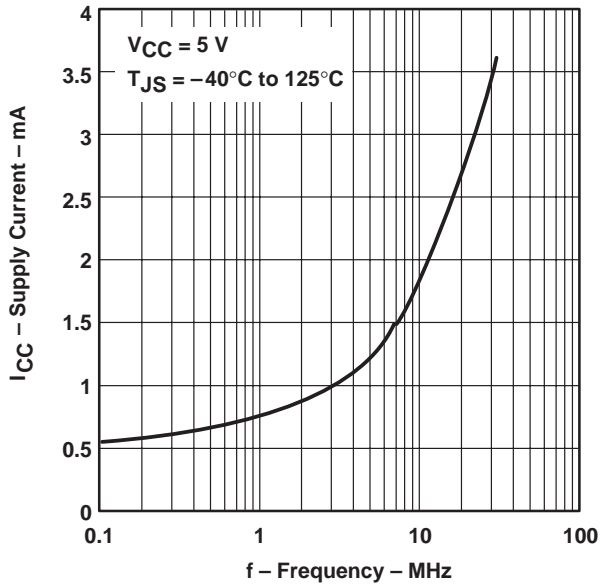

Figure 7

**MAXIMUM CONTINUOUS
DRAIN CURRENT OF EACH OUTPUT
vs
NUMBER OF OUTPUTS CONDUCTING
SIMULTANEOUSLY**

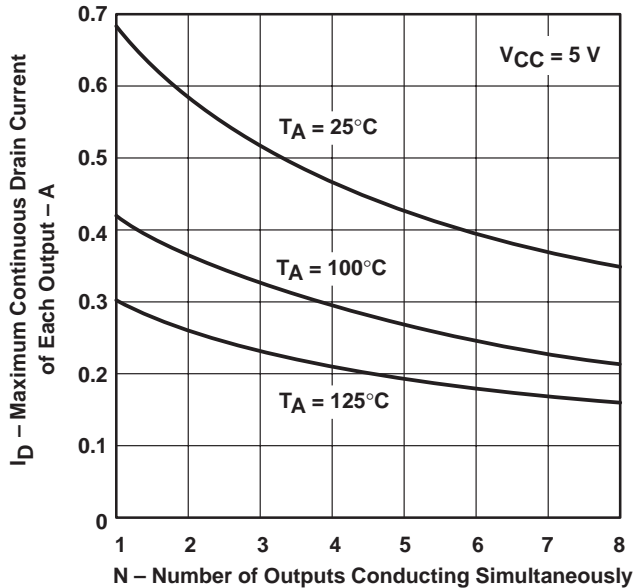

Figure 8

**MAXIMUM PEAK DRAIN CURRENT
OF EACH OUTPUT
vs
NUMBER OF OUTPUTS CONDUCTING
SIMULTANEOUSLY**

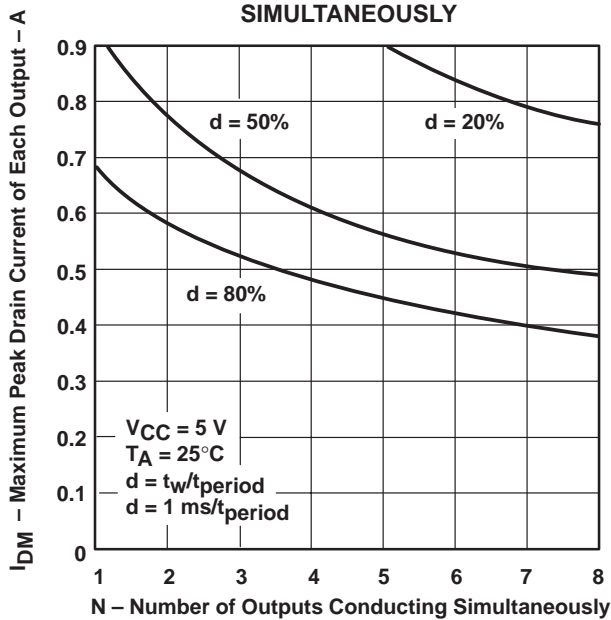

Figure 9

**STATIC DRAIN-SOURCE ON-STATE RESISTANCE
vs
DRAIN CURRENT**

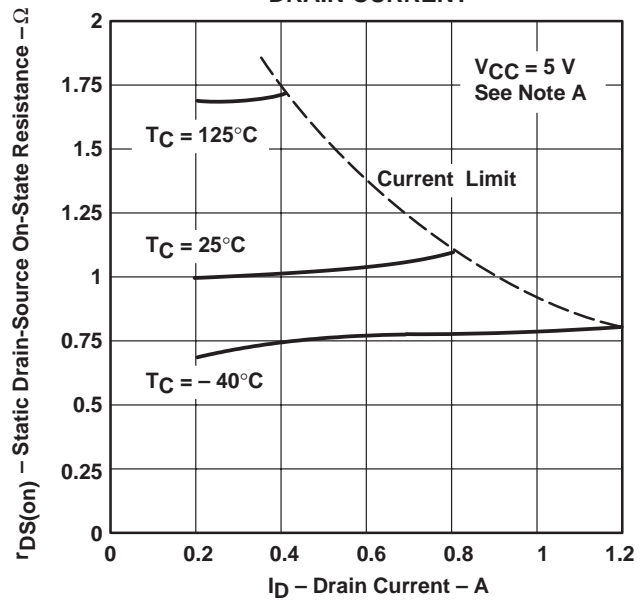

Figure 10

NOTE A: Technique should limit $T_J - T_C$ to 10°C maximum.

TYPICAL CHARACTERISTICS

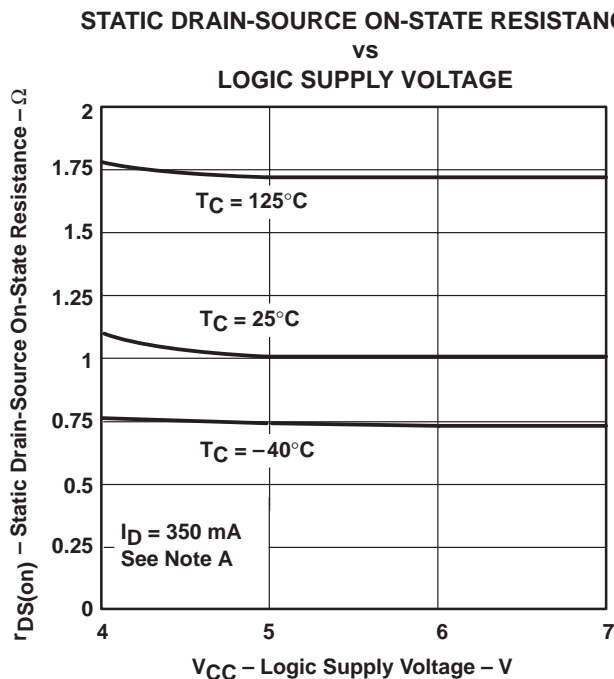

Figure 11

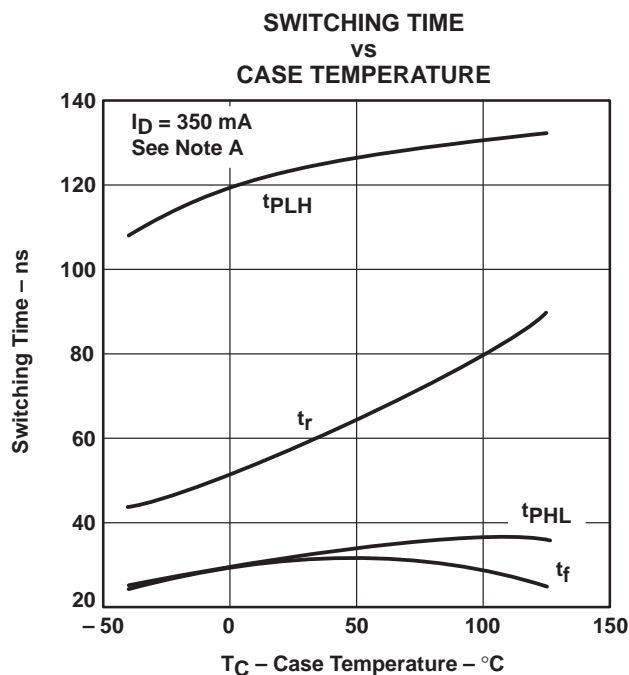
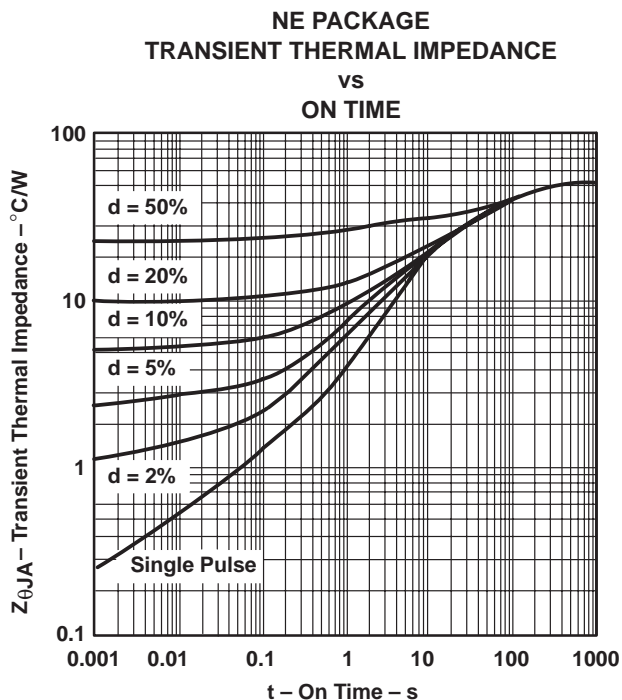

Figure 12

NOTE A: Technique should limit $T_J - T_C$ to 10°C maximum.

THERMAL INFORMATION



The single-pulse curve represents measured data. The curves for various pulse durations are based on the following equation:

$$Z_{\theta JA} = \left| \frac{t_w}{t_c} \right| R_{\theta JA} + \left| 1 - \frac{t_w}{t_c} \right| Z_{\theta}(t_w + t_c) + Z_{\theta}(t_w) - Z_{\theta}(t_c)$$

Where:

$Z_{\theta}(t_w)$ = the single-pulse thermal impedance for $t = t_w$ seconds

$Z_{\theta}(t_c)$ = the single-pulse thermal impedance for $t = t_c$ seconds

$Z_{\theta}(t_w + t_c)$ = the single-pulse thermal impedance for $t = t_w + t_c$ seconds

$$d = t_w/t_c$$

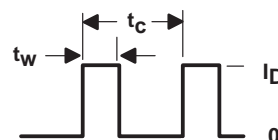

Figure 13

IMPORTANT NOTICE

Texas Instruments and its subsidiaries (TI) reserve the right to make changes to their products or to discontinue any product or service without notice, and advise customers to obtain the latest version of relevant information to verify, before placing orders, that information being relied on is current and complete. All products are sold subject to the terms and conditions of sale supplied at the time of order acknowledgment, including those pertaining to warranty, patent infringement, and limitation of liability.

TI warrants performance of its products to the specifications applicable at the time of sale in accordance with TI's standard warranty. Testing and other quality control techniques are utilized to the extent TI deems necessary to support this warranty. Specific testing of all parameters of each device is not necessarily performed, except those mandated by government requirements.

Customers are responsible for their applications using TI components.

In order to minimize risks associated with the customer's applications, adequate design and operating safeguards must be provided by the customer to minimize inherent or procedural hazards.

TI assumes no liability for applications assistance or customer product design. TI does not warrant or represent that any license, either express or implied, is granted under any patent right, copyright, mask work right, or other intellectual property right of TI covering or relating to any combination, machine, or process in which such products or services might be or are used. TI's publication of information regarding any third party's products or services does not constitute TI's approval, license, warranty or endorsement thereof.

Reproduction of information in TI data books or data sheets is permissible only if reproduction is without alteration and is accompanied by all associated warranties, conditions, limitations and notices. Representation or reproduction of this information with alteration voids all warranties provided for an associated TI product or service, is an unfair and deceptive business practice, and TI is not responsible nor liable for any such use.

Resale of TI's products or services with statements different from or beyond the parameters stated by TI for that product or service voids all express and any implied warranties for the associated TI product or service, is an unfair and deceptive business practice, and TI is not responsible nor liable for any such use.

Also see: [Standard Terms and Conditions of Sale for Semiconductor Products](http://www.ti.com/sc/docs/stdterms.htm). www.ti.com/sc/docs/stdterms.htm

Mailing Address:

Texas Instruments
Post Office Box 655303
Dallas, Texas 75265

This datasheet has been download from:

www.datasheetcatalog.com

Datasheets for electronics components.