



Data Sheet

Stepper motor driver IC SAA 1027

RS stock number 300-237

The RS SAA1027 is a bipolar integrated circuit intended for driving a 4-phase two stator stepper motor. The circuit consists of a bidirectional 4-state counter and a code converter to drive the four outputs in the sequence required for driving a stepper motor.

It features high noise immunity inputs, clockwise and anticlockwise operation, a reset facility and high current outputs that are protected against damage by voltage overshoots.

For further details of RS stepper motors please see Data Sheet 7017.

Absolute maximum ratings

Supply voltage _____ 18VDC

Input voltage, all inputs _____ 18V

Current into pin 4 _____ 120mA

Output current _____ 500mA

Storage temperature range _____ -40°C to +125°C

Operating temperature range _____ -20°C to +70°C

Features

- High noise immunity inputs
- Clockwise and counter-clockwise rotation
- Reset facility
- High output current
- Outputs protected against damage by overshoots.

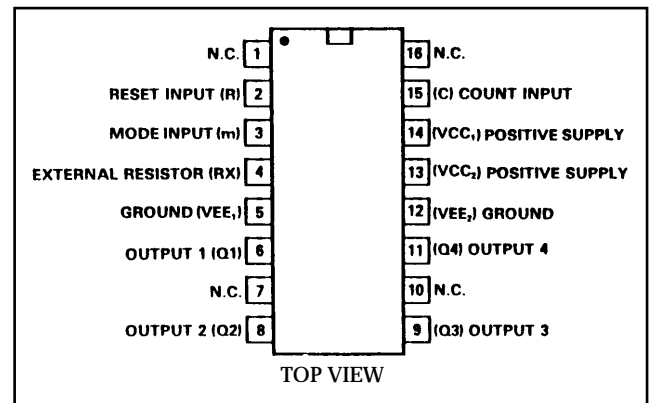

Electrical characteristics

$V_{CC} = 9,5$ to 18V; $V_{EE} = 0V$; $T_{amb} = -20$ to +70°C unless otherwise specified

Parameter	Symbol	Min.	Typ.	Max.	Unit
Supply V_{CC1} and V_{CC2} (pins 14 and 13) Supply current $V_{CC1} = 12V$ unloaded; all inputs HIGH; pin 4 open	I_{CC}	2	4,5	6,5	mA
Inputs C, M and R (pins 15, 3 and 2) Input voltage HIGH	V_{IH}	7,5	-	-	V
LOW	V_{IL}	-	-	4,5	V
Input current HIGH	I_{IH}	-	1	-	μA
LOW	$-I_{IL}$	-	30	-	μA
External resistor pin RX (pin 4) Voltage at RX at $V_{CC} = 12V \pm 15\%$; $R_X = 130\Omega \pm 5\%$	V_{RX}	3	-	4,5	V
Outputs Q1 to Q4 Output voltage LOW at $I_{OL} = 350mA$	V_{OL}	-	500	1000	mV
at $I_{OL} = 500mA$	V_{OL}	-	700	-	mV
Output current LOW	I_{OL}	-	-	500*	mA
HIGH at $V_Q = 18V$	$-I_{OH}$	-	-	50	μA

* See Figures 3 and 4.

Figure 1 Block diagram

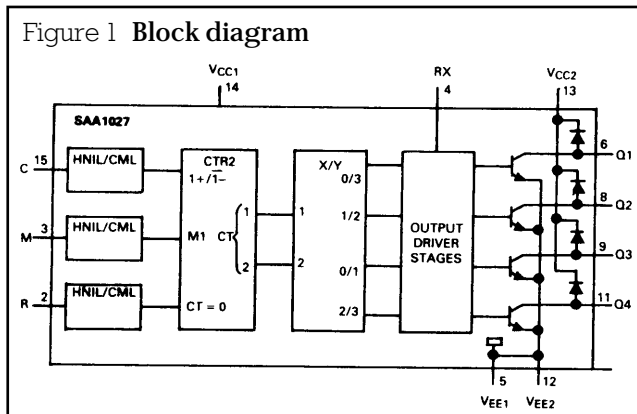

The blocks marked HNIL/CML are high noise immunity input stages, the block marked CTR2 is a bidirectional synchronous 2-bit (4-state) counter and the block marked X/Y is a code converter. C is the count input, M the mode input to select forward or reverse counting and R is the reset input which resets the counter to content zero.

Functional description

Count input C (pin 15)

The outputs change state after each L to H signal transition at the count input.

Mode input M (pin 3)

With the mode input the sequence of output signals, and hence the direction of rotation of the stepping motor, can be chosen, as shown in the following table.

Counting sequence	M = L				M = H			
	Q1	Q2	Q3	Q4	Q1	Q2	Q3	Q4
0	L	H	L	H	L	H	L	H
1	H	L	L	H	L	H	H	L
2	H	L	H	L	H	L	H	L
3	L	H	H	L	H	L	L	H
0	L	H	L	H	L	H	L	H

Reset input R (pin 2)

A LOW level at the R input resets the counter to content zero. The outputs take on the levels shown in the upper and lower line of the table above.

If this facility is not used the R pin should be connected to the supply.

External resistor pin RX (pin 4)

The external resistor R4 connected to RX sets the base current of the output transistors. Its value has to be chosen in accordance with the required output current (Figure 5).

Outputs Q1 to Q4 (pins 6, 8, 9 and 11)

The circuit has open-collector outputs. To prevent damage by an overshooting output voltage the outputs are protected by diodes connected to V_{CC2}, pin 13. High output currents mainly determine the total dissipation, (Figure 3).

Figure 2 Waveform diagram

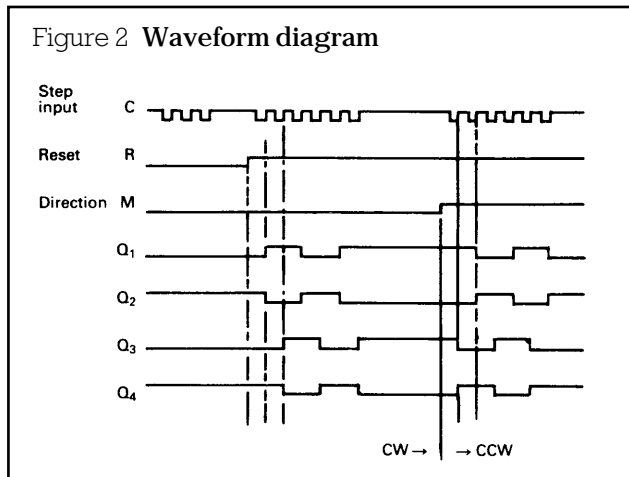

Figure 3 Total power dissipation P_{tot} as a function of output current I_{OL}

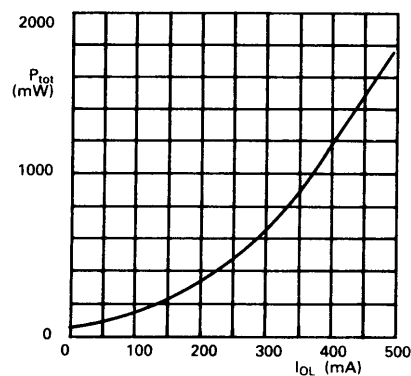

Figure 4 Power derating curve

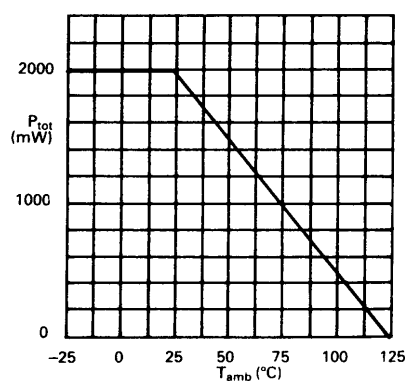
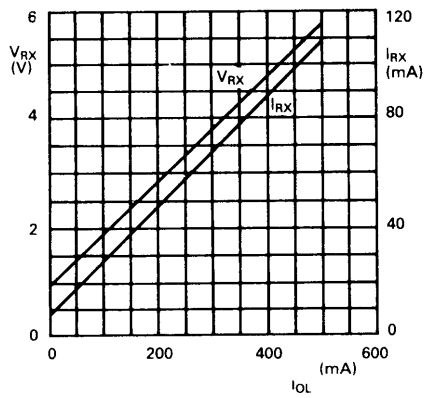
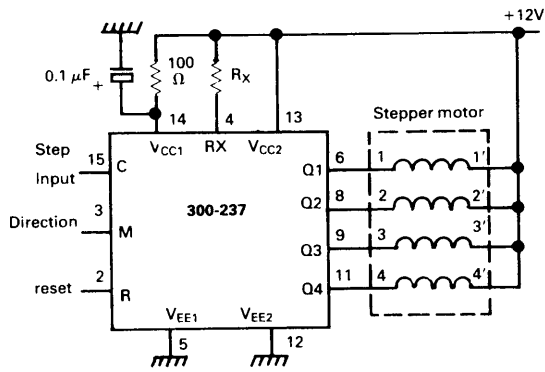

Figure 5 Current I_{RX} into RX and voltage V_{RX} on RX as a function of required output current I_{OL}



Applications

Figure 6 Typical application of the SAA 1027 as a stepper motor driver



The information provided in **RS** technical literature is believed to be accurate and reliable; however, RS Components assumes no responsibility for inaccuracies or omissions, or for the use of this information, and all use of such information shall be entirely at the user's own risk.
No responsibility is assumed by RS Components for any infringements of patents or other rights of third parties which may result from its use.
Specifications shown in RS Components technical literature are subject to change without notice.
