

How to Use MMC/SDC

Update: June 11, 2008



Now *SD Memory Card* (Secure Digital Memory Card) is the most popular memory card for mobile equipments. The SD Memory Card (SDC below) was developed as upper-compatible to *Multi Media Card* (MMC below) so that the SDC compleant equipments can also use an MMC with a few considerations. There are also reduced size versions, such as *RS-MMC*, *miniSD* and *microSD*, with same function. The MMC/SDC has a microcontroller in it, the flash memory controls (erase, read, write and error control) are completed at inside of the memory card. The data is transferred between memory card and host controller in unit of 512 bytes per block in default, so that it can be seen like a generic hard disk drive from view point of application programs. The currenty defined file system is only FAT12/16 with FDISK partitioning rule. The FAT32 is defined for only high capacity ($\geq 4G$) cards.

This page describes the basic knowledge and miscellaneous things that I become aware, on using MMC/SDC with small embedded system. I believe that this information must be a useful getting started notes for people who is going to begin to enjoy MMC/SDC.

Contact Surface

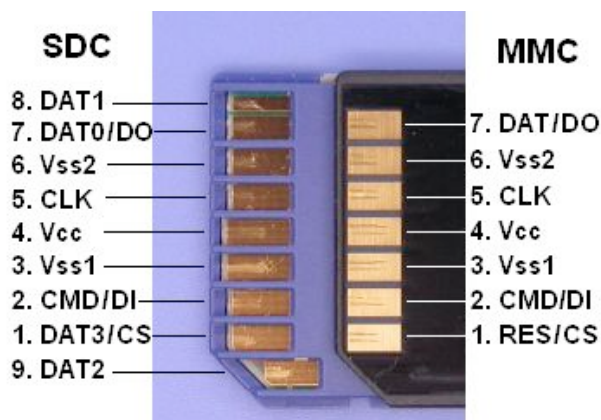

Right photo shows the contact surface of the SDC/MMC. The MMC has seven contact pads and the SDC has nine contact pads that two pads added to MMC. Three of the contacts for each occupy as power supply pins so that the effective signal numbers are four and six. Ofcourse the data transfer between the host and the card is done in clocked serial data transfer.

The working supply voltage range is indicated in OCR register and it should be read to confirm the operating voltage range. However, the supply voltage can be fixed to a proper value because the MMC/SDC works at supply voltage of 2.7 to 3.6 volts. The current consumption can reach up to several ten milliamperes, so that the host system should be able to supply 100 milliamperes at least.

SPI Mode

[SPI mode](#) is an alternative operating mode that defined to use MMC/SDC without its specific host interface. The communication protocol for the SPI mode is very simple compared to MMC/SDC native mode, the MMC/SDC can be attached via a generic SPI port or a GPIO port built in most microcontrollers. Therefore the SPI mode is suitable for low cost embedded applications. Especially, *there is no reason to use native mode for electronic handiwork as a hobby*. For SDC, the 'SPI mode 0' is defined for its SPI mode. But for MMC, it is not the SPI timing, both latch and shift actions are defined with rising edge of SCLK, but it seems work in SPI mode 0 at SPI mode. Thus *SPI Mode 0* (CPHA=0, CPOL=0) is the proper setting for MMC/SDC interface, but SPI mode 3 also works as well in most case.

Command and Response

In SPI mode, the data direction on the signal line is fixed and the data is transferred in byte oriented serial communication. The command frame from host to card is a fixed length (six bytes) packet that shown below. When a command frame is transmitted to the card, a response to the command (R1, R2 or R3) will be sent back to the host. Because data transfer is driven by serial clock generated by host, the host must continue to read bytes until receive any valid response. The command response time (NCR) is 0 to 8 bytes for SDC, 1 to 8 bytes for MMC. The CS signal must be held low during a transaction (command, response and data transfer if exist). The CRC field is optional in SPI mode, but it is required as a bit field to compose a command frame. The DI signal must be kept high during read transfer.

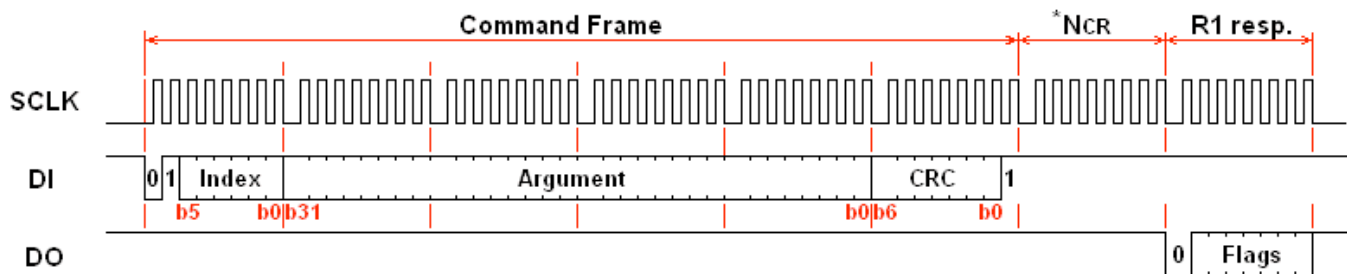

SPI Command Set

Each command is expressed in abbreviation like GO_IDLE_STATE or CMD<n>, <n> is the number of the command index and the value can be 0 to 63. Following table describes only commands that to be usually used for generic read/write and card initialization. For details on all commands, please refer to spec sheets from MMCA and SDCA.

Command Index	Argument	Response Data	Abbreviation	Description
CMD0	None(0)	R1	No GO_IDLE_STATE	Software reset.
CMD1	None(0)	R1	No SEND_OP_COND	Initiate initialization process.
ACMD41(*1) *2		R1	No APP_SEND_OP_COND	For only SDC. Initiate initialization process.
CMD8	*3	R7	No SEND_IF_COND	For only SDC V2. Check voltage range.
CMD9	None(0)	R1	Yes SEND_CSD	Read CSD register.

CMD10	None(0)	R1	Yes	SEND_CID	Read CID register.
CMD12	None(0)	R1b	No	STOP_TRANSMISSION	Stop to read data.
CMD16	Block length[31:0]	R1	No	SET_BLOCKLEN	Change R/W block size.
CMD17	Address[31:0]	R1	Yes	READ_SINGLE_BLOCK	Read a block.
CMD18	Address[31:0]	R1	Yes	READ_MULTIPLE_BLOCK	Read multiple blocks. For only MMC.
CMD23	Number of blocks[15:0]	R1	No	SET_BLOCK_COUNT	Define number of blocks to transfer with next multi-block read/write command. For only SDC. Define number of blocks to pre-erase with next multi-block write command.
ACMD23(*1)	Number of blocks[22:0]	R1	No	SET_WR_BLOCK_ERASE_COUNT	pre-erase with next multi-block write command.
CMD24	Address[31:0]	R1	Yes	WRITE_BLOCK	Write a block.
CMD25	Address[31:0]	R1	Yes	WRITE_MULTIPLE_BLOCK	Write multiple blocks.
CMD55(*1)	None(0)	R1	No	APP_CMD	Application specific command.
CMD58	None(0)	R3	No	READ_OCR	Read OCR.

*1:ACMD<n> means a command sequence of CMD55-CMD<n>.

*2: Rsv(0)[31], HCS[30], Rsv(0)[29:0]

*3: Rsv(0)[31:12], Supply Voltage(1)[11:8], Check Pattern(0xAA)[7:0]

SPI Response

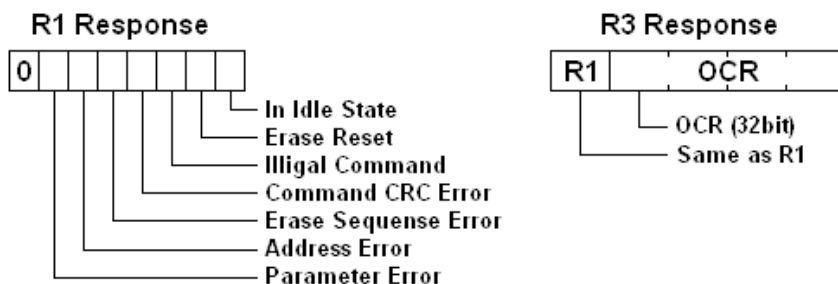

There are three command response formats, *R1*, *R2* and *R3*, depends on the command index. A byte of response *R1* is returned for most commands. The bit field of *R1* response is shown in right image, the value 0x00 means successful. When any error occurred, corresponding bit in the response will be set. The *R3* response (*R1* + *OCR*) is for only CMD58.

Some commands take a time longer than *NCR* and it responds *R1b*. It is an *R1* response followed by busy flag (*DO* is held low as long as internal process is in progress). The host controller should wait for end of the process until 0xFF is received.

Initialization Procedure for SPI Mode

After power on reset, MMC/SDC enters its native operating mode. To put it SPI mode, follwing procedure must be performed.

Power ON (Inserion)

After supply voltage reached 2.2 volts, wait for a millisecond at least. *Set DI and CS high and apply more*

than 74 clock pulses to *SCLK* and the card will go ready to accept native commands.

Software Reset

Set SPI clock rate between 100kHz and 400kHz and then send a *CMD0* with CS low to reset the card. The card samples CS signal when a *CMD0* is received. If the CS signal is low, the card enters SPI mode. Since the *CMD0* must be sent as a native command, the CRC field must have a valid value. When once the card enters SPI mode, the CRC feature is disabled and the CRC is not checked, so that command transmission routine can be written with the hardcoded CRC value that valid for only *CMD0* and *CMD8*. When the *CMD0* is accepted, the card will enter idle state and respond R1 response with In Idle State bit (0x01). The CRC feature can also be switched with *CMD59*.

Initialization

In idle state, the card accepts only *CMD0*, *CMD1* and *CMD58*. Any other commands will be rejected. In this time, check working voltage range indicated in the OCR. In case of the system supply voltage is out of working voltage range, the card must be rejected. The card initiates initialization when a *CMD1* is detected. To poll end of the initialization, the host controller must send *CMD1* and check the response until end of the initialization. When the card is initialized successfully, In Idle State bit in the R1 response is cleared (R1 resp changes 0x01 to 0x00). The initialization process can take *several hundred milliseconds* (large cards tend to longer), so that this is a consideration to determine the time out value. After the card has initialized, generic read/write commands will be able to be accepted.

Because *ACMD41* instead of *CMD1* is recommended for SDC, send *ACMD41* first and when it is rejected, retry with *CMD1*, is ideal, to support both type of the card.

The SPI clock rate should be changed to fast as possible to optimize the read/write performance. The *TRAN_SPEED* field in the CSD indicates the maximum clock rate of the card. The maximum clock rate is 20MHz for MMC, 25MHz for SDC in most case. Note that the clock rate can also be fixed to 20/25MHz in SPI mode because there is no open-drain condition that restricts the clock rate.

The initial block length can be set larger than 512 at 2GB card, so that the block size should be re-initialized with *CMD16* if needed.

How to support SDC Ver2 and high capacity cards

After the card enters idle state with a *CMD0*, send a *CMD8* with 0x1AA and correct CRC before initiate initialization. When the *CMD8* is rejected with an illegal command error, the card is SDC V1 or MMC. When the *CMD8* is accepted, R7 response (R1 + 32 bit return value) will be returned. The lower 12 bits in the return value 0x1AA means that the card is SDC V2 and can work at voltage range of 2.7 to 3.6 volts. If not the case, the card must be rejected. And then initiate initialization with *ACMD41* with HCS bit. After the initialization completed, read OCR and check CCS bit in the OCR. When it is set, subsequent data read/write operations that described below are commanded in block address insted of byte address. The block size is fixed to 512 bytes.

Data Transfer

Data Packet and Data Response

Data Packet

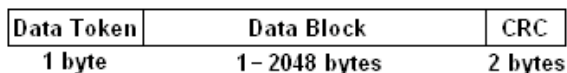

Data Token

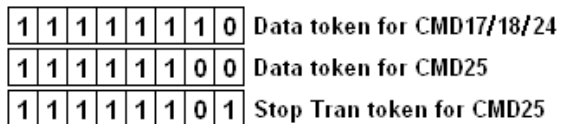

Error Token

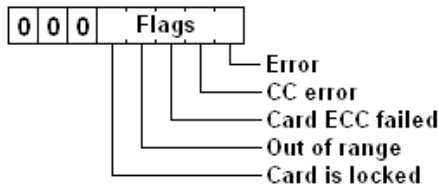

Data Response

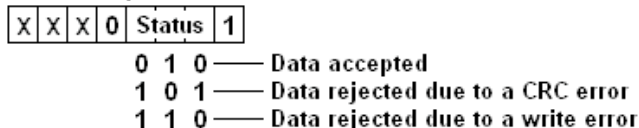

In a transaction with data transfer, one or more data blocks will be sent/received after command response. The data block is transferred as a data packet that consist of Token, Data Block and CRC. The format of the data packet is shown in right image and there are three data tokens. As for Stop Tran token that means end of multiple block write, it is used in single byte without data block and CRC.

Single Block Read

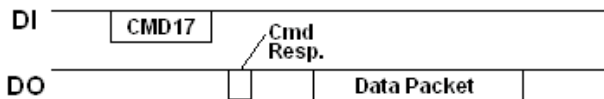

The argument specifies the location to start to read *in unit of byte or block*. The sector address specified by upper layer must be scaled properly. When a CMD17 is accepted, a read operation is initiated and the read data block will be sent to the host. After a valid data token is detected, the host controller receives following data field and two byte CRC. The CRC bytes must be flushed even if it is not needed. If any error occurred during the read operation, an error token will be returned instead of data packet.

Multiple Block Read

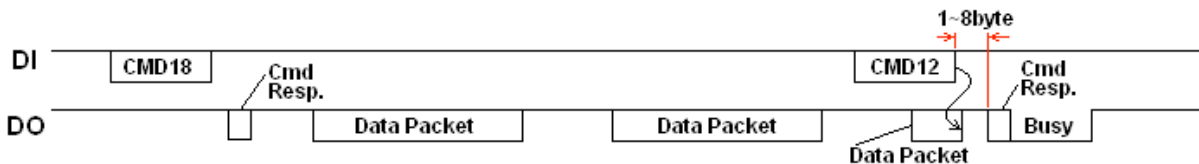

The Multiple Block Read command reads multiple blocks in sequence from the specified address. When number of transfer blocks has not been specified before this command, the transaction will be initiated as an open-ended multiple block read, the read operation will continue until stopped with a CMD12. The received byte immediately following CMD12 is a stuff byte, it should be discarded before receive the response of the CMD12.

Single Block Write

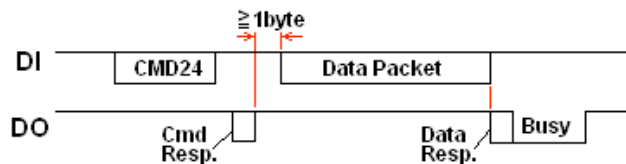

When a write command is accepted, the host controller sends a data packet to the card after a byte space. The packet format is same as Block Read command. The CRC field can have any invalid value unless the CRC function is enabled. When a data packet has been sent, the card responds a Data Response immediately following the data packet. The data response trails a busy flag to process the write operation. Most cards cannot change write block size and it is fixed to 512.

In principle of the SPI mode, the CS signal must be asserted during a transaction, however there is an exception to this rule. When the card is busy, the host controller can deassert CS to release SPI bus for any other SPI devices. The card will drive DO signal low again when reselect it during internal process is in progress. Therefore a preceding busy check (wait ready immediately before command and data packet) instead of post wait can eliminate waste wait time. In addition the internal process is initiated a byte after the data response, this means eight clocks are required to initiate internal write operation. The state of CS signal during the eight clocks is negligible so that it can be done by bus release process described below.

Multiple Block Write

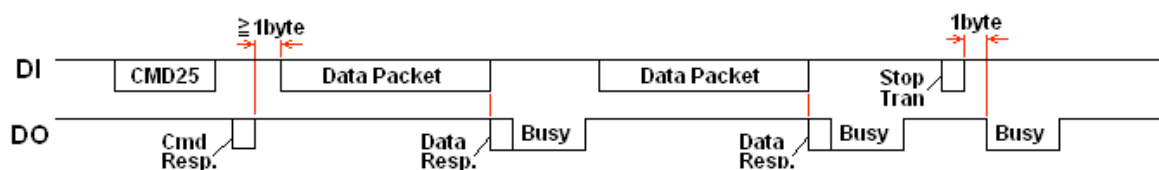

The Multiple Block Read command writes multiple blocks in sequence from the specified address. When number of transfer blocks has not been specified before this command, the transaction will be initiated as an open-ended multiple block write, the write operation will continue until terminated with a Stop Tran token. The busy flag will appear a byte after the Stop Tran token. As for SDC, the multiple block write transaction must be terminated with a Stop Tran token independent of pre-defined or open-ended.

Reading CSD and CID

These are same as Single Block Read except for the data block length. The CSD and CID are sent to the host as *16 byte data blocks*. For details of the CMD, CID and OCR, please refer to the MMC/SDC specs.

Consideration to Bus Floating and Hot Insertion

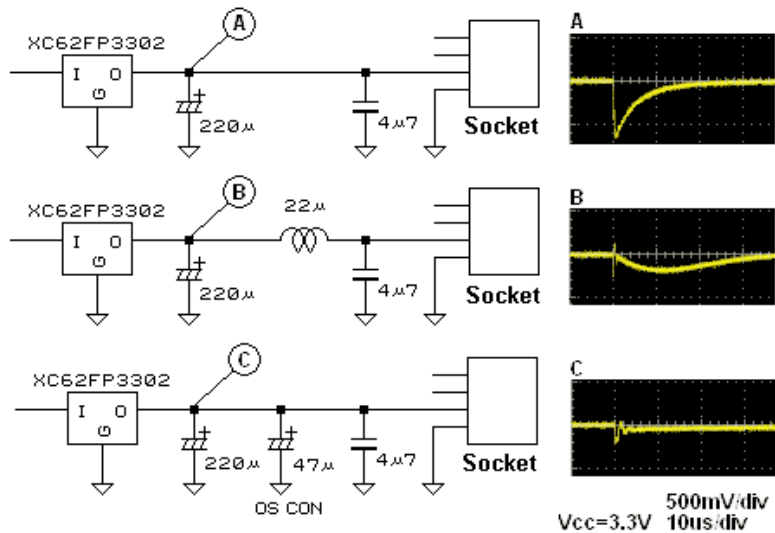

Any signal that can float should be pulled low or high properly via a resistor. This is a generic design rule on MOS devices. Because DI and DO are normally high, they should be pulled-up. According to SDC/MMC specs, from 50k to 100k ohms is recommended to the value of pull-up registers. However the clock signal is not mentioned in the SDC/MMC specs because it is always driven by host controller. When there is a possibility of floating, it should be pulled to the normal state, low.

The MMC/SDC can hot insertion/removal but some considerations to the host circuit are needed to avoid an incorrect operation. For example, if the system power supply (V_{cc}) is tied to the card socket directly, the V_{cc} will dip at the instant of contact closed due to a charge current to the capacitor that built in the card. 'A' in the right image is the scope view and it shows that occureing a voltage dip of about 600 millivolts. This is a sufficient level to trigger a brown out detector. 'B' in the right image shows that an inductor is inserted to block the surge current, the voltage dip is reduced to 200 millivolts. A low ESR capacitor, such as OS-CON, can eliminate the voltage dip dratically like shown in 'C'. However the low ESR capacitor can cause an oscillation of LDO regulator.

Cosideration on Multi-slave Configuration

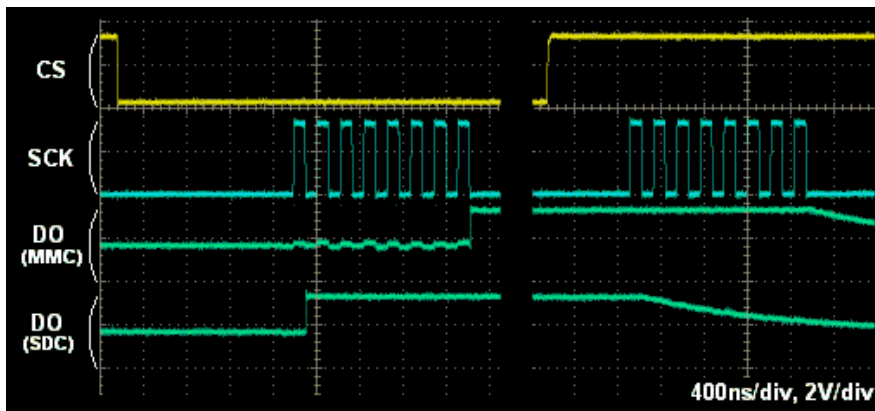

In SPI, each slave device is selected with separated CS signals, and plural devices can be attached to an SPI bus. Generic SPI slave device drives/releases its DO signal by CS signal asynchronously to share an SPI bus. However MMC/SDC drives/releases DO signal in synchronising to SCLK. There is a possibility of bus conflict when attach MMC/SDC and any other SPI slaves to an SPI bus. Right image shows the drive/release timing of MMC/SDC (DO is pulled to $1/2 V_{cc}$ to see the bus state). Therefore to make MMC/SDC release DO signal, the master device must send a byte after deasserted the CS signal.

Optimization of Write Performance

Most MMC/SDC employs [NAND Flash Memory](#) as a memory array. The NAND flash memory is cost effective and it can read/write *large* data fast, but on the other hand, there is a disadvantage that rewriting a *part* of data is inefficient. Generally the flash memory requires to erase existing data before write a new data, and minimum unit of erase operation (called erase block) is larger than write block size. The typical NAND flash memory has a block size of 512/16K bytes for write/erase operation, and recent monster card employs large block chip (2K/128K). This means that rewriting entire data in the erase block is done in the card even if write only a sector (512 bytes).

Benchmark

I examined the read/write performance of [some MMC/SDC](#) with a cheap 8 bit MCU (ATmega64 @9.2MHz) on the assumption that an embedded system *with limited memory size*. For reason of memory size, `write()` and `read()` were performed in 2048 bytes at a time. The result is: Write: 77kB/sec, Read: 328kB/sec on the [128MB SDC](#), Write: 28kB/sec, Read: 234kB/sec on the [512MB SDC](#) and Write: 182kB/sec, Read: 312kB/sec on the [128MB MMC](#).

Therefore the write performance of the 512MB SDC was very poor that one third value of 128MB SDC. Generally the read/write performance of the mass storage device increases proportional to its recording density, however it sometimes appears a tendency of opposite on the memory card. As for the MMC, it seems to be several times faster than SDC, it is not bad performance. After that time, I examined some SDCs supplied from different makers, and I found that PQI's SDC was as fast as Hitachi's MMC but Panasonic's and Toshiba's one was very poor performances.

Erase Block Size

To analyze detail of write operation, busy time (number of polling cycles) after sent a write data is typed out to console in the low level disk write function. Multiple numbers on a line indicates data blocks and a Stop Tran token that issued by a multiple block write transaction.

In result of the analysis, there is a different of internal process between 128MB SDC and 512MB SDC. The 128MB SDC rewrites erase block at end of the multiple block write transaction. The 512MB SDC seems have 4K bytes data buffer and it rewrites erase block every 4K bytes boundary. Therefore it cannot be compared directly but the processing time of rewriting an erase block can be read 3800 for 128MB SDC and the 512MB SDC takes 30000 that 8 times longer than 128MB SDC. Judging from this result, it seems the 128MB SDC uses a small block chip and the 512MB SDC uses a large block or MLC chip. Of course the larger block size decreases the performance on partial block rewriting. In 512MB SDC, only an area that 512K bytes from top of the memory is relatively fast. This can be read from write time in `close()`. It might any special processing is applied to this area for fast FAT access.

Improving Write Performance

To avoid this bottleneck and rise write performance of SDC/MMC, writing large number of blocks as possible (aligned to erase block is ideal) at a time will do. In other words, allocate large buffer memory and pass it to `fwrite()` will do. For low level disk write function, it must pre-inform number of write sectors to the card for efficient write processing. This called 'pre-defined multiple block write'. However the pre-definition command is not the same between MMC (CMD23) and SDC (ACMD23).

Well, it might a vain efforts that to rise write performance of SDC on the cheap MCUs that have only several kilobytes of RAM. CompactFlash have a good performance that ten times faster than SDC. When you require a write performance to the memory card, a CompactFlash or an MMC will be suitable better than SDC.

The memory cards are initially partitioned and formatted to align the allocation unit to the erase block. When re-partition or re-format the memory card with a system that is not compliant to MMC/SDC (this is just a PC) with no care, the optimization will be broken and the write performance might be lost. I tried to re-format 512MB SDC in FAT32 with a PC, the write performance measured in file copy was lower to one

several. Therefore the re-formatting the card should be done with MMC/SDC compliant equipments rather than PC.

Links

- [MMCA - Multimedia Card Association](#)
- [SDA - SD Card Association](#)
- [SDHC Physical Layer Spec.](#)
- [About SPI](#)
- [Generic FAT file system module](#) with sample code to control *MMC/SDSC/SDHC*

