

UNLESS OTHERWISE NOTED TOLERANCES ARE:

DIMENSIONS ARE IN INCHES	ONE PLACE DECIMALS $\pm .1$ [2.5]	THREE PLACE DECIMALS $\pm .005$ [.13]	ANGLES $\pm 2^\circ$
	TWO PLACE DECIMALS $\pm .01$ [.25]	FOUR PLACE DECIMALS $\pm .0020$ [.05]	

TITLE: .100 TERMINAL STRIP ASSEMBLY

DWG NO: ESQ-1XX-XX-X-X-XXX-XX-X-XX  
SHEET 3 OF 3

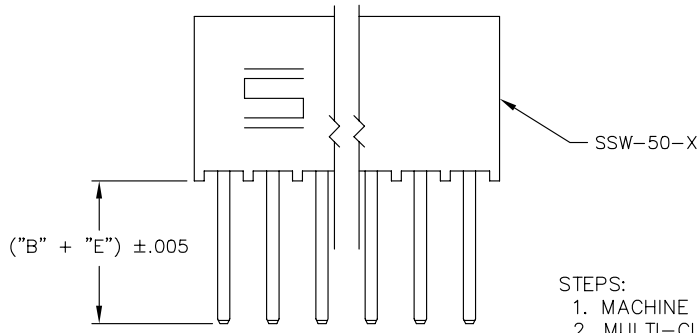

STEP 1

- STEPS:
1. MACHINE FILL SSW-50-D
  2. MULTI-CUT TSW-50-D TO POS AND MOUNT AS SHOWN.
  3. ROTO CUT TO POS.

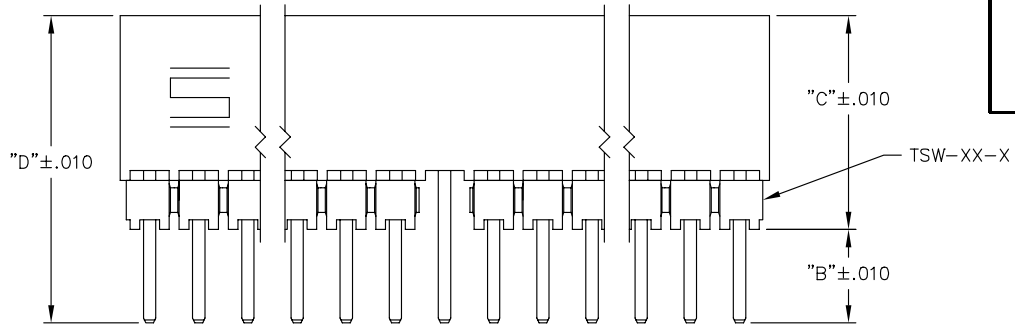

STEP 2

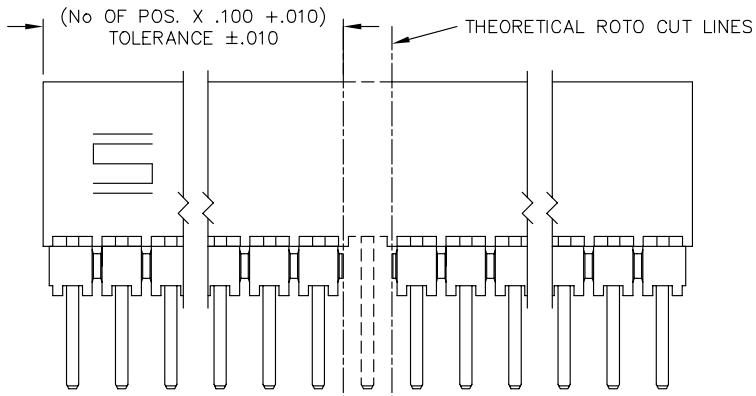

STEP 3

TABLE 2  
-MW OPTION ONLY

SUFFIX	BODY SPEC	TUBE	PLUG (2)			
-13	-S	PT-1-24-01-47	TP-24			
-14						
-23						
-24						
-33						
-34	-D	PT-1-24-02-47	TP-03			
-44						
-12				-S	PT-1-24-01-46	TP-24
-12				-D	PT-1-24-03-44	TP-03

BE

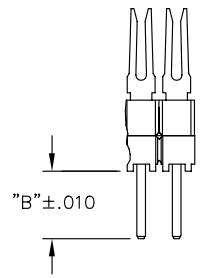

FIG. 4

IN-PROCESS 'A'

(LEAD STYLE -12-T, -13, -14, -23, -24, -33, -34, -44, -37-T, -38, -39, -48, -49, -58, -59, -69)

FIG. 5

IN-PROCESS 'B'

(LEAD STYLE -12 & -37)  
(-S & -D ONLY)

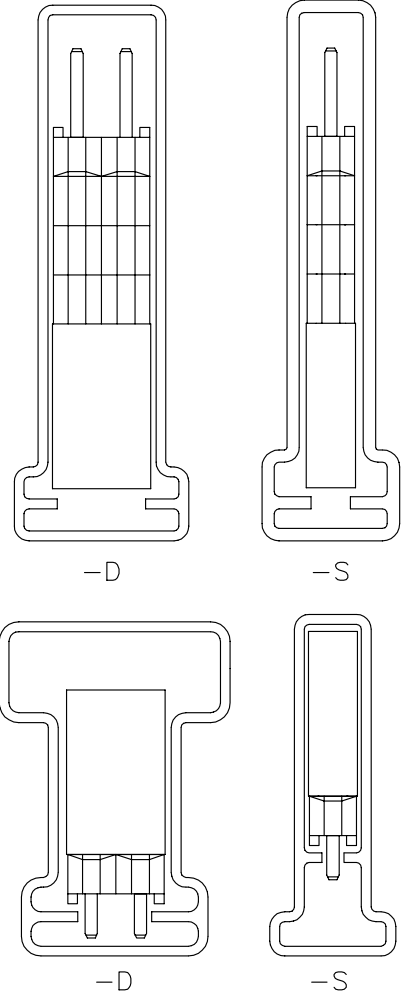

**PROPRIETARY NOTE**  
THIS DOCUMENT CONTAINS INFORMATION CONFIDENTIAL AND PROPRIETARY TO SAMTEC INC. AND SHALL NOT BE REPRODUCED OR TRANSFERRED TO OTHER DOCUMENTS OR DISCLOSED TO OTHERS OR USED FOR ANY PURPOSE OTHER THAN THAT FOR WHICH IT WAS OBTAINED WITHOUT THE EXPRESSED WRITTEN CONSENT OF SAMTEC INC.

**samtec**

MISC\MKT  
ESQ-ASM3

520 PARK EAST BLVD. NEW ALBANY, INDIANA 47150  
PHONE (812) 944-6733 P.O. BOX 1147  
CODE 55322

MADE BY: WHITTAKER 9-11-98

ESQ-1XX-XX-X-X-XXX-XX-X-XX  
SHEET 3 OF 3

PLOT SCALE 1=2