



Digital Compass Users Guide, OS1x00 & OS3x00

REVISION 1.7

© 2007 OceanServer Technology, Inc, 151 Martine St, Fall River, MA 02723 USA

www.ocean-server.com Sales@ocean-server.com

Table of Contents

Introduction to the Tiny Compass Family	3
OS Compass Design Features	5
Specifications	6
Electrical Connector and pin assignment.....	7
Cables & Jumpers.....	8
Communicating with the compass, RS-232 or USB.....	11
Compass Mounting Guidelines	14
Calibrating the Compass	15
Installing Windows Demo Utility	19
Summary to Configure the Compass.....	20
Configuring OS1500 and OS3500 for Depth.....	21



Introduction to the Tiny Compass Family

The OceanServer precision 3-Axis Tilt Compensated compass products use state of the art technology to provide outstanding performance and ease of use in a low cost design.

The OS1x00 & OS3x00 compasses use high precision Anisotropic Magnetoresitive magnetic 3 axis sensors from Honeywell to measure the earth's magnet field. The Z-axis measurement allows the compass to calculate azimuth when the compass is tilted at an angle. These sensors are solid state and can survive being dropped from the sky. To increase the resolution and accuracy of measurements the designs utilize state of the art 24 bit differential AD converters and advanced digital filtering to provide the highest accuracy the sensors can provide.

The tilt measurement provides the roll and pitch information for attitude. The attitude is used to mathematically gimbal the compass for true azimuth measurements when the device is not level. The tilt measurement is made with dual axis digital accelerometers from Memsec. These sensors measure the gravity vector in two axes's allowing an accurate calculation of roll and pitch angle. These solid-state accelerometers replace the older electrolytic liquid level sensors providing much greater accuracy as well the ability to withstand 50,000 G shocks.

The OS3x00 compass provides both a USB port and a full RS232 data connection for interfacing to embedded computer systems. The OS3x00 sensor size is a single sided circuit board 1.4 x 1.8 inches and consumes a 40 milliamps at 5V when operating. A 50 MIPS state of the art processor drives the device. The firmware provides built in calibration routines that can be run in the end system to calibrate the compass and zero the tilt sensors. The compass tilt stabilizes the azimuth readings by using the roll and pitch angles and trigonometry to create a level projection from the 3 axis magnetic sensors and generate the heading azimuth. The OS3500 model supports pressure measurement for depth reporting directly in the compass data stream.

The OS1x00 is one of the smallest compasses in the world supporting RS-232 signaling levels and full 3-axis tilt compensation. The OS1500 model supports pressure measurement for depth reporting directly in the compass data stream.

OCEANSERVER COMPASS MANUAL

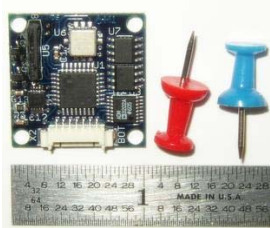

OS1000- 3-Axis Compass, 1" x 1" size with full RS-232 support

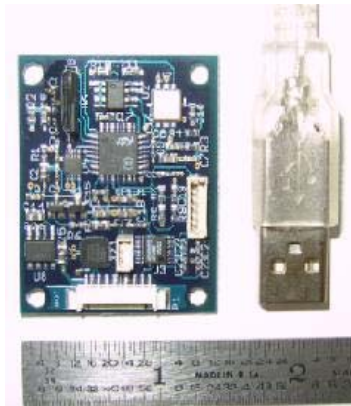

OS3000 – 3-Axis tilt compensated compass, 1.4" x 1.8" USB direct interface

Note: the OS1500 and 3500 versions support pressure measurement for depth

OS Compass Design Features

Magnetic Sensors:

Honeywell HMC1052 two-axis AMR sensor for X, Y plane sensing

Honeywell HMC1051Z z-axis AMR sensor

Accelerometer, tilt sensor:

Memsic MXS3334UL two-axis MEMS accelerometer

Microprocessor:

50 MIPS processor that supports IEEE floating point operations for accurate tilt compensation.

AD Conversion:

24 bit Sigma-Delta converters with differential inputs

RoHS Compliant Versions Available (April 07)

Specifications

Dimensions:

OS1000: 1" x 1" module

OS3000: 1.4" x 1.8" Module

Power Supply:

OS1x00: Voltage: 3.3V operation regulated, 3.8V – 18V unregulated,

Current: 25ma typical Power: @ 3.3V = 82.5 mW typical

OS3x00: Voltage: 5V regulated (USB), 3.3V – 5V (RS232)

Current: 40ma

Environmental:

Ambient Temperature: -20C to 70C

RH: 20% Max, non-condensing

Accuracy:

Heading accuracy: (undisturbed magnetic environment)

Level: 1 degree typical

0 to +/-30 tilt: 3 degrees typical

Roll & Pitch accuracy: 2 degree typical (0-60 degree range)

Sensor Output Rate:

The compass can send a NMEA like sentence as slow as 1 every 100 seconds to as fast as 20 per second. (0.01 Hz to 20 Hz).

Baud Rate:

300 Baud to 115200 Baud, 8 bits, 1 stop, no-parity

Electrical Connector and pin assignment

OS1000/OS1500: 7 pin, Molex 1.25mm connector (Molex: 51021-0700) – Available on www.Mouser.com along with pins and tools to make custom cables

Pin	Color	Signal	Description
1	White	P-in	Pressure Input from Transducer (MSP-340, 0.5 – 4.5V [1/2])
2	Black	GND	Ground
3	Red	Vin- Unreg	Unregulated input Voltage, 3.8V to 18V – Device uses constant current so lower voltage is lower power
4	Orange	3.3V	Regulated 3.3V input, only use one of pin 3 or 4
5	Black	GND	Ground – Use with RS232
6	Green	Tx	RS-232 Transmit (DB9-F pin: 2)
7	Blue	Rx	RS-232 Receive (DB9-F Pin: 3)

OS3000/OS3500: 10 pin, Molex 1.25mm connector (Molex: 51021-1000) – Available on www.Mouser.com along with pins and tools to make custom cables

Pin	Color	Signal	Description
1	Red	5V Power	Connect to USB Red or 5V power
2	Green	USB D+	USB Data + Signal, USB Green
3	White	USB D-	USB Data – Signal, USB White
4	Black	GND	USB Ground, USB Black
5	Blue	Rx	RS232 Receive, (DB9 pin: 2)
6	Black	GND	RS232 Return (DB9 Pin 5)
7	Green	Tx	RS232 Transmit (DB9 Pin: 3)
8	Black	GND	

9	White	Pressure	Input from pressure sensor (ex. MSP-340, 0.5-4.5V [1/2] Must use voltage divider before input as max input 2.5V
10	Orange	3.3V Power	Use pin 10 or pin 1. 3.3V only works for RS-232 operation

Cables & Jumpers

OceanServer offers a variety of cables, which come with the compass evaluation kits or can be ordered separately. A USB and Serial jumper are shipped with any OS3000 or OS3500 unit so users can select either interface.

Standard Cables:

19-00061-24, 24" OS1000/1500 Demo Kit Cable with Serial connection, Pressure and 9V battery power connection (picture below) Demo cable provides 9V battery connection. Cable Note: this cable is a quick way to get the compass running for evaluation. It is highly recommended that you operate the compass from 3.3V or 5V as any voltage higher than 3.3V wastes power and heats up the compass.

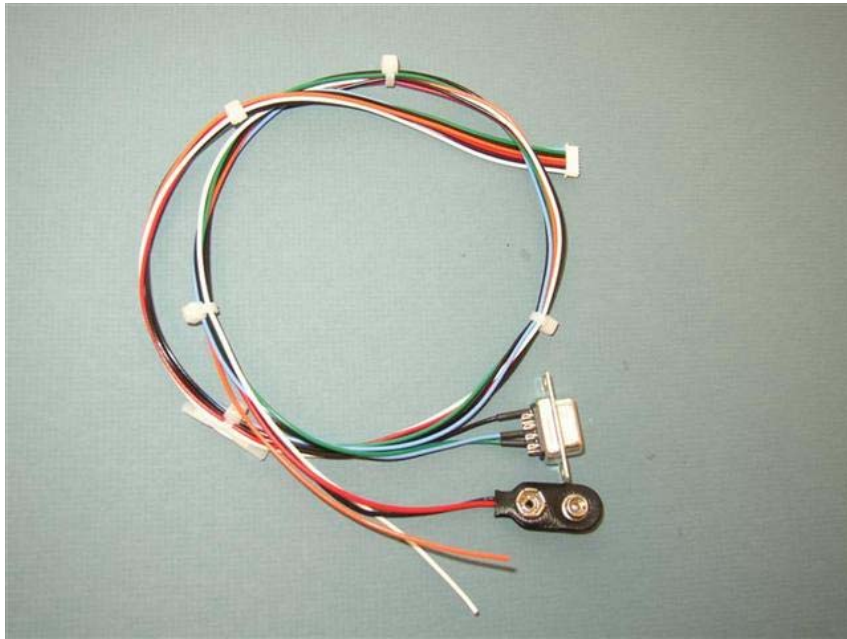

19-00062-24, 24" OS1000/1500 Series Pigtail Cable, 7 Pin connector, blunt cut (below)



19-00056-24, 24" OS3000/3500 Demo Kit Cable with USB and Pressure (below)



19-00063-24, 24" OS3000/3500 Series Pigtail Cable, 10 Pin connector, blunt cut (below)

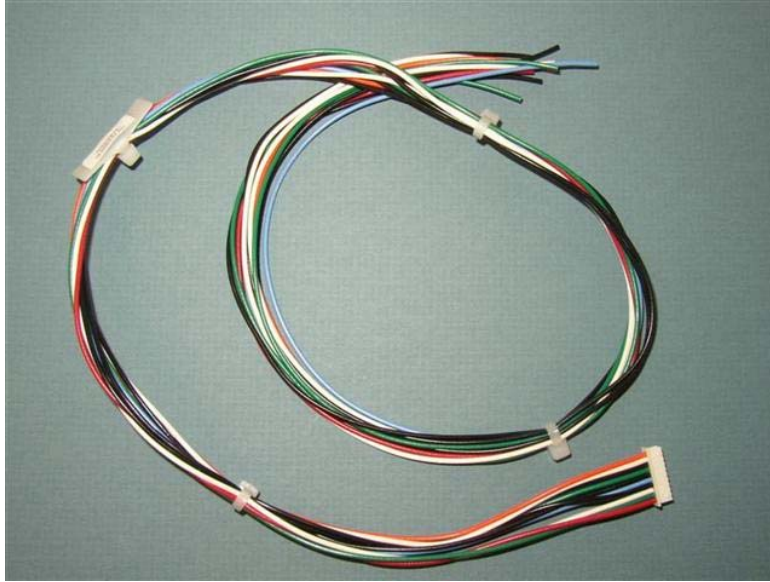

Jumpers (OS3000/3500)

Jumper ship with all board and kit orders. Note: you will be unable to do any programming/calibrating without the correct jumper installed.

19-00059-00, OS3000/3500 Serial Jumper (Blue)

19-00060-00, OS3000/3500 USB Jumper (White)

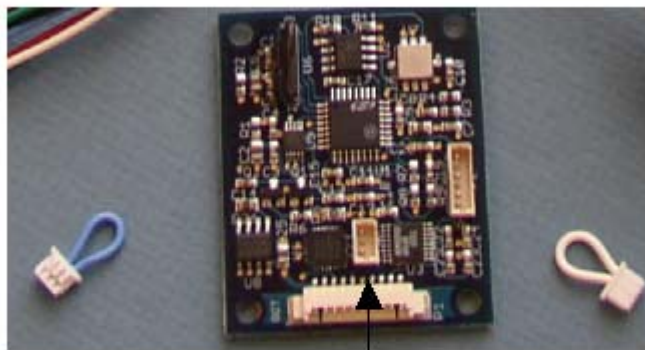

Jumper Location

Communicating with the compass, RS-232 or USB

The USB compass presents it's data to the system via a COMn: port by installing it's USB to Serial bridge software found on our web site. www.ocean-server.com/compass/. At this point all compass designs present themselves as serial port devices at a buad rate, 8 bits, 1 stop bit (ASYNCH).

Using a windows system open up a Hyperterm port to the compass device. The factory default baud is 9600, 8, 1, N.

```

COM4X96 - HyperTerminal
File Edit View Call Transfer Help
$C332.0P0.0R-0.7T17.0D0.0*61
$C332.0P0.1R-0.4T17.0D0.0*63
$C332.0P0.1R-0.4T17.0D0.0*63
R
Rate (-100-0-20)=10
Value and Enter, or Esc -2
$C333.7P0.0R0.0T17.0D0.0*4D
B
Baud (0-7)=3
Value and Enter, or Esc
$C333.7P0.0R0.0T17.0D0.0*4D
T
Level compass <space>
$C333.8P-0.1R0.0T17.0D0.0*6E
D
Decimation (20-2000)=300
Value and Enter, or Esc 400
$C334.8P-0.2R0.1T17.0D0.0*6B
Q
Declination=0
Value and Enter, or Esc -102
$C334.5P-5.6R6.3T17.0D0.0*63
$C324.6P0.0R0.0T17.0D0.0*4A
-
Connected 2:19:45 Auto detect 9600 8-N-1 SCROLL CAPS NUM Capture Print echo
    
```

The compass always displays it's output string when it's operating. It has the following format (screen shot prior to Firmware V3.61):

“\$C” NMEA style command name.

Hhh.h Heading in degrees, corrected for Declination if one is entered

Rrr.rr Roll angle, “R” precedes the roll angle in degrees

Ppp.p: Pitch angle, “P” precedes the pitch angle in degrees

Ttt.t: Temperature of the compass board

Dddd.dd: Depth in water in feet (available on OS1500 and OS3500 units)

*cc This is the end of line character, the cc is the HEX X-OR sum of the characters between the \$ and the *. This is the NMEA standard format.

Example: \$C328.3P28.4R-12.4T21.1D21.01*<checksum> <cr><lf>

- Compass heading: 328.3 degrees
- Pitch angle: 28.4 degrees
- Roll angle: -12.4 degrees
- Temp: 21.1 degrees
- Depth: 21.01 feet [This is only output on the OS1500, OS3500 versions]

Additional TTL Note: The OS1000 has a true RS232 interface. It should accept TTL input but you will need to clamp it on the output so you don't exceed the TTL input limits. There are some converters that can do this function or you can look at the following options:

<http://www.pololu.com/products/pololu/0126/>

<http://www.kevinro.com/cable.pdf>

Hyperterm Issues: OceanServer compasses will usually show up as an additional Hyperterm port when properly connected to a system. If the compass cannot be communicated/programmed check to confirm the Hyperterm port has the correct settings (baud is 9600, 8, 1, N). If the settings are correct it could be a Hyperterm system issue and you may want to download a different terminal program. One possible program is TeraTerm:

TeraTerm (Support Forum)

<http://www.neocom.ca/forum/viewtopic.php?t=436>

The install for version 4.51 and can be locate at

http://www.neocom.ca/freeware/TeraTerm/teraterm_utf8_451.exe

Important Programming Notes: Hit <Esc> key prior to a key command. Key commands should be pressed a few seconds after <Esc> key is released and are case sensitive. Some command changes require the compass to be power cycled for changes to take affect. Compasses with Firmware version 3.61 or greater have a slightly different output: the <Esc> key will output “CMD:” and pause the output waiting for (5 seconds) you to type a command key. Note “T” command is no longer an option with 3.61V (not necessary)

Key Command	Description of the command
<Esc> B	Set new baud rate, 0-7, change takes effect after power cycle. 0=1200,1=2400,2=4800,3=9600,4=19200,5=38400,6=57600,7=115200
<Esc> R	Set the compass output rate, -100 to +20. Rate is in samples per second and negative are seconds per sample. .i.e. 20=20 samples/second, -20=20 seconds per sample. A rate of 0 will stop output
<Esc> X	Fields to Display, bit mask of 5 bits (entered in decimal). 31=all active. Sum up the values, Azimuth=1, Pitch=2, Roll=4,Temp=8,depth=16.
<Esc> Q	Enter Declination angle to create offset for compass Azimuth. Value is 10x degrees. Example: -103=-10.3 degrees, 152=15.2 degrees.
<Esc> D	Decimation value. This is the input to the AD filter for compass readings. The lower the value the faster and nosier the magnetic readings will be. A good starting place is 400 and test from there. Tuning this value can eliminate electrical noise induced form your platform. You should calibrate the compass after changing the “D” value.
<Esc> C	Calibrate the compass in the platform. Level the platform and prepare to rotate it slowly 1.1 complete times. You should keep the platform level while you rotate.
<Esc> Z	Rotate your platform 90 degrees on it’s side. This will place the Z axis in the same “earths” magnetic field the “C” calibration saw for the x,y sensors. Perform once complete and slow rotation.
<Esc> T	Tilt Zero .. When the compass and platform are perfectly level you can use the T command to null the level point in the compass. The true compass should be close to level when mounted in your device.

<Esc> P	Zero the depth pressure sensor. This would be at the surface for an underwater device. It set's zero based on the current ATM pressure.
<Esc> M	Sets the maximum pressure for the MSP-340 pressure sensor, example 100 PSI
<Esc> V	Displays the firmware version installed on this device

Compass Mounting Guidelines

In general you should mount the compass in a location in your vehicle or device that has the least disruption to the earth's magnetic field.

- 1) Mount away from permanent magnets such as motors. The fields fall off as $1/d^2$ so doubling the distance reduces the field strength by $1/4$.
- 2) Mount the compass away from moving magnetic fields such as wires carrying current, moving magnets, generators, etc.
- 3) Mount the compass as far as possible from batteries and ferrous materials such as soft iron.
- 4) Mount the compass component side up, level or true to platform level with the arrow pointing forwarded.
- 5) Mount the compass in a mechanically stable location so this it moves with the vehicle or device but doesn't vibrate.
- 6) Metals such as aluminum, brass or copper do not block magnetic fields but currents can still flow through them that could create unwanted local magnetic fields. Metals such as iron and steel will distort the magnetic field. OceanServer ships compasses with plastic standoff but users should insure that the compass has sufficient distance from ferrous objects that could bend the earth's magnetic field and disrupt compass accuracy.

Aircraft Note: Most electronic compasses use accelerometers to measure tilt (including OceanServer compasses). The tilt angles are determined by measuring the earth's static gravitational vector. Since, dynamic and static acceleration are indistinguishable when used in aircrafts with high acceleration and banking turns, the dynamic acceleration will introduce an error in both roll and pitch angle reported by the compass as well as heading errors. Only level headings will be accurate when aboard a plane and vibration needs to be considered. Strong vibration also applies acceleration to the compass and can cause errors if the amplitude of the acceleration is significant as compared to the earth's 1G acceleration due to gravity

OS1x00 Mounting hole locations, note you need to use small outline nylon screws for mounting (Included in evaluation kit).

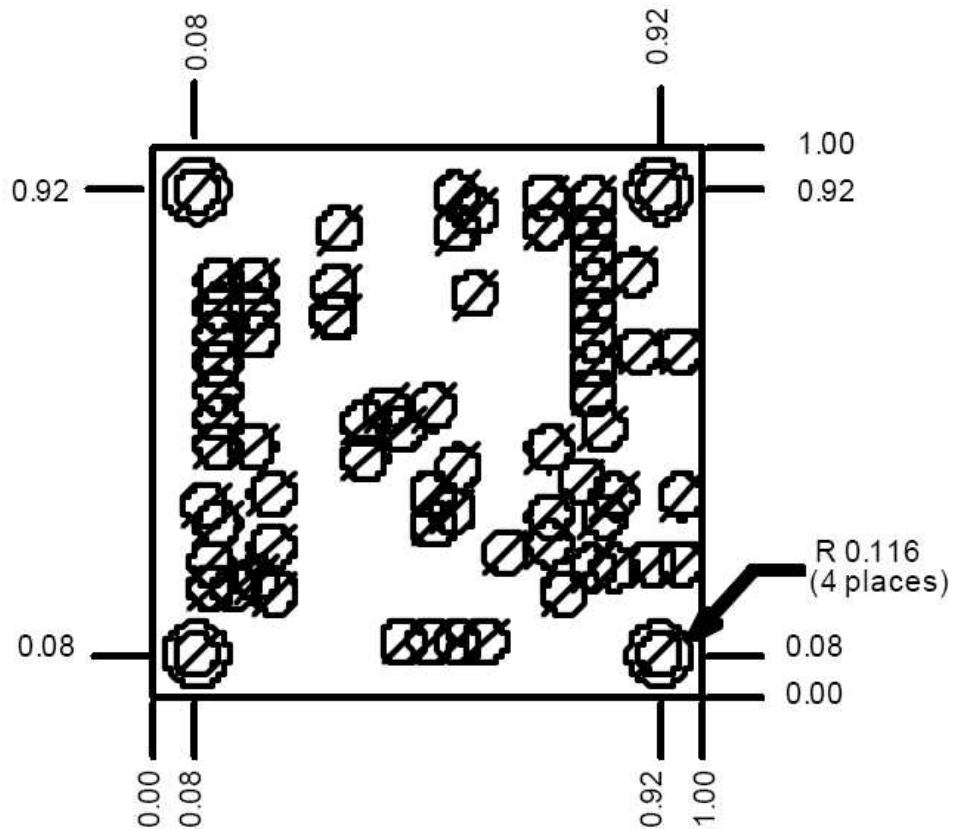

Calibrating the Compass

Compasses operate by measuring the earth's magnetic field and locating magnetic north. When mounted in real platforms or devices there are other local magnetic fields or materials that disrupt or offset the earth's magnetic field. Sources to be aware of are Ferrous metal, electric currents and permanent magnets in electric motors. There are two sources of magnetic field distortion: "Soft-iron" and "Hard-iron". "Soft-iron" effects are caused by un-magnetized ferrous materials in the area of the compass. "Hard-Iron" effects are caused by magnetized ferrous materials near the compass. "Hard-Iron" can be cancelled out by going through the rotational calibration (described below). "Soft-iron" effects should be addressed during the design in phase and compasses should be located away from such items to minimize impact to the sensor.

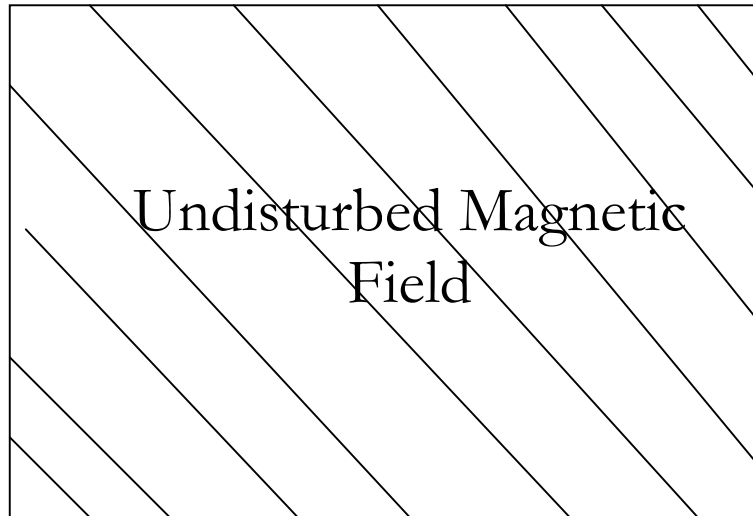

Compass Placement

Ferrous Material in Tail
Plus an Electric Motor
Creating Magnetic
Field Disturbance
Not an Ideal Place for
Compass Placement

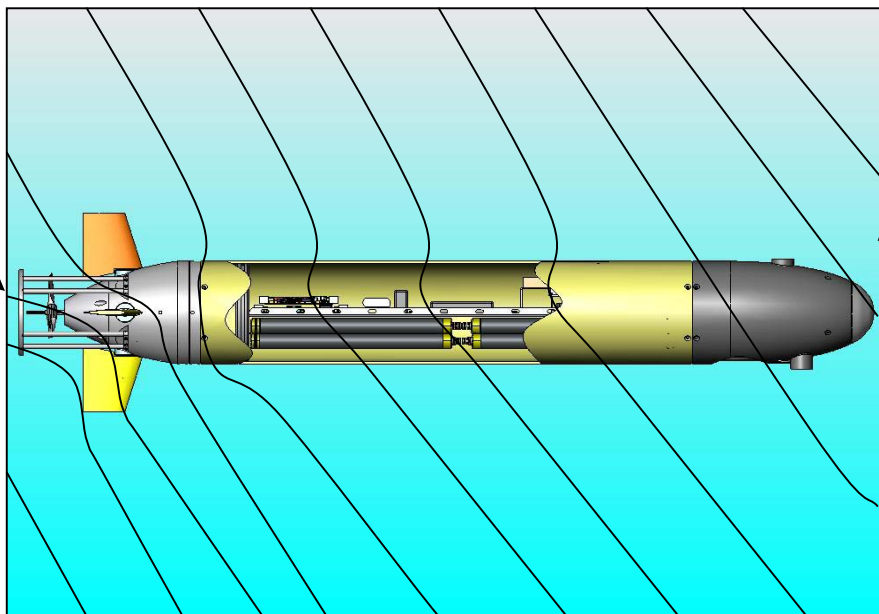

Non-Ferrous Bow
Least Magnetic
Field Disturbance
Best Place for
Compass
Placement

Step 1: Select appropriate location and install OceanServer Compass in device

IMPORTANT NOTE: Compasses with Firmware Version 2.98 – 3.60 require users to hit the < Esc > key prior to each programming/calibration step. This has been added to prevent accidental programming. Compasses with Firmware version 3.61 or greater <Esc> will output CMD: and pause the output waiting for you to type a command key. Note “I” command is no longer needed with 3.61V (no longer necessary)

Step 2: Open a Hyperterm window to take two separate measurements (X-Y together, and Z) for calibration

Step 3 (Calibrating X, Y): Press <Esc> key, next enter uppercase “C” key and slowly rotate the device at least one complete rotation. Note: the device should be kept as level as possible to calibrate the X, Y magnetic sensing elements. Terminate sequence with SPACE bar key after you have slowly rotated the device more than 1 full rotation over 30 plus seconds. **Note:** X an Y calibration is completed when characters stop appearing and you see “.....”

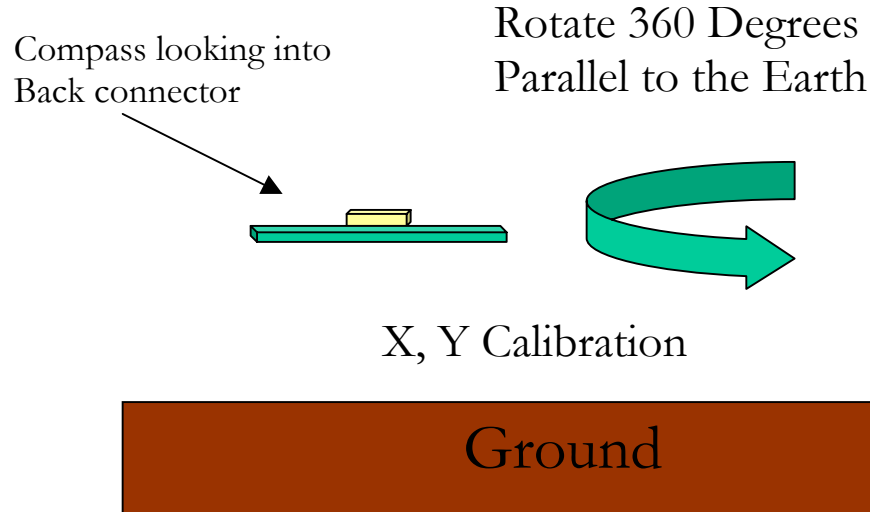

Step 4 (Z Calibration): Rotate device (90 degrees) so it is turned on its side

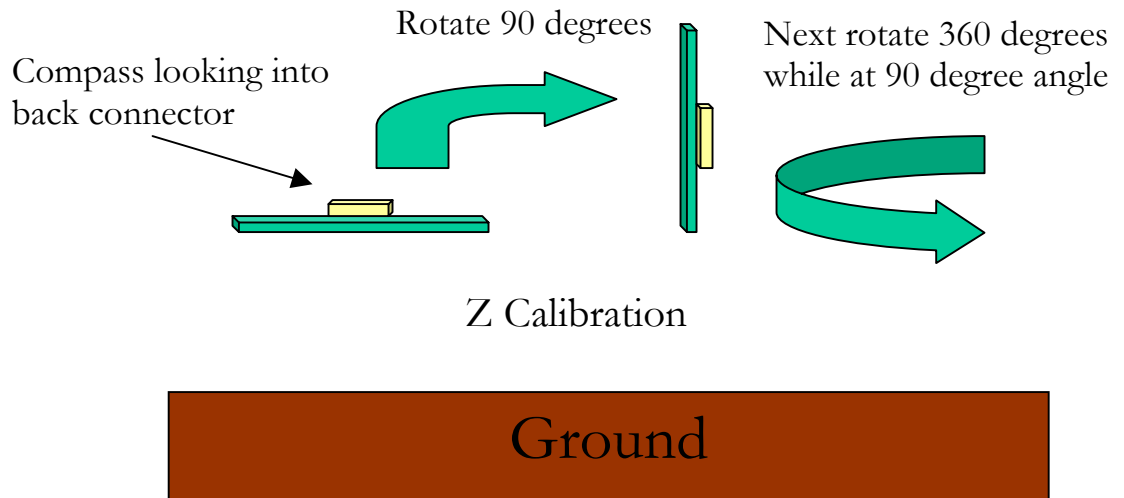

Step 5 Press <Esc> key, Enter uppercase “ Z ” key and slowly rotate the device 360 degrees (at least one complete rotation). Terminate sequence by hitting SPACE bar. Important Note: The “Z” command should be done in the same location to calibrate and align the Z axis sensor to the X, Y. This is important for tilt compensation. Errors in heading, when the device is tilted, will result from no Z axis calibration.

The compass calibration routines compensate for hard iron effects in the system where the compass is mounted. It is important to calibrate the compass when it is mounted level in the user device or platform to get the most accurate readings. The “C” routine compensates the X,Y sensors for level operation. It adjusts the offsets and gains to provide the best results possible given the disruptions to the field. This calibration requires that you keep the platform and compass level while rotating the system. The Z axis calibration is important to improve the accuracy of the compass readings when the platform is tilted and it counts on the three orthogonal sensors providing the same results to the same magnetic field. If you can’t roll your platform 90 and do the “Z” calibration the compass will have less accuracy when tilted.

The calibration routines do not compensate for soft iron effects. Soft iron, batteries, wires with moving currents and other high permeability materials in the near field cause these. These are generally far weaker than hard iron effect. Choosing a good mounting location with distance from soft iron structures is the best solution.

```

$C206.3P1.3R6.9T16.9D0.0*4B
$C282.4P-0.8R0.0T16.9D0.0*68
C
Calibrate X,Y <space> when done.xYxyxYxYxYxYxY.xYxYxYxYxYxYxY.xYyYyYyYyY.yYxY
XXXXX.X.....Y...XX.$C231.5P90.0R-13.2T17.2D0.96*55
  $C250.7P90.0R-13.1T17.2D1.10*5C
$C259.0P90.0R-12.4T17.2D1.18*5E
$C265.2P90.0R-10.8T17.2D1.23*55
$C243.2P90.0R-5.9T17.2D1.24*63
Z
Calibrate Z <space> when done.zzzzzzzzzzzzzzz.zzzz.zzzzzzzzz.zzzzzzz.zzzzzz.zzz.
zz.zzzz....._

```

Screen Display: Hyperterm output showing the “C” X, Y calibration – User terminates with a SPACE bar when you have rotated the device more than 1 full rotation over 30+ seconds.

Platform is tuned on it’s side 90 degrees, the “Z” commands is entered and rotated another full turn, space to end.

Important Note: X, Y and Z calibration is completed when characters stop appearing and you see “.....”

Installing Windows Demo Utility

The windows demo utility is located on the web at www.ocean-server.com/compass/

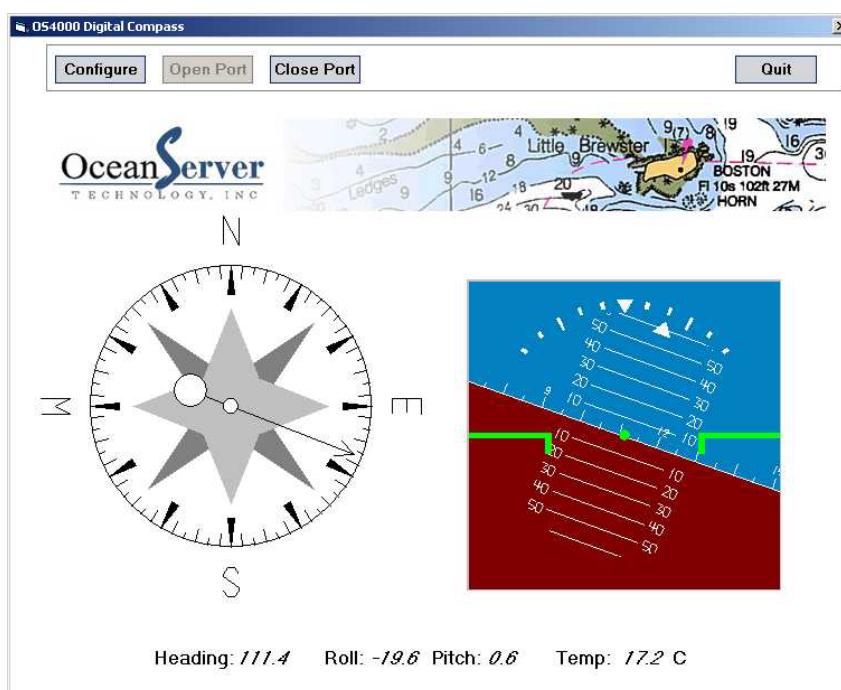

Windows Demo Utility – Use Configure to set up the port speeds. You are still required to use Hyper term to configure the compass settings.





USB Drivers for the OceanServer OS3x00 family of compasses

www.silabs.com > support > downloads > CP21xx drivers

The OS3x00 compass family uses the CP2101 USB to Serial bridge chip. Silabs supports drivers for most major operating systems. Our demo program runs on Windows only but on all other operating systems you can open a terminal program to the virtual serial port and talk/listen to the compass with it's NMEA strings.

These USB drivers allow the OS3x00 compass operating in USB mode to communicate to Windows, Linux or MAC OS by creating a virtual serial port. The base controller is the SILABS CP210x USB to Serial bridge. You still need to open the Hyperterm or application with a Baud rate that matches the rate set on the compass with the “B” command.

Index of /compass

<u>Name</u>	<u>Last modified</u>	<u>Size</u>	<u>Description</u>
 Parent Directory	12-Feb-2007 12:51	-	
 CompassDemoInstallV2..>	09-Feb-2007 12:55	3.0M	
 CompassDemoInstallV2..>	09-Feb-2007 12:56	2.9M	
 USBdrivers/	08-Nov-2006 06:54	-	

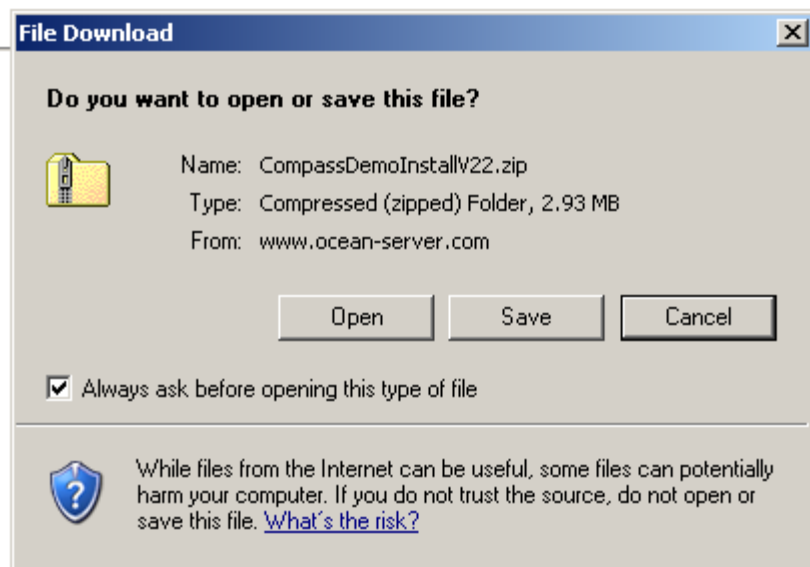

Download the Compass-install.zip file and open it. This installer will put the compass demo program on your system.

Summary to Configure the Compass

- 1) Mount the compass in the best location away from ferrous materials

- 2) Configure the compass firmware (hit <Esc> key prior to any command key)
 - a. Hyperterm, 9600,8,1,N to the device.
 - b. “B” Set baud rate
 - c. “C” calibrate X,Y (rotate 360+ in 30+seconds, level X,Y)
 - d. “Z” Calibrate X (tip platform on side, rotate 360+)
 - e. “Q” Set the Declination value if you want “True magnetic output” – This will offset for the delta between magnetic north and true north.
 - f. “R” set the output rate for your application

Configuring OS1500 and OS3500 for Depth

OS1500 connection with MSI pressure transducer, voltage divider is required as compass input Is 2.5V maximum.

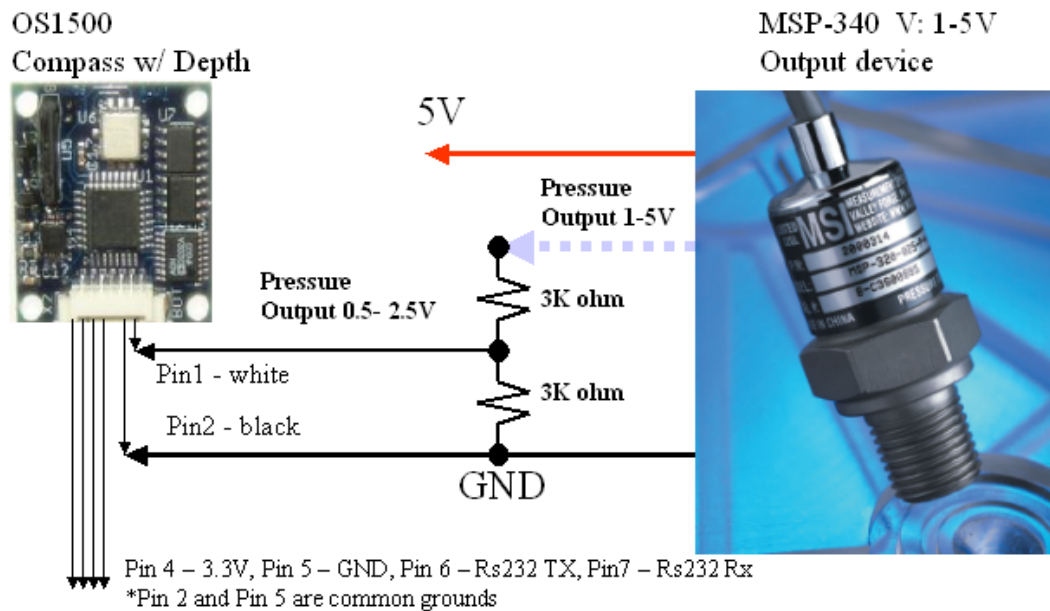

OS1500 commands: <esc>M nnnn <enter> enter max pressure range for sensor PSI
<esc>P<space> set zero depth, pressure output via 24bit AD, resolution in 0.01 feet
* Note: Depth assumes fresh water, no internal density correction

Important Note: the OS3500 has a different pin out compared to the OS1500. Please reference OS3500 for proper connection.

Customer Support

Send technical questions to: support@ocean-server.com

Or call us at 508-678-0550 during normal business hours.

Copyright © 2007 by OceanServer Technology, Inc. All Rights Reserved.