

## Ares Series

PCB Mounted Pressure Transducers

Amplified Output

Differential and Gage Pressure

Temperature Compensated

- HVAC
- Medical Equipment
- Environmental Controls
- Portable Monitors
- Volume OEM Applications



### FEATURES

- Very Low Pressure Ranges
- Small Size
- PCB Mountable
- Solder Reflow Capability
- Barbed Pressure Ports
- Dry/Dry Differential Transducer

### STANDARD RANGES

Ares Model Number	Operating Pressure	Accuracy %FSO(1)
GA100-005WD	0 to 5" H <sub>2</sub> O	0.25%
GA100-010WD	0 to 10" H <sub>2</sub> O	0.5%
GA100-015WD	0 to 15" H <sub>2</sub> O	0.5%
GA100-001PD	0 to 1 PSI	0.75%
GA200-005WD	0 to 5" H <sub>2</sub> O	0.25%
GA200-010WD	0 to 10" H <sub>2</sub> O	0.5%
GA200-015WD	0 to 15" H <sub>2</sub> O	0.5%
GA200-001PD	0 to 1 PSI	0.75%

#### Note

1. Includes effects of non-linearity, hysteresis and repeatability.

### DESCRIPTION

The Ares Series is a small, low cost pressure transducer, which is able to measure pressures as low as 0 to 5, 0 to 10, 0 to 15 inches of water, and 0 to 1 psi. The ranges combined with the small physical size make the device ideally suited for applications such as HVAC, medical equipment and flow monitoring.

The GA100 series has a 4V span from 0.50V to 4.50V and the GA200 series has a 3.75V span from 0.25V to 4.00V.

The plastic housing design for the Ares Series makes the device very user friendly. The housing is designed to be printed circuit board mountable, requiring no additional hardware. Built into the housing are self locking pins which insure a secure fit between the housing and the PCB. The pressure ports are 3/16" barbed ports which mate with industry standard 1/8" or 3/16" ID tubing. These ports are mounted 90° to the printed circuit board to allow other boards to be located above the sensor.

Providing both error correction and signal amplification, the electronic module's ASIC uses digital compensation while maintaining an analog signal path, a unique design among piezoresistive sensor products. The technique provides the high level of error correction found in microprocessor-based circuits but with a typical bandwidth of >1 kHz generally found only in analog circuits. The result is a pressure sensor that offers the ultimate in low-cost and high accuracy, while preserving the fast response and smooth output inherent to silicon sensors.

The ASIC is a mixed signal CMOS sensor interface that uses differential switched capacitor architecture, and was specifically designed to compensate for the errors associated with piezoresistive silicon sensors. This ASIC design reduces the external parts requirement for calibration, allowing a smaller overall PCB size while maintaining outstanding performance characteristics. Due to its small size, barbed pressure ports, and solder re-flow capability, the Ares pressure transducer is ideally suited for a wide range of applications.

# PC Board Mountable Pressure Sensor

## Ares Series

### PERFORMANCE SPECIFICATIONS

Specifications for Port A pressure input

Supply Voltage: 5V

Ambient Temperature: 25°C (Unless otherwise specified)

PARAMETERS	GA100 SERIES			GA200 SERIES			UNITS	NOTES
	MIN	TYP	MAX	MIN	TYP	MAX		
Zero Offset	0.450	0.500	0.550	0.200	0.250	0.300	V	
Span	3.975	4.000	4.025	3.725	3.750	3.775	V	1
Full Scale Output	4.425	4.500	4.575	3.925	4.000	4.075	V	

PARAMETERS	MIN	TYP	MAX	UNITS	NOTES
Input voltage range	4.75	5.00	5.25	V	2
Proof Pressure to any port			5	psi	
Burst Pressure	10			psi	
Common Mode Pressure			10	psi	
Long Term	-0.5		+0.5	%/FSO/year	
Output Impedance			5	$\Omega$	
Temperature Error - Span			1.5	%/FSO	3
Temperature Error - Zero			1.5	%/FSO	3
Media	Non-ionic, non-corrosive (clean, dry gases)				
Compensated Temperature	0° to 60°C				
Operating Temperature	-25° to 80°C				
Reflow Temperature	240°C (5 sec max)				

#### Notes

- The span is defined as the algebraic difference between the electrical output at full scale pressure voltage and the electrical output at zero pressure.
- Output is ratiometric to input voltage variation.
- Over compensated temperature range.
- Shock: 50g, 11msec, 1/2 sine per Mil Std 202F, Method 213B, Condition A.
- Vibration: 10g sinusoidal peak to peak per Mil Std 810C.
- Humidity: 95% non-condensing.
- For differential applications, the input pressure to Port A must be higher than Port B.
- Consult factory for custom output options.

### DIMENSIONS

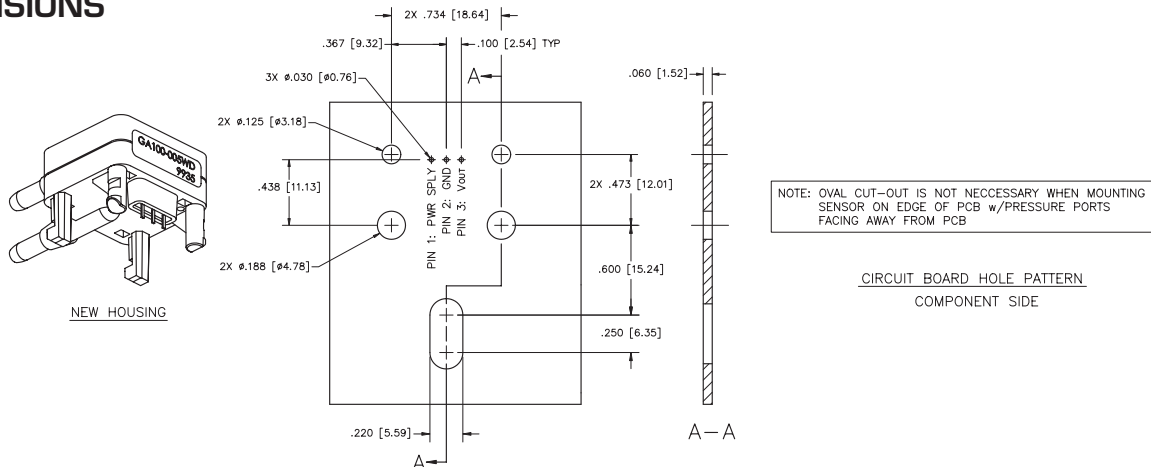

### CONNECTIONS

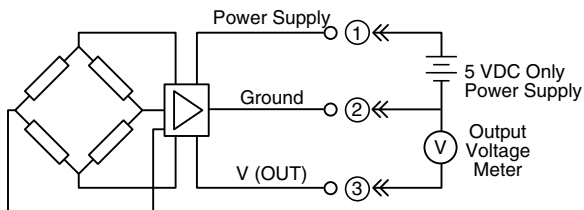

### ORDERING INFORMATION

**GA 100 - 005WD**  
 Pressure Range (005WD=5" H<sub>2</sub>O, 010WD=10" H<sub>2</sub>O, 015WD=15" H<sub>2</sub>O, 001PD=1 PSI)  
 Output Configuration (100=0.5 to 4.5V, 200=0.250 to 4V)