

NTSC/PAL Digital Video Encoder

Features

- Six DACs providing simultaneous composite, S-video, and RGB or Component YUV outputs
- Programmable DAC output currents for low impedance (37.5 Ω) and high impedance (150 Ω) loads
- Multi-standard support for NTSC-M, NTSC-JAPAN, PAL (B, D, G, H, I, M, N, Combination N)
- ITU R.BT656 input mode supporting EAV/SAV codes and CCIR601 Master/Slave input modes
- Programmable HSYNC and VSYNC timing
- Multistandard Teletext (Europe, NABTS, WST) support
- VBI encoding support
- Wide-Screen Signaling (WSS) support, EIA-J CPX1204
- NTSC closed caption encoder with interrupt
- CS4955 supports Macrovision copy protection Version 7
- Host interface configurable for parallel or I²C compatible operation
- On-chip voltage reference generator
- +3.3 V or +5 V operation, CMOS, low-power modes, three-state DACs

Description

The CS4954/5 provides full conversion from digital video formats YCbCr or YUV into NTSC and PAL Composite, Y/C (S-video) and RGB, or YUV analog video. Input formats can be 27 MHz 8-bit YUV, 8-bit YCbCr, or ITU R.BT656 with support for EAV/SAV codes. Video output can be formatted to be compatible with NTSC-M, NTSC-J, PAL-B,D,G,H,I,M,N, and Combination N systems. Closed Caption is supported in NTSC. Teletext is supported for NTSC and PAL.

Six 10-bit DACs provide two channels for an S-Video output port, one or two composite video outputs, and three RGB or YUV outputs. Two-times oversampling reduces the output filter requirements and guarantees no DAC-related modulation components within the specified bandwidth of any of the supported video standards.

Parallel or high-speed I²C compatible control interfaces are provided for flexibility in system design. The parallel interface doubles as a general purpose I/O port when the CS4954/5 is in I²C mode to help conserve valuable board area.

The CS4954 and CS4955 are available in a 48-pin TQFP in Commercial grade (-10 to 85° C). The CDB4954/55 Customer Demonstration board is also available for device evaluation and implementation suggestions. Please refer to ["Ordering Information" on page 2.](#)

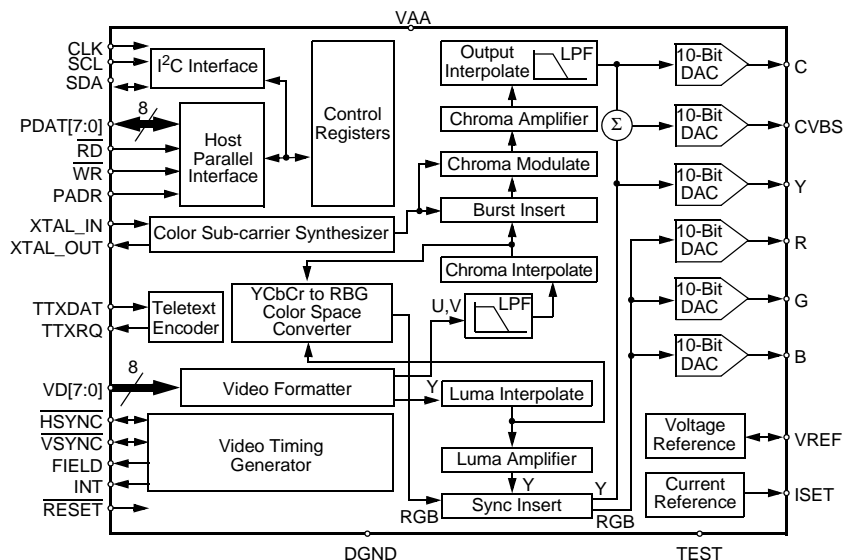

ORDERING INFORMATION

Product	Description	Package	Pb-Free	Grade	Temp Range	Container	Order#
CS4954	NTSC/PAL Digital Video Encoder	48-TQFP	Yes	Commercial	-10° to +85°C	Rail	CS4954-CQZ
CS4955							CS4955-CQZ
CDB4954/55	CS4954/55 Evaluation Board		No	-	-	-	CDB4954A/55A

TABLE OF CONTENTS

1. CHARACTERISTICS AND SPECIFICATIONS	6
AC & DC PARAMETRIC SPECIFICATIONS	6
RECOMMENDED Operating Conditions	6
THERMAL CHARACTERISTICS	6
DC CHARACTERISTICS	6
AC CHARACTERISTICS	8
TIMING CHARACTERISTICS	9
2. ADDITIONAL CS4954/5 FEATURES	11
3. CS4954 INTRODUCTION	11
4. FUNCTIONAL DESCRIPTION	11
4.1 Video Timing Generator	11
4.2 Video Input Formatter	12
4.3 Color Subcarrier Synthesizer	12
4.4 Chroma Path	12
4.5 Luma Path	13
4.6 RGB Path and Component YUV Path	13
4.7 Digital to Analog Converters	13
4.8 Voltage Reference	14
4.9 Current Reference	14
4.10 Host Interface	14
4.11 Closed Caption Services	14
4.12 Teletext Services	15
4.13 Wide-Screen Signaling Support and CGMS	15
4.14 VBI Encoding	15
4.15 Control Registers	15
4.16 Testability	15
5. OPERATIONAL DESCRIPTION	15
5.1 Reset Hierarchy	15
5.2 Video Timing	16
5.2.1 Slave Mode Input Interface	16
5.2.2 Master Mode Input Interface	16
5.2.3 Vertical Timing	17
5.2.4 Horizontal Timing	17
5.2.5 NTSC Interlaced	17
5.2.6 PAL Interlaced	17
5.2.7 Progressive Scan	18
5.2.8 NTSC Progressive Scan	18
5.2.9 PAL Progressive Scan	19
5.3 ITU-R.BT656	19
5.4 Digital Video Input Modes	21
5.5 Multi-standard Output Format Modes	21
5.6 Subcarrier Generation	22
5.7 Subcarrier Compensation	22
5.8 Closed Caption Insertion	23
5.9 Programmable H-sync and V-sync	23
5.10 Wide Screen Signaling (WSS) and CGMS	24
5.11 Teletext Support	24
5.12 Color Bar Generator	26
5.13 VBI encoding	26
5.14 Super White/Super Black support	27
5.15 Interrupts	27
5.16 General Purpose I/O Port	27
6. FILTER RESPONSES	28
7. ANALOG	31
7.1 Analog Timing	31
7.2 VREF	31
7.3 ISET	31
7.4 DACs	31
7.4.1 Luminance DAC	31
7.4.2 Chrominance DAC	31
7.4.3 CVBS DAC	32
7.4.4 Red DAC	32

7.4.5	Green DAC	32
7.4.6	Blue DAC	32
8.	PROGRAMMING	33
8.1	Host Control Interface	33
8.1.1	I ² C Interface	33
8.1.2	8-bit Parallel Interface	34
8.2	Register Description	35
8.2.1	Control Registers	35
9.	BOARD DESIGN AND LAYOUT CONSIDERATIONS	51
9.1	Power and Ground Planes	51
9.2	Power Supply Decoupling	51
9.3	Digital Interconnect	51
9.4	Analog Interconnect	51
9.5	Analog Output Protection	52
9.6	ESD Protection	52
9.7	External DAC Output Filter	52
10.	PIN DESCRIPTION	54
11.	PACKAGE DRAWING	56
12.	REVISION HISTORY	57

LIST OF FIGURES

Figure 1.	Video Pixel Data and Control Port Timing	8
Figure 2.	I ² C Host Port Timing	9
Figure 3.	Reset Timing.....	10
Figure 4.	ITU R.BT601 Input Slave Mode Horizontal Timing	16
Figure 5.	ITU R.BT601 Input Master Mode Horizontal Timing	16
Figure 6.	Vertical Timing	18
Figure 7.	NTSC Video Interlaced Timing	19
Figure 8.	PAL Video Interlaced Timing	20
Figure 9.	NTSC Video Non-Interlaced Progressive Scan Timing	21
Figure 11.	CCIR656 Input Mode Timing	21
Figure 10.	PAL Video Non-Interlaced Progressive Scan Timing	22
Figure 12.	Teletext Timing (Pulsation Mode)	25
Figure 13.	Teletext Timing (Window Mode)	25
Figure 14.	1.3 Mhz Chrominance low-pass filter transfer characteristic	28
Figure 15.	1.3 Mhz Chrominance low-pass filter transfer characteristic (passband)	28
Figure 16.	650 kHz Chrominance low-pass filter transfer characteristic	28
Figure 17.	650 kHz Chrominance low-pass filter transfer characteristic (passband)	28
Figure 18.	Chrominance output interpolation filter transfer characteristic (passband).....	29
Figure 19.	Luminance interpolation filter transfer characteristic	29
Figure 20.	Luminance interpolation filter transfer characteristic (passband)	29
Figure 21.	Chrominance interpolation filter transfer characteristic for RGB datapath.....	29
Figure 22.	Chroma Interpolator for RGB Datapath when rgb_bw=1 (Reduced Bandwidth)	30
Figure 23.	Chroma Interpolator for RGB Datapath when rgb_bw=1 (Reduced Bandwidth)	30
Figure 24.	Chroma Interpolator for RGB Datapath when rgb_bw=0 -3 dB	30
Figure 25.	Chroma Interpolator for RGB Datapath when rgb_bw=0 (Full Scale).....	30
Figure 26.	I ² C Protocol	33
Figure 27.	8-bit Parallel Host Port Timing: Read-Write/Write-Read Cycle.....	34
Figure 28.	8-bit Parallel Host Port Timing: Address Read Cycle	34
Figure 29.	8-bit Parallel Host Port Timing: Address Write Cycle	35
Figure 30.	External Low Pass Filter	52
Figure 31.	Typical Connection Diagram.....	53

1. CHARACTERISTICS AND SPECIFICATIONS

ABSOLUTE MAXIMUM RATINGS

AC & DC PARAMETRIC SPECIFICATIONS (AGND,DGND = 0 V, all voltages with respect to 0 V)

Parameter	Symbol	Min	Max	Units
Power Supply	VAA/VDD	-0.3	6.0	V
Input Current Per Pin (Except Supply Pins)		-10	10	mA
Output Current Per Pin (Except Supply Pins)		-50	+50	mA
Analog Input Voltage		-0.3	VAA + 0.3	V
Digital Input Voltage		-0.3	VDD + 0.3	V
Ambient Temperature Power Applied		-55	+ 125	°C
Storage Temperature		-65	+ 150	°C

WARNING: Operating beyond these limits can result in permanent damage to the device. Normal operation is not guaranteed at these extremes.

RECOMMENDED Operating Conditions (AGND,DGND = 0 V, all voltages with respect to 0 V.)

Parameter	Symbol	Min	Typ	Max	Units
Power Supplies: Digital Analog	VAA/VDD	3.15 4.75	3.3 5.0	3.45 5.25	V
Operating Ambient Temperature	TA	0	+ 25	+ 70	°C

Note: Operation outside the ranges is not recommended.

THERMAL CHARACTERISTICS

Parameters	Symbol	Min	Typ	Max	Units
Allowable Junction Temperature		-	-	135	°C
Junction to Ambient Thermal Impedance		-	-	-	
(Four-layer PCB) TQFP	θ_{JA-TM}	-	45	-	°C/W
(Two-layer PCB) TQFP	θ_{JA-TS}	-	65	-	

DC CHARACTERISTICS (T_A = 25° C; VAA, VDD = 5 V; GNDA, GNDD = 0 V.)

Parameter	Symbol	Min	Typ	Max	Units
Digital Inputs					
High level Input Voltage V [7:0], PDAT [7:0], Hsync/Vsync/CLKIN	VIH	2.2	-	VDD+0.3	V
High Level Input Voltage I ² C	VIH	0.7 VDD	-	-	V
Low level Input Voltage All Inputs	-	-0.3	-	0.8	V
Input Leakage Current	-	-10	-	+10	μA
Digital Outputs					
High Level Output Voltage I _o = -4 mA	VOH	2.4	-	VDD	V
Low level Output Voltage I _o = 4 mA	VOL	-	-	0.4	V
Low Level Output Voltage SDA pin only, I _o = 6mA	VOL	-	-	0.4	V
Output Leakage Current High-Z Digital Outputs	-	-10	-	+ 10	μA

Parameter	Symbol	Min	Typ	Max	Units
Analog Outputs					
Full Scale Output Current CVBS/Y/C/R/G/B (Notes 1, 2, 3)	IO	32.9	34.7	36.5	mA
Full Scale Output Current CVBS/Y/C/R/G/B (Notes 1, 2, 4)	IO	8.22	8.68	9.13	mA
LSB Current CVBS/Y/C/R/G/B (Notes 1, 2, 3)	IB	32.2	33.9	35.7	μA
LSB Current CVBS/Y/C/R/G/B (Notes 1, 2, 4)	IB	8.04	8.48	8.92	μA
DAC-to-DAC Matching (Note 1)	MAT	-	2	4	%
Output Compliance (Note 1)	VOC	0	-	+ 1.4	V
Output Impedance (Note 1)	ROUT	-	15	-	kΩ
Output Capacitance (Note 1)	COUT	-	-	30	pF
DAC Output Delay (Note 1)	ODEL	-	4	12	ns
DAC Rise/Fall Time (Note 1, 5)	TRF	-	2.5	5	ns
Voltage Reference					
Reference Voltage Output	VOV	1.170	1.232	1.294	V
Reference Input Current (Note 1)	UVC	-	-	10	uA
Power Supply					
Supply Voltage	VAA, VDD	3.15 4.75	3.3 5.0	3.45 5.25	V
Digital Supply Current	IAA1	-	70	150	mA
Analog Supply Low-Z (Note 6)	IAA2	-	100	150	mA
Analog Supply High-Z (Note 7)	IAA3	-	60	100	mA
Power Supply Rejection Ratio	PSRR		0.02	0.05	V / V
Static Performance					
DAC Resolution (Note 1)		-	-	10	Bits
Differential Non-Linearity (Note 1)	DNL	-1	± 0.5	+ 1	LSB
Integral Non-Linearity (Note 1)	INL	- 2	± 1	+ 2	LSB
Dynamic Performance					
Differential Gain (Note 1)	DG	-	2	5	%
Differential Phase (Note 1)	DP	-	± 0.5	± 2	°
Hue Accuracy (Note 1)	HA	-	-	2	°
Signal to Noise Ratio	SNR	70	-	-	dB
Saturation Accuracy (Note 1)	SAT	-	1	2	%

- Notes:
1. Values are by characterization only
 2. Output current levels with ISET = 4 kΩ , VREF = 1.232 V.
 3. DACs are set to low impedance mode
 4. DACs are set to high impedance mode
 5. Times for black-to-white-level and white-to-black-level transitions.
 6. Low-Z, 3 dacs on
 7. High-Z, 6 dacs on

AC CHARACTERISTICS

Parameter	Symbol	Min	Typ	Max	Units
Pixel Input and Control Port (Figure 1)					
Clock Pulse High Time	T _{ch}	14.82	18.52	22.58	ns
Clock Pulse Low Time	T _{cl}	14.82	18.52	22.58	ns
Clock to Data Set-up Time	T _{isu}	6	-	-	ns
Clock to Data Hold Time	T _{ih}	0	-	-	ns
Clock to Data Output Delay	T _{oa}	-	-	17	ns

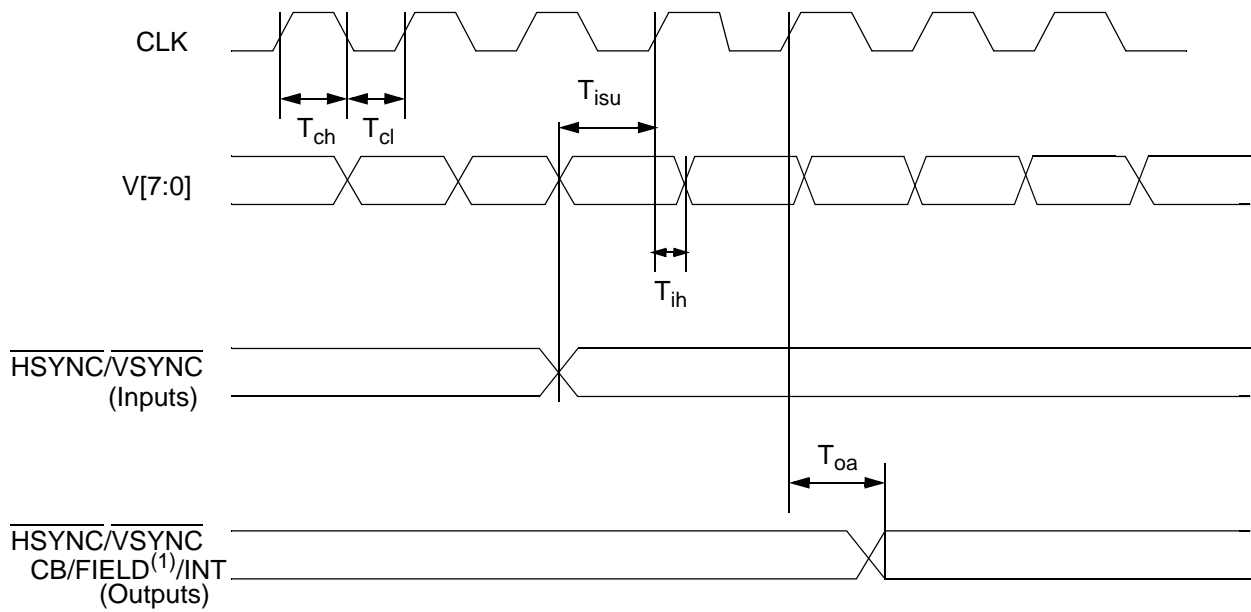

Figure 1. Video Pixel Data and Control Port Timing

TIMING CHARACTERISTICS

Parameter	Symbol	Min	Typ	Max	Units
I²C Host Port Timing (Figure 2)					
SCL Frequency	Fclk	100		1000	KHz
Clock Pulse High Time	Tsph	0.1			μs
Clock Pulse Low Time	Tspl	0.7			μs
Hold Time (Start Cond.)	Tsh	100			ns
Setup Time (Start Cond.)	Tssu	100			ns
Data Setup Time	Tsds	50			ns
Rise Time	Tsr			1	μs
Fall Time	Tsf			0.3	μs
Setup Time (Stop Cond.)	Tss	100			ns
Bus Free Time	Tbuf	100			ns
Data Hold Time	Tdh	0			ns
SCL Low to Data Out Valid	Tvdo			600	ns

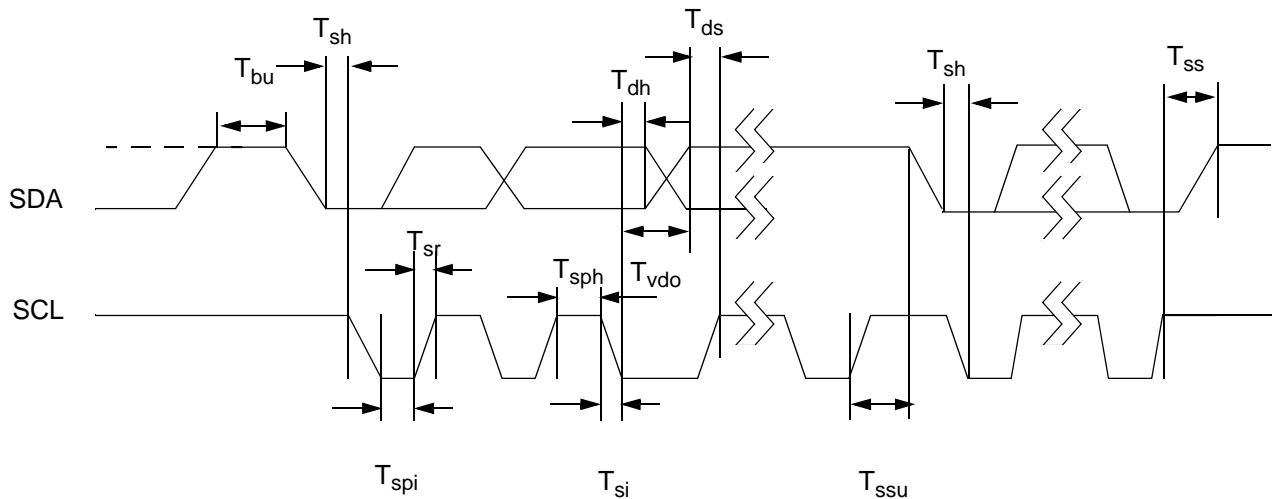
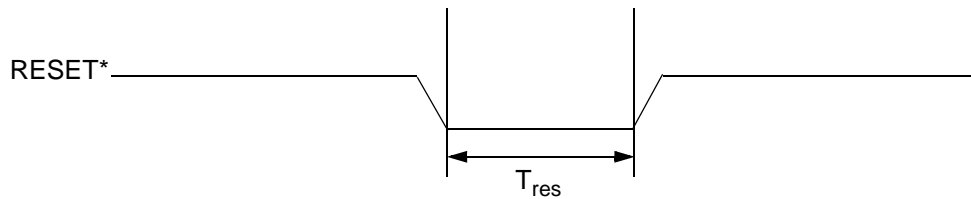

Figure 2. I²C Host Port Timing

TIMING CHARACTERISTICS(Continued)

<i>Parallel Host Port Timing (Figure 27, 28, 29)</i>	Symbol	Min	Typ	Max	Units
Read Cycle Time	Trd	60	-	-	ns
Read Pulse Width	Trpw	30	-	-	ns
Address Setup Time	Tas	3	-	-	ns
Read Address Hold Time	Trah	10	-	-	ns
Read Data Access Time	Trda	-	-	40	ns
Read Data Hold Time	Trdh	10	-	50	ns
Write Recovery Time	Twr	60	-	-	ns
Write Pulse Width	Twpw	40	-	-	ns
Write Data Setup Time	Twds	8	-	-	ns
Write Data Hold Time	Twdh	3	-	-	ns
Write-Read/Read-Write Recovery Time	Trec	50	-	-	ns
Address from Write Hold Time	Twac	0	-	-	ns
Reset Timing (Figure 3)					
Reset Pulse Width	Tres	100			ns

Figure 3. Reset Timing

2. ADDITIONAL CS4954/5 FEATURES

- Five programmable DAC output combinations, including YUV and second composite
- Optional progressive scan @ MPEG2 field rates
- Stable color subcarrier for MPEG2 systems
- General purpose input and output pins
- Individual DAC power-down capability
- On-chip color bar generator
- Supports RS170A and ITU R.BT601 composite output timing
- HSYNC and VSYNC output in ITU R.BT656 mode
- Teletext encoding selectable on two composite and S-video signals
- Programmable saturation, SCH Phase, hue, brightness and contrast
- Device power-down capability
- Super White and Super Black support

3. CS4954 INTRODUCTION

The CS4954/5 is a complete multi-standard digital video encoder implemented in current CMOS technology. The device can operate at 5 V as well as at 3.3 V. ITU R.BT601- or ITU R.BT656-compliant digital video input is converted into NTSC-M, NTSC-J, PAL-B, PAL-D, PAL-G, PAL-H, PAL-I, PAL-M, PAL-N, or PAL-N Argentina-compatible analog video. The CS4954/5 is designed to connect, without glue logic, to MPEG1 and MPEG2 digital video decoders.

Two 10-bit DAC outputs provide high quality S-Video analog output while another 10-bit DAC simultaneously generates composite analog video. In addition, there are three more DACs to provide simultaneous analog RGB or analog YUV outputs. The CS4954/5 will accept 8-bit YCbCr or 8-bit YUV input data.

The CS4954/5 is completely configured and controlled via an 8-bit host interface port or an I²C compatible serial interface. This host port provides access and control of all CS4954/5 options and features, such as closed caption insertion, interrupts, etc.

In order to lower overall system costs, the CS4954/5 provides an internal voltage reference that eliminates the requirement for an external, discrete, three-pin voltage reference.

In ISO MPEG-2 system configurations, the CS4954/5 can be augmented with a common color-burst crystal to provide a stable color subcarrier given an unstable 27 MHz clock input. The use of the crystal is optional, but the facility to connect one is provided for MPEG-2 environments in which the system clock frequency variability is too wide for accurate color sub-carrier generation.

4. FUNCTIONAL DESCRIPTION

In the following subsections, the functions of the CS4954/5 will be described. The descriptions refer to the device elements shown in the block diagram on the cover page.

4.1 Video Timing Generator

All timing generation is accomplished via a 27 MHz input applied to the CLK pin. The CS4954/5 can also accept a signal from an optional color burst crystal on the XTAL_IN & XTAL_OUT pins. See the section, Color Subcarrier Synthesizer, for further details.

The Video Timing Generator is responsible for orchestrating most of the other modules in the device. It operates in harmony with external sync input timing, or it can provide external sync timing outputs. It automatically disables color burst on appropriate scan lines and automatically generates serration and equalization pulses on appropriate scan lines.

The CS4954/5 is designed to function as a video timing master or video timing slave. In both Master and Slave Modes, all timing is sampled and asserted with the rising edge of the CLK pin.

In most cases, the CS4954/5 will serve as the video timing master. $\overline{\text{HSYNC}}$, $\overline{\text{VSYNC}}$, and $\text{FIELD}^{(1)}$ are configured as outputs in Master Mode. $\overline{\text{HSYNC}}$ or FIELD can also be defined as a composite blanking output signal in Master Mode. In Master Mode, the timing of $\overline{\text{HSYNC}}$, $\overline{\text{VSYNC}}$, FIELD and Composite Blank (CB) signals is programmable. Exact horizontal and vertical display timing is addressed in the Operational Description section.

In Slave Mode, $\overline{\text{HSYNC}}$ and $\overline{\text{VSYNC}}$ are typically configured as input pins and are used to initialize independent vertical and horizontal timing generators upon their respective falling edges. $\overline{\text{HSYNC}}$ and $\overline{\text{VSYNC}}$ timing must conform to the ITU-R BT.601 specifications.

The CS4954/5 also provides a ITU R.BT656 Slave Mode in which the video input stream contains EAV and SAV codes. In this case, proper $\overline{\text{HSYNC}}$ and $\overline{\text{VSYNC}}$ timing are extracted automatically without any inputs other than the V [7:0]. ITU R.BT656 input data is sampled with the leading edge of CLK.

In addition, it is also possible to output $\overline{\text{HSYNC}}$ and $\overline{\text{VSYNC}}$ signals during CCIR-656 Slave Mode.

4.2 Video Input Formatter

The Video Input Formatter translates YCbCr input data into YUV information, when necessary, and splits the luma and chroma information for filtering, scaling, and modulation.

4.3 Color Subcarrier Synthesizer

The subcarrier synthesizer is a digital frequency synthesizer that produces the appropriate subcarrier frequency for NTSC or PAL. The CS4954/5

generates the color burst frequency based on the CLK input (27 MHz). Color burst accuracy and stability are limited by the accuracy of the 27 MHz input. If the frequency varies, then the color burst frequency will also vary accordingly.

For environments in which the CLK input varies or jitters unacceptably, a local crystal frequency reference can be used on the XTAL_IN and XTAL_OUT pins. In this instance, the input CLK is continuously compared with the external crystal reference input and the internal timing of the CS4954/5 is automatically adjusted so that the color burst frequency remains within tolerance.

Controls are provided for phase adjustment of the burst to permit color adjustment and phase compensation. Chroma hue control is provided by the CS4954/5 via a 10-bit Hue Control Register (HUE_LSB and H_MSB). Burst amplitude control is also made available to the host via the 8-bit burst amplitude register (SC_AMP).

4.4 Chroma Path

The Video Input Formatter delivers 4:2:2 YUV outputs into separate chroma and luma data paths. The chroma path will be discussed here.

The chroma output of the Video Input Formatter is directed to a chroma low-pass 19-tap FIR filter. The filter bandwidth is selected (or the filter can be bypassed) via the CONTROL_1 Register. The passband of the filter is either 650 KHz or 1.3 MHz and the passband ripple is less than or equal to 0.05 dB. The stopband for the 1.3 MHz selection begins at 3 MHz with an attenuation of greater than 35 dB. The stopband for the 650 KHz selection begins around 1.1 MHz with an attenuation of greater than 20 dB.

The output of the chroma low-pass filter is connected to the chroma interpolation filter in which up-sampling from 4:2:2 to 4:4:4 is accomplished. Following the interpolation filter, the U and V

NOTE 1. The FIELD pin (pin 9) remains an output pin in SLAVE mode. However, the FIELD pin state does not toggle in SLAVE mode and its output state should be considered random.

chroma signals pass through two independent variable gain amplifiers in which the chroma amplitude can be varied via the U_AMP and V_AMP 8-bit host addressable registers.

The U and V chroma signals are fed to a quadrature modulator in which they are combined with the output from the subcarrier synthesizer to produce the proper modulated chrominance signal.

The chroma then is interpolated by a factor of two in order to operate the output DACs at twice the pixel rate. The interpolated filters enable running the DACs at twice the pixel rate and this helps reduce the $\sin x/x$ roll-off for higher frequencies and reduces the complexity of the external analog low pass filters.

4.5 Luma Path

Along with the chroma output path, the CS4954/5 Video Input Formatter initiates a parallel luma data path by directing the luma data to a digital delay line. The delay line is built as a digital FIFO in which the depth of the FIFO replicates the clock period delay associated with the more complex chroma path. Brightness adjustment is also provided via the 8-bit BRIGHTNESS_OFFSET Register.

Following the luma delay, the data is passed through an interpolation filter that has a programmable bandwidth, followed by a variable gain amplifier in which the luma DC values are modifiable via the Y_AMP Register.

The output of the luma amplifier connects to the sync insertion block. Sync insertion is accomplished by multiplexing, into the luma data path, the different sync DC values at the appropriate times. The digital sync generator takes horizontal sync and vertical sync timing signals and generates the appropriate composite sync timing (including vertical equalization and serration pulses), blanking information, and burst flag. The sync edge rates conform to RS-170A or ITU R.BT601 and ITU R.BT470 specifications.

It is also possible to delay the luminance signal, with respect to the chrominance signal, by up to three pixel clocks. This variable delay is useful to offset different propagation delays of the luma baseband and modulated chroma signals. This adjustable luma delay is available only on the CVBS_1 output.

4.6 RGB Path and Component YUV Path

The RGB datapath has the same latency as the luma and chroma path. Therefore all six simultaneous analog outputs are synchronized. The 4:2:2 YCbCr data is first interpolated to 4:4:4 and then interpolated to 27 MHz. The color space conversion is performed at 27 MHz. The coefficients for the color space conversion conform to the ITU R.BT601 specifications.

After color space conversion, the amplitude of each component can be independently adjusted via the R_AMP, G_AMP, and B_AMP 8-bit host addressable registers. A synchronization signal can be added to either one, two or all of the RGB signals. The synchronization signal conforms to NTSC or PAL specifications.

Some applications (e.g., projection TVs) require analog component YUV signals. The chip provides a programmable mode that outputs component YUV data. Sync can be added to the luminance signal. Independent gain adjustment of the three components is provided as well.

4.7 Digital to Analog Converters

The CS4954/5 provides six discrete 27 MHz DACs for analog video. The default configuration is one 10-bit DAC for S-video chrominance, one 10-bit DAC for S-Video luminance, one 10-bit DAC for composite output, and three 10-bit DACs for RGB outputs. All six DACs are designed for driving either low-impedance loads (double terminated 75 Ω) or high-impedance loads (double terminated 300 Ω). There are five different DAC configurations to choose from (see Table 1, below).

DAC	Pin #	Mode 1	Mode 2	Mode 3	Mode 4	Mode 5
Y	48	Y	Y	Y	CVBS_2	CVBS_2
C	47	C	C	C	-	-
CVBS	44	CVBS_1	CVBS_1	CVBS_1	CVBS_1	CVBS_1
R	39	R	Cr (V)	-	R	Cr (V)
G	40	G	Y	CVBS_2	G	Y
B	43	B	Cb (U)	-	B	Cb (U)

Table 1. DAC configuration Modes

The DACs can be put into high-impedance mode via host-addressable control register bits. Each of the six DACs has its own associated DAC enable bit. In the Disable Mode, the 10-bit DACs source (or sink) zero current.

When running the DACs with a low-impedance load, a minimum of three DACs must be powered down. When running the DACs with a high-impedance load, all the DACs can be enabled simultaneously.

For lower power standby scenarios, the CS4954/5 also provides power shut-off control for the DACs. Each DAC has an associated DAC shut-off bit.

4.8 Voltage Reference

The CS4954/5 is equipped with an on-board voltage reference generator (1.232 V) that is used by the DACs. The internal reference voltage is accurate enough to guarantee a maximum of 3% overall gain error on the analog outputs. However, it is possible to override the internal reference voltage by applying an external voltage source to the VREF pin.

4.9 Current Reference

The DAC output current-per-bit is derived in the current reference block. The current step is specified by the size of resistor placed between the ISET current reference pin and electrical ground.

A 4 k Ω resistor needs to be connected between ISET pin and GNDA. The DAC output currents are optimized to either drive a doubly terminated load of 75 Ω (low impedance mode) or a double termi-

nated load of 300 Ω (high impedance mode). The 2 output current modes are software selectable through a register bit.

4.10 Host Interface

The CS4954/5 provides a parallel 8-bit data interface for overall configuration and control. The host interface uses active-low read and write strobes, along with an active-low address enable signal, to provide microprocessor-compatible read and write cycles. Indirect host addressing to the CS4954/5 internal registers is accomplished via an internal address register that is uniquely accessible via bus write cycles in which the host address enable signal is asserted.

The CS4954/5 also provides an I²C-compatible serial interface for device configuration and control. This port can operate in standard (100Kb/sec) or fast (400 Kb/sec) modes. When in I²C mode, the parallel data interface pins, PDAT [7:0], can be used as a general purpose I/O port controlled by the I²C interface.

4.11 Closed Caption Services

The CS4954/5 supports the generation of NTSC Closed Caption services. Line 21 and Line 284 captioning can be generated and enabled independently via a set of control registers. When enabled, clock run-in, start bit, and data bytes are automatically inserted at the appropriate video lines. A convenient interrupt protocol simplifies the software interface between the host processor and the CS4954/5.

4.12 Teletext Services

The CS4954/5 encodes the most common teletext formats, such as European Teletext, World Standard Teletext (PAL and NTSC), and North American Teletext (NABTS).

Teletext data can be inserted in any of the TV lines (blanking lines as well as active lines). In addition the blanking lines can be individually allocated for Teletext instantiation.

The input timing for teletext data is user programmable. See the section *Teletext Services* for further details.

Teletext data can be independently inserted on either one or all of the CVBS_1, CVBS_2, or S-video signals.

4.13 Wide-Screen Signaling Support and CGMS

Insertion of wide-screen signal encoding for PAL and NTSC standards is supported and CGMS (Copy Generation Management System) for NTSC in Japan. Wide-screen signals are inserted in lines 23 and 336 for PAL, and lines 20 and 283 for NTSC.

4.14 VBI Encoding

This chip supports the transmission of control signals in the vertical blanking time interval according to SMPTE RP 188 recommendations. VBI encoded data can be independently inserted into either or all of CVBS_1, CVBS_2 or S-video signals.

4.15 Control Registers

The control and configuration of the CS4954/5 is accomplished primarily through the control register block. All of the control registers are uniquely addressable via the internal address register. The control register bits are initialized during device RESET.

See the Programming section of this data sheet for the individual register bit allocations, bit operational descriptions, and initialization states.

4.16 Testability

The digital circuits are completely scanned by an internal scan chain, thus providing close to 100% fault coverage.

5. OPERATIONAL DESCRIPTION

5.1 Reset Hierarchy

The CS4954/5 is equipped with an active low asynchronous reset input pin, $\overline{\text{RESET}}$. $\overline{\text{RESET}}$ is used to initialize the internal registers and the internal state machines for subsequent default operation. See the electrical and timing specification section of this data sheet for specific CS4954/5 device RESET and power-on signal timing requirements and restrictions.

While the $\overline{\text{RESET}}$ pin is held low, the host interface in the CS4954/5 is disabled and will not respond to host-initiated bus cycles. All outputs are valid after a time period following $\overline{\text{RESET}}$ pin low.

A device RESET initializes the CS4954/5 internal registers to their default values as described by Table 9, Control Registers. In the default state, the CS4954/5 video DACs are disabled and the device is internally configured to provide blue field video data to the DACs (any input data present on the V [7:0] pins is ignored at this time). Otherwise, the CS4954/5 registers are configured for NTSC-M ITU R.BT601 output operation. At a minimum, the DAC Registers (0x04 and 0x05) must be written (to enable the DACs) and the IN_MODE bit of the CONTROL_0 Register (0x01) must be set (to enable ITU R.BT601 data input on V [7:0]) for the CS4954/5 to become operational after RESET.

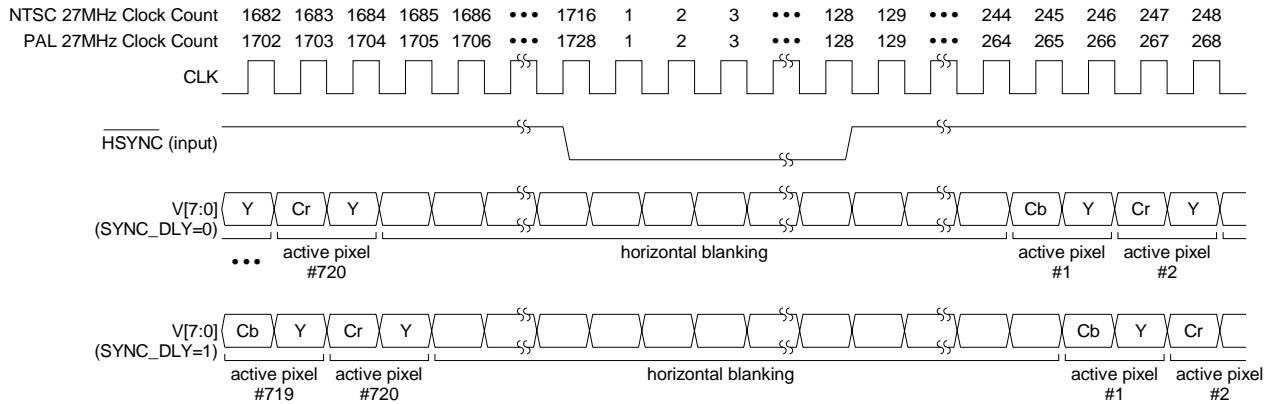

Figure 4. ITU R.BT601 Input Slave Mode Horizontal Timing

5.2 Video Timing

5.2.1 Slave Mode Input Interface

In Slave “601” (non “656” input) Mode, the CS4954/5 receives signals on $\overline{\text{VSYNC}}$ and $\overline{\text{HSYNC}}$ as inputs. Slave Mode is the default following RESET and is changed to Master Mode via a control register bit (CONTROL_0 [4]). The CS4954/5 is limited to ITU R.BT601 horizontal and vertical input timing. All clocking in the CS4954/5 is generated from the CLK pin. In Slave Mode, the Sync Generator uses externally provided horizontal and vertical sync signals to synchronize the internal timing of the CS4954/5. Video data that is sent to the CS4954/5 must be synchronized to the horizontal and vertical sync signals. Figure 4 illustrates horizontal timing for ITU R.BT601 input in Slave Mode. Note that the CS4954/5 expects to receive the first active pixel data on clock cycle 245

(NTSC) when CONTROL_2 Register (0x02) bit SYNC_DLY = 0. When SYNC_DLY = 1, it expects the first active pixel data on clock cycle 246 (NTSC).

5.2.2 Master Mode Input Interface

The CS4954/5 defaults to Slave Mode following RESET high but can be switched into Master Mode via the MSTR bit in the CONTROL_0 Register (0x00). In Master Mode, the CS4954/5 uses the $\overline{\text{VSYNC}}$, $\overline{\text{HSYNC}}$ and FIELD device pins as outputs to schedule the proper external delivery of digital video into the V [7:0] pins. Figure 5 illustrates horizontal timing for the CCIR601 input in Master Mode.

The timing of the $\overline{\text{HSYNC}}$ output is selectable in the PROG_HS Registers (0x0D, 0x0E). $\overline{\text{HSYNC}}$ can be delayed by one full line cycle. The timing of the $\overline{\text{VSYNC}}$ output is also selectable in the

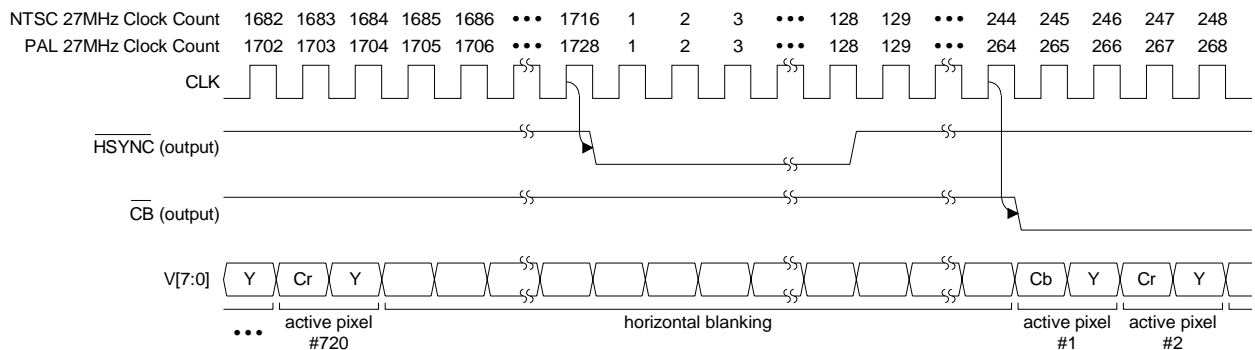

Figure 5. ITU R.BT601 Input Master Mode Horizontal Timing

PROG_VS Register (0x0D). $\overline{\text{VSYNC}}$ can be delayed by thirteen lines or advanced by eighteen lines.

5.2.3 Vertical Timing

The CS4954/5 can be configured to operate in any of four different timing modes: PAL, which is 625 vertical lines, 25 frames per second interlaced; NTSC, which is 525 vertical lines, 30 frames per second interlaced; and either PAL or NTSC in Progressive Scan, in which the display is non-interlaced. These modes are selected in the CONTROL_0 Register (0x00).

The CS4954/5 conforms to standard digital decompression dimensions and does not process digital input data for the active analog video half lines as they are typically in the over/underscan region of televisions. 240 active lines total per field are processed for NTSC, and 288 active lines total per field are processed for PAL. Frame vertical dimensions are 480 lines for NTSC and 576 lines for PAL. Table 2 specifies active line numbers for both NTSC and PAL. Refer to Figure 6 for $\overline{\text{HSYNC}}$, $\overline{\text{VSYNC}}$ and FIELD signal timing.

Mode	Field	Active Lines
NTSC	1, 3; 2, 4	22-261; 285-524
PAL	1, 3, 5, 7; 2, 4, 6, 8	23-310; 336-623
NTSC Progressive-Scan	NA	22-261
PAL Progressive-Scan	NA	23-310

Table 2. Vertical Timing

5.2.4 Horizontal Timing

$\overline{\text{HSYNC}}$ is used to synchronize the horizontal-input-to-output timing in order to provide proper horizontal alignment. $\overline{\text{HSYNC}}$ defaults to an input pin following RESET but switches to an output in Master Mode (CONTROL_0 [4] = 1). Horizontal timing is referenced to $\overline{\text{HSYNC}}$ transitioning low. For active video lines, digital video input is to be applied to the V [7:0] inputs for 244 (NTSC) or for 264 (PAL) CLK periods following the leading

(falling) edge of $\overline{\text{HSYNC}}$ if the PROG_HS Registers are set to default values.

5.2.5 NTSC Interlaced

The CS4954/5 supports NTSC-M, NTSC-J and PAL-M modes where there are 525 total lines per frame and two fixed 262.5-line fields per frame and 30 total frames occurring per second. NTSC interlaced vertical timing is illustrated in Figure 7. Each field consists of one line for closed caption, 240 active lines of video, plus 21.5 lines of blanking.

$\overline{\text{VSYNC}}$ field one transitions low at the beginning of line four and will remain low for three lines or 2574 pixel cycles (858×3). The CS4954/5 exclusively reserves line 21 of field one for closed caption insertion. Digital video input is expected to be delivered to the CS4954/5 V [7:0] pins for 240 lines beginning on active video lines 22 and continuing through line 261. $\overline{\text{VSYNC}}$ field two transitions low in the middle of line 266 and stays low for three line-times and transitions high in the middle of line 269. The CS4954/5 exclusively reserves line 284 of field two for closed caption insertion. Video input on the V [7:0] pins is expected between lines 285 through line 525.

5.2.6 PAL Interlaced

The CS4954/5 supports PAL modes B, D, G, H, I, N, and Combination N, in which there are 625 total lines per frame, two fixed 312.5 line fields per frame, and 25 total frames per second. Figure 8 illustrates PAL interlaced vertical timing. Each field consists of 287 active lines of video plus 25.5 lines of blanking.

$\overline{\text{VSYNC}}$ will transition low to begin field one and will remain low for 2.5 lines or 2160 pixel cycles (864×2.5). Digital video input is expected to be delivered to the CS4954/5 V [7:0] pins for 287 lines beginning on active video line 24 and continuing through line 310.

Field two begins with $\overline{\text{VSYNC}}$ transitioning low after 312.5 lines from the beginning of field one.

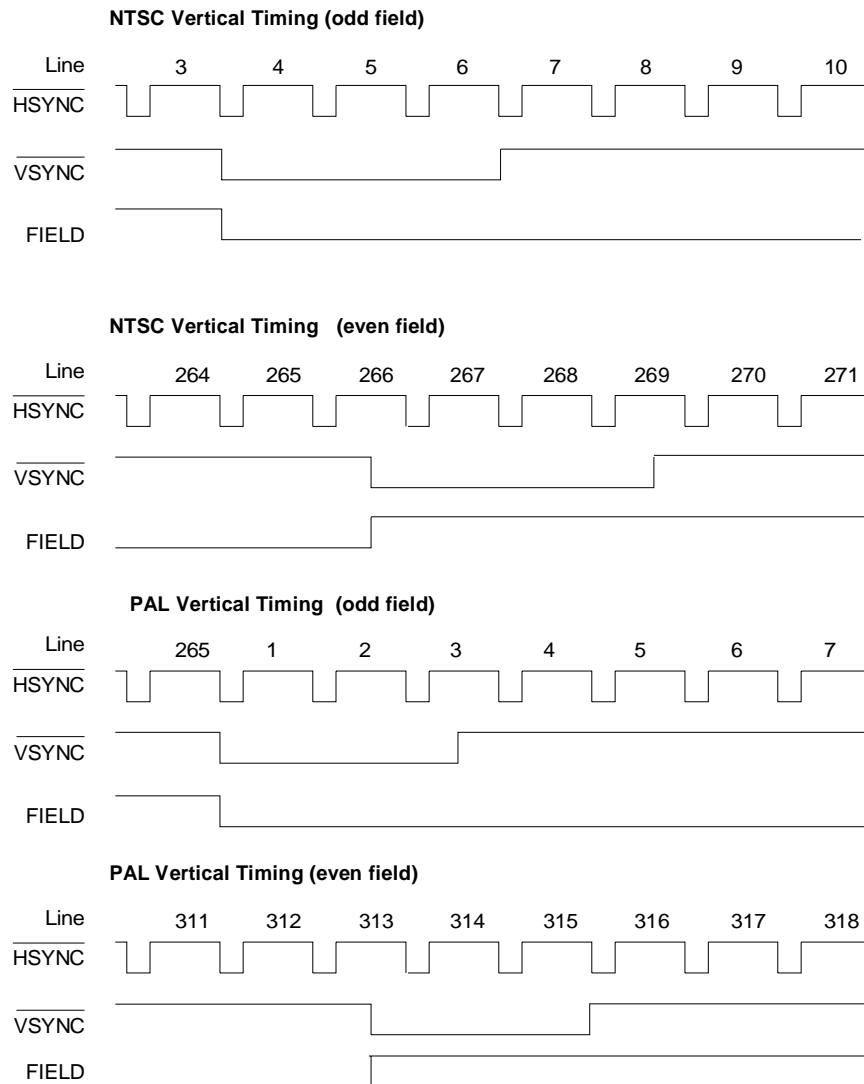

Figure 6. Vertical Timing

$\overline{\text{VSYNC}}$ stays low for 2.5 line-times and transitions high with the beginning of line 315. Video input on the V [7:0] pins is expected between line 336 through line 622.

5.2.7 Progressive Scan

The CS4954/5 supports a progressive scan mode in which the video output is non-interlaced. This is accomplished by displaying only the odd video field for NTSC or PAL. To preserve precise MPEG-2 frame rates of 30 and 25 per second, the CS4954/5 displays the same odd field repetitively but alternately varies the field times. This mode is in contrast to other digital video encoders, which

commonly support progressive scan by repetitively displaying a 262 line field (524/525 lines for NTSC). The common method is flawed: over time, the output display rate will overrun a system-clock-locked MPEG-2 decompressor and display a field twice every 8.75 seconds.

5.2.8 NTSC Progressive Scan

$\overline{\text{VSYNC}}$ will transition low at line four to begin field one and will remain low for three lines or 2574 pixel cycles (858×3). NTSC interlaced timing is illustrated in Figure 9. In this mode, the CS4954/5 expects digital video input at the V [7:0]

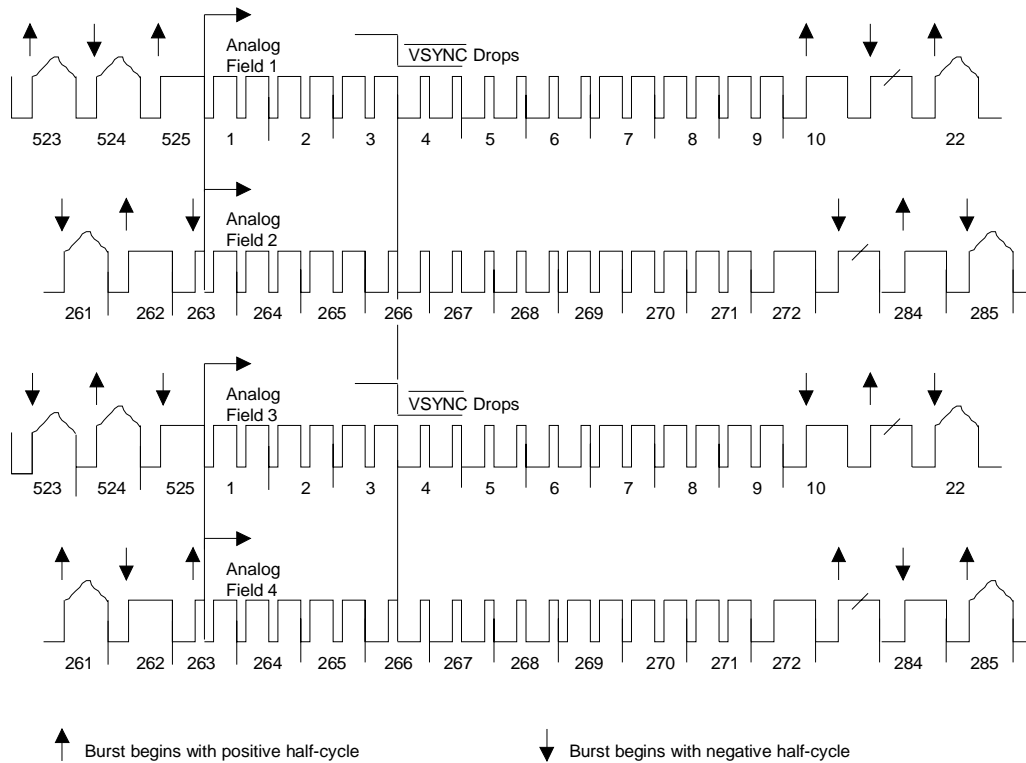

Figure 7. NTSC Video Interlaced Timing

pins for 240 lines beginning on active video line 22 and continuing through line 261.

Field two begins with $\overline{\text{VSYNC}}$ transitioning low at line 266. $\overline{\text{VSYNC}}$ stays low for 3 line cycles and transitions high during the end of line 268. Video input on the V [7:0] pins is expected between line 284 and line 522. Field two is 263 lines; field one is 262 lines.

5.2.9 PAL Progressive Scan

$\overline{\text{VSYNC}}$ will transition low at the beginning of the odd field and will remain low for 2.5 lines or 2160 pixel cycles (864×2.5). PAL non-interlaced timing is illustrated in Figure 10. In this mode, the CS4954/5 expects digital video input on the V [7:0] pins for 288 lines, beginning on active video line 23 and continuing through line 309.

The second begins with $\overline{\text{VSYNC}}$ transitioning low after 312 lines from the beginning of the first field. $\overline{\text{VSYNC}}$ stays low for 2.5 line-times and transitions

high during the middle of line 315. Video input on the V [7:0] pins is expected between line 335 through line 622. Field two is 313 lines; field one is 312 lines.

5.3 ITU-R.BT656

The CS4954/5 supports an additional ITU-R.BT656 slave mode feature that is selectable through the ITU-R.BT656 bit of the CONTROL_0 Register. The ITU-R.BT656 slave feature is unique because the horizontal and vertical timing and digital video are combined into a single 8-bit 27 MHz input. With ITU-R.BT656 there are no horizontal and vertical input or output strobes, only 8-bit 27 MHz active CbYCrY data, with start- and end-of-video codes implemented using reserved 00 and FF code sequences within the video feed. As with all modes, V [7:0] are sampled with the rising edge of CLK. The CS4954/5 expects the digital ITU-R.BT656 stream to be error-free. The FIELD⁽¹⁾

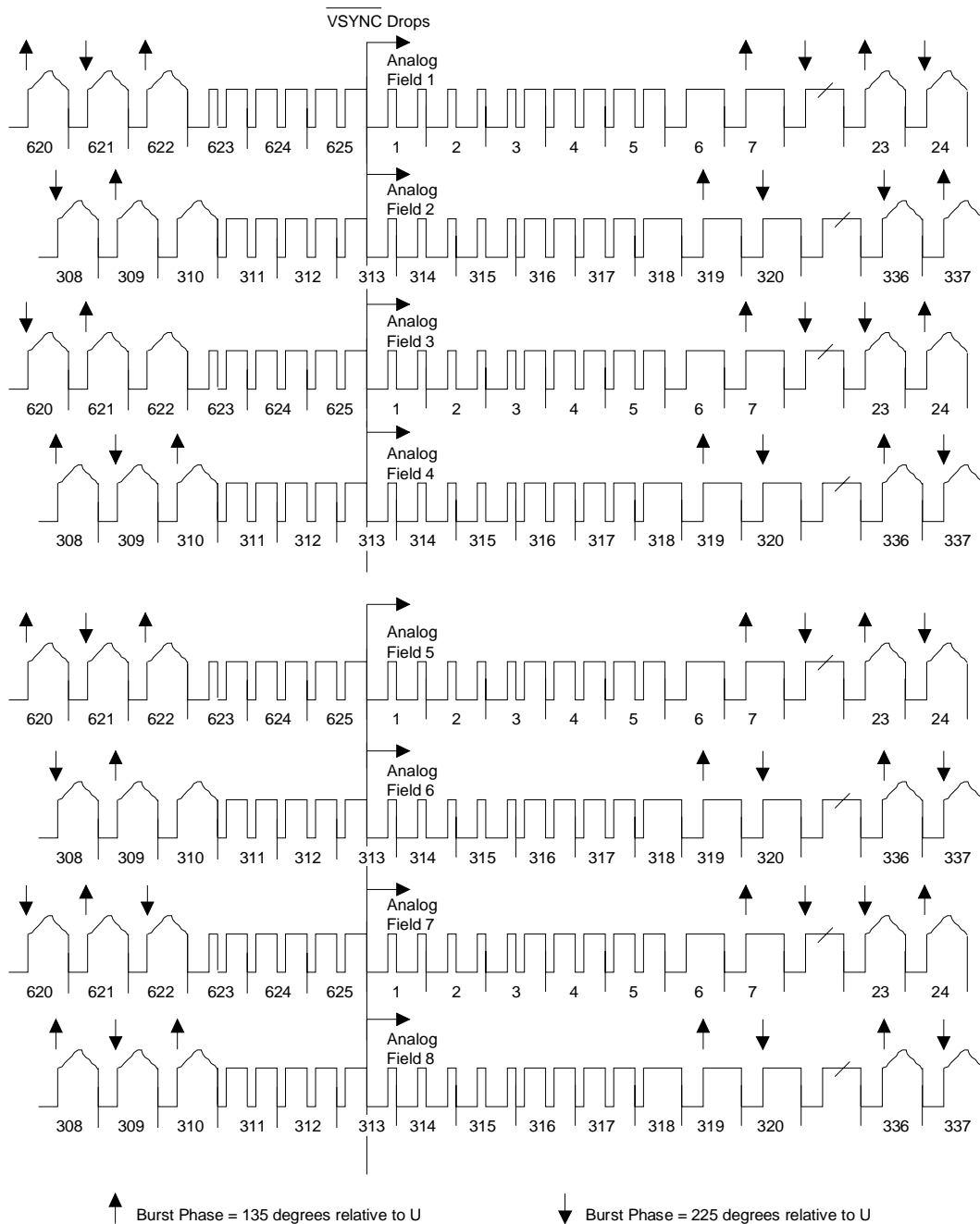

Figure 8. PAL Video Interlaced Timing

output toggles as with non ITU-R.BT656 input. ITU-R.BT656 input timing is illustrated in Figure 11.

As mentioned above, there are no horizontal and vertical timing signals necessary in ITU-R.BT656 mode. However in some cases it is advantageous to

output these timing signals for other purposes. By setting the 656_SYNC_OUT register bit in CONTROL_6 register, HSYNC and VSYNC are output, so that other devices in the system can synchronize to these timing signals.

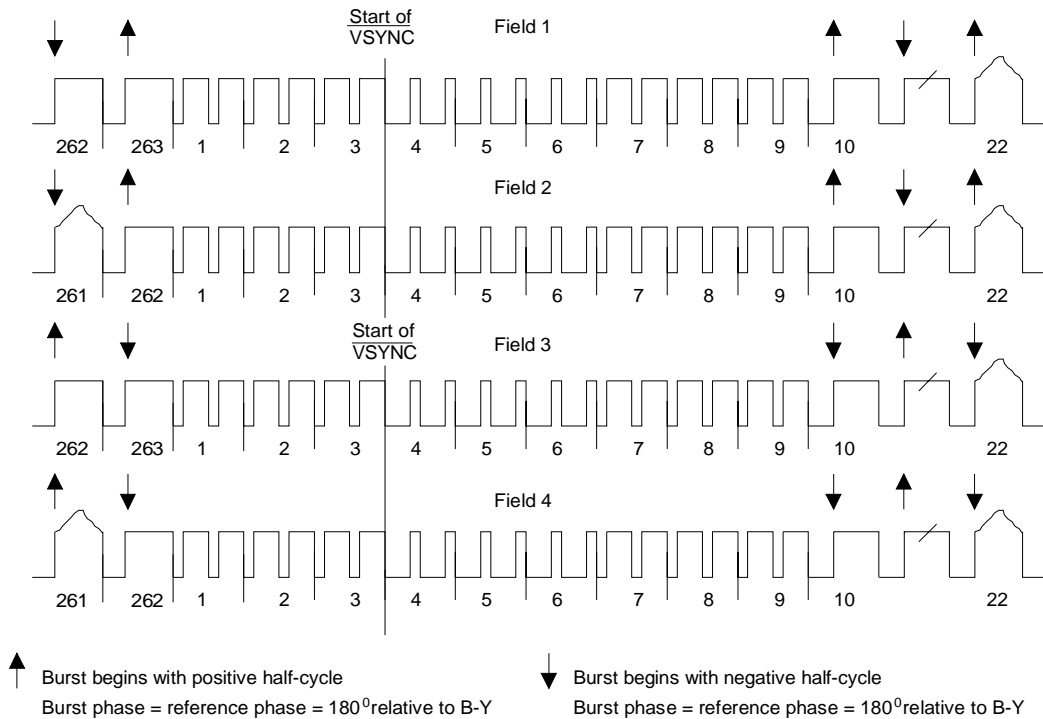

Figure 9. NTSC Video Non-Interlaced Progressive Scan Timing

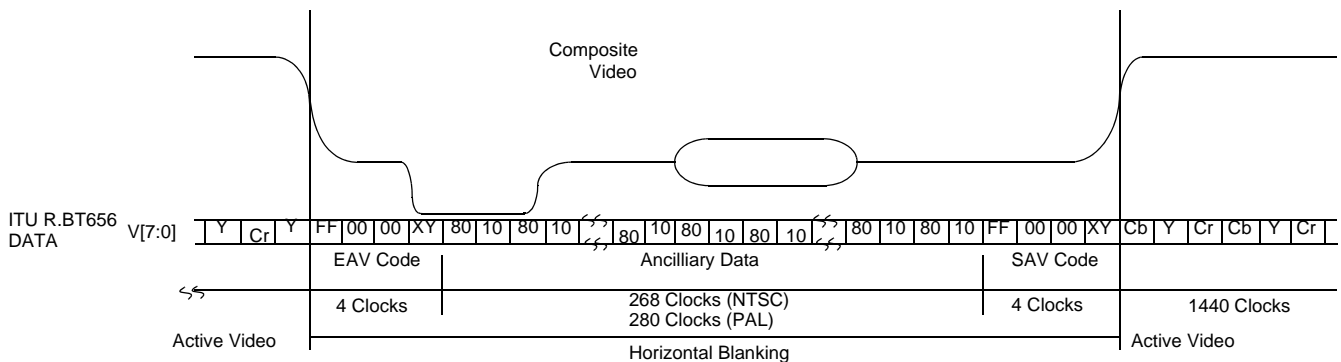

Figure 11. CCIR656 Input Mode Timing

5.4 Digital Video Input Modes

The CS4954/5 provides two different digital video input modes that are selectable through the IN_MODE bit in the CONTROL_0 Register.

In Mode 0 and upon RESET, the CS4954/5 defaults to output a solid color (one of a possible of 256 colors). The background color is selected by writing the BKG_COLOR Register (0x08). The colorspace of the register is RGB 3:3:2 and is unaf-

ected by gamma correction. The default color following RESET is blue.

In Mode 1 the CS4954/5 supports a single 8-bit 27 MHz CbYCrY source as input on the V [7:0] pins. Input video timing can be ITU-R.BT601 master or slave and ITU-R.BT656.

5.5 Multi-standard Output Format Modes

The CS4954/5 supports a wide range of output formats compatible with worldwide broadcast stan-

NOTE 1: The FIELD pin (pin 9) remains an output pin in SLAVE mode. However, the FIELD pin state does not toggle in SLAVE mode and its output state should be considered random.

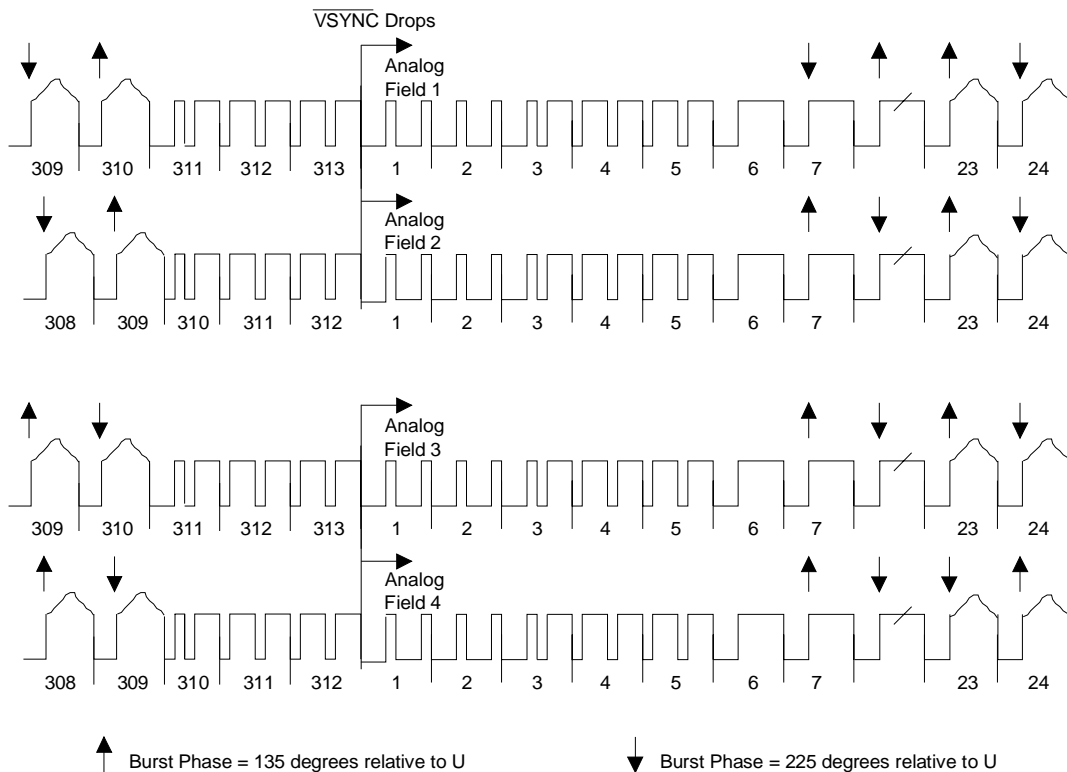

Figure 10. PAL Video Non-Interlaced Progressive Scan Timing

dards. These formats include NTSC-M, NTSC-J, PAL-B/D/G/H/I, PAL-M, PAL-N, and PAL Combination N (PAL-Nc) which is the broadcast standard used in Argentina. After RESET, the CS4954/5 defaults to NTSC-M operation with ITU R.BT 601 analog timing. NTSC-J can also be supported in the Japanese format by turning off the 7.5 IRE pedestal through the PED bit in the CONTROL_1 Register (0x01).

Output formats are configured by writing control registers with the values shown in Table 3.

5.6 Subcarrier Generation

The CS4954/5 automatically synthesizes NTSC and PAL color subcarrier clocks using the CLK frequency and four control registers (SC_SYNTH0/1/2/3). The NTSC subcarrier synthesizer is reset every four fields (every eight fields for PAL).

The SC_SYNTH0/1/2/3 registers used together provide a 32-bit value that defaults to NTSC (43E0F83Eh) following RESET. Table 4 shows the 32-bit value required for each of the different broadcast formats.

System	Fsubcarrier	Value (hex)
NTSC-M, NTSC-J	3.5795455 MHz	43E0F83E
PAL-B, D, G, H, I, N	4.43361875 MHz	54131596
PAL-N (Argentina)	3.582056 MHz	43ED288D
PAL-M	3.579611 MHz	43CDDFC7

Table 3.

5.7 Subcarrier Compensation

Since the subcarrier is synthesized from CLK the subcarrier frequency error will track the clock frequency error. If the input clock has a tolerance of 200 ppm then the resulting subcarrier will also have a tolerance of 200 ppm. Per the NTSC speci-

fication, the final subcarrier tolerance is ± 10 Hz which is approximately 3 ppm. Care must be taken in selecting a suitable clock source.

In MPEG-2 system environments the clock is actually recovered from the data stream. In these cases the recovered clock can be 27 MHz ± 50 ppm or ± 1350 Hz. It varies per television, but in many cases given an MPEG-2 system clock of 27 MHz, ± 1350 Hz, the resultant color subcarrier produced will be outside of the television's ability to compensate and the chrominance information will not be displayed (resulting in a black-and-white picture only).

The CS4954/5 is designed to provide automatic compensation for an excessively inaccurate MPEG-2 system clock. Sub-carrier compensation is enabled through the XTAL bit of the CONTROL_2 Register. When enabled the CS4954/5 will utilize a common quartz color burst crystal (3.579545 MHz ± 50 ppm for NTSC) attached to the XTAL_IN and XTAL_OUT pins to automatically compare and compensate the color subcarrier synthesis process.

5.8 Closed Caption Insertion

The CS4954/5 is capable of NTSC Closed Caption insertion on lines 21 and 284 independently. Closed captioning is enabled for either one or both

lines via the CC_EN [1:0] Register bits and the data to be inserted is also written into the four Closed Caption Data registers. The CS4954/5, when enabled, automatically generates the seven cycles of clock run-in (32 times the line rate), start bit insertion (001), and finally insertion of the two data bytes per line. Data low at the video outputs corresponds to 0 IRE and data high corresponds to 50 IRE.

There are two independent 8-bit registers per line (CC_21_1 & CC_21_2 for line 21 and CC_284_1 & CC_284_2 for line 284). Interrupts are also provided to simplify the handshake between the driver software and the device. Typically the host would write all 4 bytes to be inserted into the registers and then enable closed caption insertion and interrupts. As the closed caption interrupts occur the host software would respond by writing the next two bytes to be inserted to the correct control registers and then clear the interrupt and wait for the next field.

5.9 Programmable H-sync and V-sync

It is possible in master mode to change the H-sync and V-sync times based on register settings. Programmable H-sync and V-sync timings are helpful in several digital video systems, where latencies of the control signals are present. The user can then program H-sync and V-sync timing according to

Address	Register	NTSC-M ITU R.BT601	NTSC-J ITU R.BT601	NTSC-M RS170A	PAL- B,D,G,H,I	PAL-M	PAL-N	PAL-N Comb. (Argent)
0x00	CONTROL_0	01h	01h	21h	41h	61h	A1h	81h
0x01	CONTROL_1	12h	10h	16h	30h	12h	30h	30h
0x04	CONTROL_4	07h	07h	07h	07h	07h	07h	07h
0x05	CONTROL_5	78h	78h	78h	78h	78h	78h	78h
0x10	SC_AMP	1Ch	1Ch	1Ch	15h	15h	15h	15h
0x11	SC_SYNTH0	3Eh	3Eh	3Eh	96h	C7h	96h	8Ch
0x12	SC_SYNTH1	F8h	F8h	F8h	15h	DFh	15h	28h
0x13	SC_SYNTH2	E0h	E0h	E0h	13h	CDh	13h	EDh
0x14	SC_SYNTH3	43h	43h	43h	54h	43h	54h	43h

Table 4. Multi-standard Format Register Configurations

their system requirements. The default values are 244, and 264 for NTSC and PAL respectively.

H-sync can be delayed by a full line, in 74 nsec intervals.

V-sync can be shifted in both directions in time. The default values are 18 and 23 for NTSC and PAL respectively. Since the V-sync register is 5 bits wide (Sync Register 0), the V-sync pulse can be shifted by 31 lines in total.

V-sync can precede by a maximum of 18 lines (NTSC) or 23 lines (PAL) respectively from its default location, and V-sync can follow by a maximum of 13 lines (NTSC) or 8 lines (PAL) from its default location.

5.10 Wide Screen Signaling (WSS) and CGMS

Wide screen signaling support is provided for NTSC and for PAL standards. Wide screen signaling is currently used in most countries with 625 line systems as well as in Japan for EDTV-II applications. For complete description of WSS standard, please refer to **ITU-R BT.1119** (625 line system) and to **EIAJ CPX1204** for the Japanese 525 line system.

The wide screen signal is transferred in a blanking line of each video field (NTSC: lines 20 and 283, PAL: lines 23 and 336). Wide screen signaling is enabled by setting WW_23 to “1”. Some countries with PAL standard don’t use line 336 for wide screen signaling (they use only line 23), therefore we provide another enable bit (WSS_22) for that particular line.

There are 3 registers dedicated to contain the transmitted WSS bits (WSS_REG_0, WSS_REG_1, WSS_REG_2). The data insertion into the appropriate lines are performed automatically by this device. The run-in and start code bits do not have to be loaded into this device, it automatically inserts the correct code at the beginning of transfer.

5.11 Teletext Support

This chip supports several teletext standards, like European teletext, NABTS (North American teletext), and WST (World Standard Teletext) for NTSC and PAL.

All these teletext standards are defined in the **ITU-R BT.653-2** document. The **European teletext** is defined as “**teletext system B**” for 625/50 Hz TV systems. **NABTS** teletext is defined as “**teletext system C**” for 525/60 Hz TV systems. **WST** for **PAL** is defined as “**teletext system D**” for 624/50 Hz TV systems and **WST** for **NTSC** is defined as “**teletext system D**” for 525/60 Hz TV systems.

This chip provides independent teletext encoding into composite 1, composite 2 and s-video signals. The teletext encoding into these various signals is software programmable.

In teletext pulsation mode, (TTX_WINDOW=0), register 0x31 bit 3, the pin TTXDAT receives a teletext bitstream sampled at the 27 Mhz clock. At each rising edge of the TTXRQ output signal a single teletext bit has to be provided after a programmable input delay at the TTXDAT input pin.

Phase variant interpolation is achieved on this bitstream in the internal teletext encoder, providing sufficient small phase jitter on the output text lines.

TTXRQ provides a fully programmable request signal to the teletext source, indicating the insertion period of the bitstream at independently selectable lines for both TV fields. The internal insertion window for text is set to either 360, 296 or 288 teletext bits, depending on the selected teletext standard. The clock run-in is included in this window.

Teletext is enabled by setting the TTX_EN bit to “1”. The TTX_WST bit in conjunction with the TV_FORMAT register select one of the 4 possible teletext encoding possibilities.

The teletext timing is shown in the Figure 12. TTXHS and TTXHD are user programmable and

therefore allow the user to have full control over to when sending teletext data to this device.

The time t_{FD} is the time needed to interpolate teletext input data and inserting it into the CVBS and Y output signals, such that it appears between $t_{TTX} = 9.8 \mu s$ and $t_{TTX} = 12 \mu s$ after the leading edge of the horizontal synchronization pulse. t_{FD} changes with the TV standard and the selected teletext standard. Please refer to ITU-R BT.653-2 for more detailed information.

The time t_{PD} is the pipeline delay time introduced by the source that is gated by TTXRQ in order to deliver teletext data. This delay is programmable through the register TTXHD. For every active HIGH transition at output pin TTXRQ, a new teletext bit must be provided by the source. The time between the beginning of the first TTXRQ pulse and the leading edge of H-sync is programmable through the TTXHS register.

Since the beginning of the pulses representing the TTXRQ signal and the delay between the rising edge of TTXRQ and valid teletext input data are fully programmable, the TTXDAT data is always inserted at the correct position after the leading edge of the outgoing horizontal synchronization pulse.

The time t_{TTXWin} is the internally used insertion window for TTX data; it has a constant length depending on the selected teletext standard which allows insertion of 360 TTX bits (6.9375 Mbit/sec) (European teletext) or 296 TTX bits

(5.6427875 Mbit/sec) (WST PAL) or 288 TTX bits (5.727272 Mbit/sec) (NABTS) or 296 TTX bits (5.727272 Mbit/sec) (WST NTSC) respectively.

Using the appropriate programming, all suitable lines of the odd field (TTXOVS through TTX-OVE) plus all suitable lines of the even field (TTXEVS through TTXEVE) can be used for teletext insertion. In addition it is possible to selectively disable the teletext insertion on single lines. This can be programmed by setting the TTX_LINE_DIS1, TTX_LINE_DIS2 and TTX_LINE_DIS3 registers appropriately.

Note that the TTXDAT signal must be synchronized with the 27 Mhz clock. The pulse width of the TTXRQ signal varies between three and four 27 Mhz clock cycles. The variation is necessary in order to maintain the strict timing requirements of the teletext standard.

Table 5 shows how to program the TTXHS register for teletext instantiation into the analog signals for the various supported TV formats. TTXHS is the time between the leading edge of the HSYNC signal and the rising edge of the first TTXRQ signal and consists of multiples of 27 Mhz clock cycles

Note that with increasing values of TTXHS the time t_{TTX} increases as well. The time t_{FD} accounts for the internal pipeline delay due to processing, synchronization and instantiation of the teletext data. The time t_{PD} is dependant on the TTXHD register.

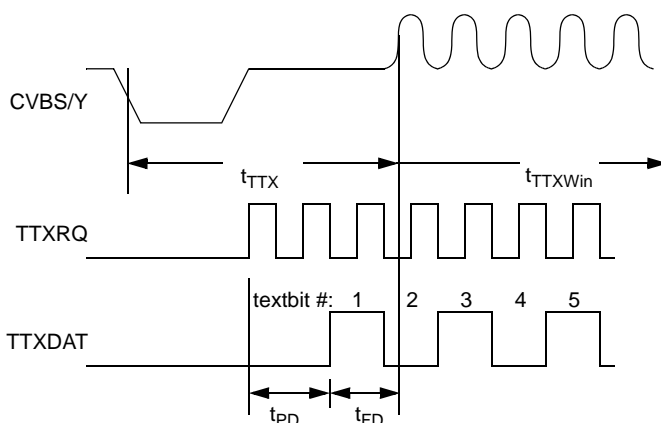

Figure 12. Teletext Timing (Pulsation Mode)

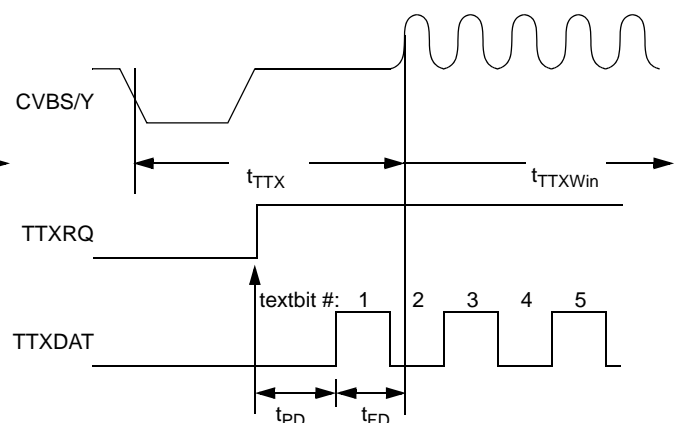

Figure 13. Teletext Timing (Window Mode)

Note that the teletext databits are shaped according to the ITU R.BT653-2 specifications.

If register 0x31 bit 3 is set, (TTX_WINDOW=1) the teletext is in windows mode, the request pulses become a window where the bit provided on the TTXDAT pin are valid (see Figure 13).

Alternately to the pulsation mode (where the number of request pulses are determined by the teletext standard chosen), the length of the window must be programmed by the user independently of the teletext standard used. The length of the window is programmed through register 0x29 TTXHS (start of window) and register 0x2A (TTXHD) and 0x31 (end of window). The end-of-window register is a 11 bit value.

In teletext window mode, the TTXHS value can be selected using the values in Table 5. Although these values may need to be adjusted to match your system delay, use the following equation to compute the TTXHD value:

$$\text{TTXHS} + 1402 = \text{TTXHD} \text{ (for Europe)}$$

$$\text{TTXHS} + 1151 = \text{TTXHD} \text{ (for WST)}$$

$$\text{TTXHS} + 1122 = \text{TTXHD} \text{ (for NABTS)}$$

TV standard	Teletext standard	TTXHS (register value)	t _{TTX}
NTSC-M	NABTS	161	10.5 μs
NTSC-M	WST-NTSC	142	9.8 μs
PAL-B	Europe TTX	204	12.0 μs
PAL-B	WST-PAL	163	10.5 μs
PAL-M	NABTS	161	10.5 μs
PAL-M	WST-NTSC	142	9.8 μs
PAL-N (non Arg.)	Europe TTX	204	12.0 μs
PAL-N (non Arg.)	WST-PAL	163	10.5 μs
PAL-N (Arg.)	Europe TTX	204	12.0 μs
PAL-N (Arg.)	WST-PAL	163	10.5 μs

Table 5. Teletext timing parameters

5.12 Color Bar Generator

The CS4954/5 is equipped with a color bar generator that is enabled through the CBAR bit of the

CONTROL_1 Register. The color bar generator works in master or Slave Mode and has no effect on the video input/output timing. If the CS4954/5 is configured for Slave Mode color bars, proper video timing must be present on the $\overline{\text{HSYNC}}$ and $\overline{\text{VSYNC}}$ pins for the color bars to be displayed. Given proper Slave Mode input timing or Master Mode, the color bar generator will override the video input pixel data.

The output of the color bar generator is instantiated after the chroma interpolation filter and before the luma delay line. The generated color bar numbers are for 100% amplitude, 100% saturation NTSC EIA color bars or 100% amplitude, 100% saturation PAL EBU color bars. For PAL color bars, the CS4954/5 generates NTSC color bar values, which are very close to standard PAL values. The exact luma and chroma values are listed in Table 6. .

Color	Cb	Cr	Y
White	0	0	+ 167
Yellow	- 84	+ 14	+ 156
Cyan	+ 28	- 84	+ 138
Green	- 56	- 70	+ 127
Magenta	+ 56	+ 70	+ 110
Red	- 28	+ 84	+ 99
Blue	+ 84	- 14	+ 81
Black	0	0	+ 70

Table 6. Internal Color Bar Values (8-bit values, Cb/Cr are in twos complement format)

5.13 VBI encoding

VBI (Vertical Blanking Interval) encoding is performed according to SMPTE RP 188 recommendations. In NTSC mode lines 10 - 20 and lines 272 - 283 are used for the transmission of ancillary data. In PAL mode lines 6 - 22 and lines 318 - 335 are used. The VBI encoding mode can be set through the CONTROL_3 register.

All digital input data is passed through the chip when this mode is enabled. It is therefore the responsibility of the user to ensure appropriate ampli-

tude levels. Table 7 shows the relationship of the digital input signal and the analog output voltage.

Digital Input	Analog Output Voltage
0×38	286 mV
0×3B	300 mV
0×C4	1000 mV

Table 7. VBI Encoding Signal Amplitudes

Each LSB corresponds to a step of 5 mV in the output voltage.

5.14 Super White/Super Black support

The ITU-R BT.601 recommendation limits the allowed range for the digital video data between 0×10 - 0×EB for luma and between 0×10 - 0×F0 for the chrominance values. This chip will clip any digital input value which is out of this range to conform to the ITU-R BT.601 specifications.

However for some applications it is useful to allow a wider input range. By setting the CLIP_OFF bit (CONTROL_6 register) the allowed input range is extended between 0×01 - 0×FE for both luma and chrominance values.

Note that 0×00 and 0×FF values are never allowed, since they are reserved for synchronization information.

5.15 Interrupts

In order to better support precise video mode switches and to establish a software/hardware handshake with the closed caption insertion block the CS4954/5 is equipped with an interrupt pin named INT. The INT pin is active high. There are three interrupt sources: $\overline{\text{VSYNC}}$, Line 21, and Line 284. Each interrupt can be individually disabled with the INT_EN Register. Each interrupt is also cleared via writing a one to the corresponding

INT_CLR Register bits. The three individual interrupts are OR-ed together to generate an interrupt signal which is presented on the INT output pin. If an interrupt has occurred, it cannot be eliminated with a disable, it must be cleared.

5.16 General Purpose I/O Port

The CS4954/5 has a GPIO port and register that is available when the device is configured for I²C host interface operation. In I²C host interface mode, the PDAT [7:0] pins are unused by the host interface and they can operate as input or output pins for the GPIO_DATA_REG Register (0×0A). The CS4954/5 also contains the GPIO_CTRL_REG Register (0×09) which is used to configure the GPIO pins for input or output operation.

The GPIO port PDAT [7:0] pins are configured for input operation when the corresponding GPIO_CTRL_REG [7:0] bits are set to 0. In GPIO input mode, the CS4954/5 will latch the data on the PDAT [7:0] pins into the corresponding bit locations of GPIO_DATA_REG when it detects register address 0×0A through the I²C interface. A detection of address 0×0A can happen in two ways. The first and most common way this will happen is when address 0×0A is written to the CS4954/5 via its I²C interface. The second method for detecting address 0×0A is implemented by accessing register address 0×09 through I²C. In I²C host interface operation, the CS4954/5 register address pointer will auto-increment to address 0×0A after an address 0×09 access.

The GPIO port PDAT [7:0] pins are configured for output operation when the corresponding GPIO_CTRL_REG [7:0] bits are set. In GPIO output mode, the CS4954/5 will output the data in GPIO_DATA_REG [7:0] bit locations onto the corresponding PDAT [7:0] pins when it detects a register address 0×0A through the I²C interface.

6. FILTER RESPONSES

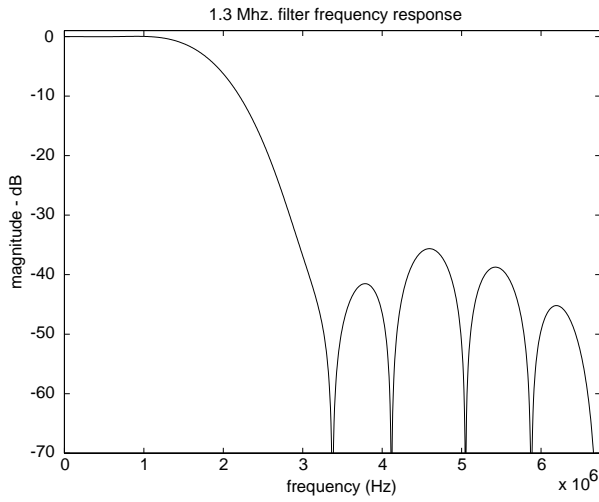

Figure 14. 1.3 Mhz Chrominance low-pass filter transfer characteristic

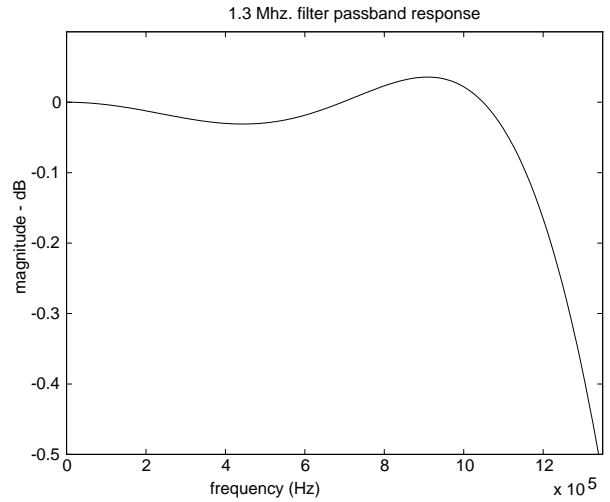

Figure 15. 1.3 Mhz Chrominance low-pass filter transfer characteristic (passband)

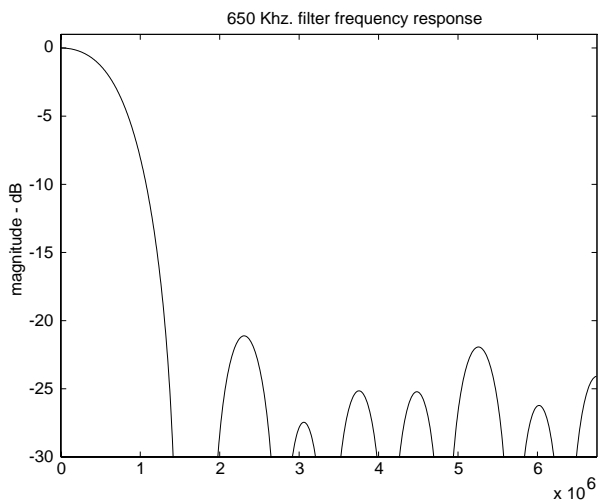

Figure 16. 650 kHz Chrominance low-pass filter transfer characteristic

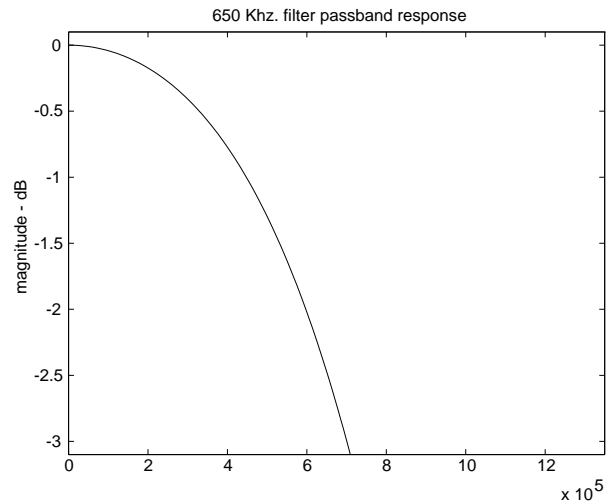

Figure 17. 650 kHz Chrominance low-pass filter transfer characteristic (passband)

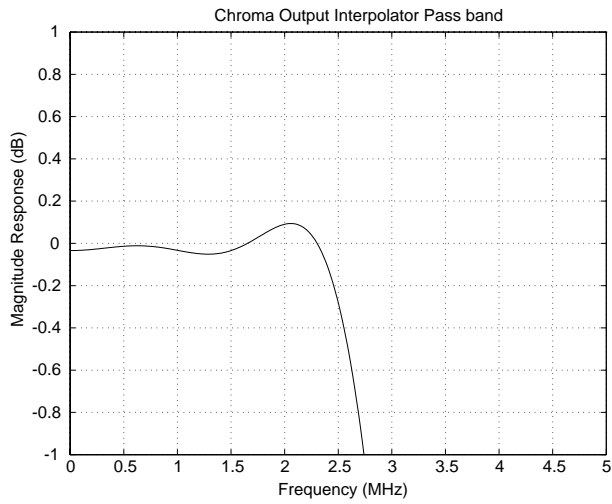

Figure 18. Chrominance output interpolation filter transfer characteristic (passband)

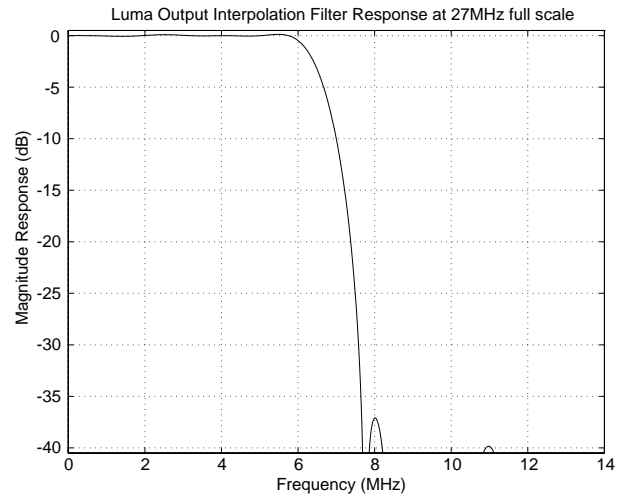

Figure 19. Luminance interpolation filter transfer characteristic

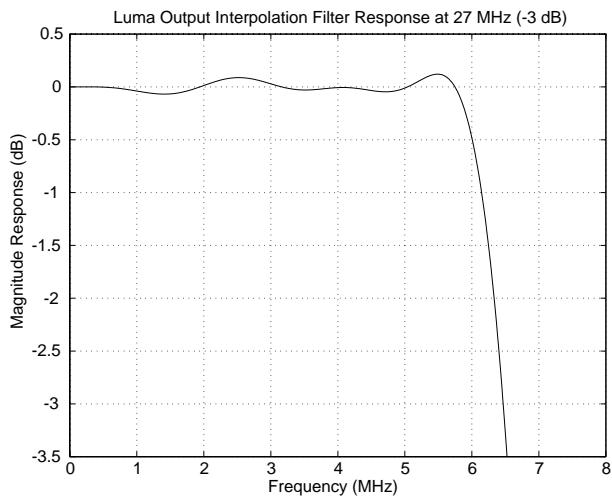

Figure 20. Luminance interpolation filter transfer characteristic (passband)

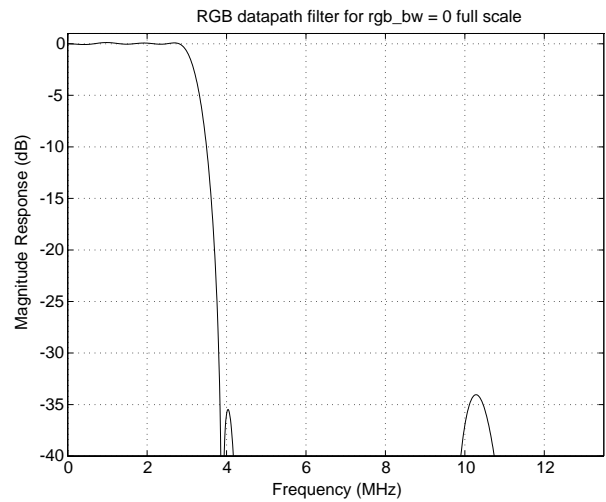

Figure 21. Chrominance interpolation filter transfer characteristic for RGB datapath

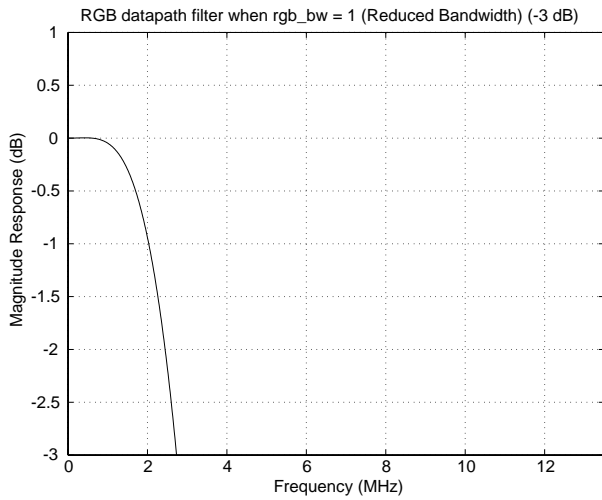

Figure 22. Chroma Interpolator for RGB Datapath when rgb_bw=1 (Reduced Bandwidth)

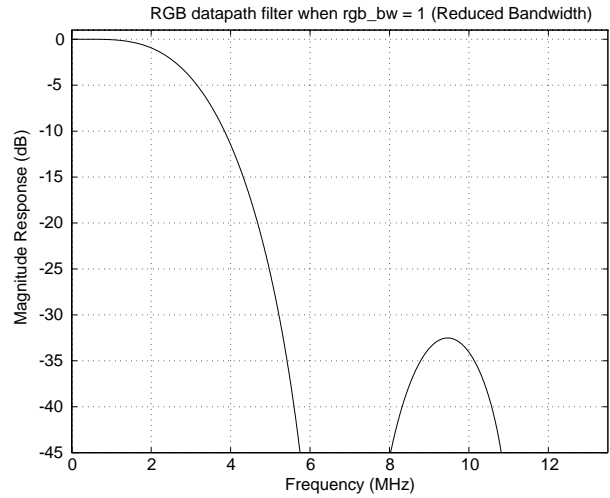

Figure 23. Chroma Interpolator for RGB Datapath when rgb_bw=1 (Reduced Bandwidth)

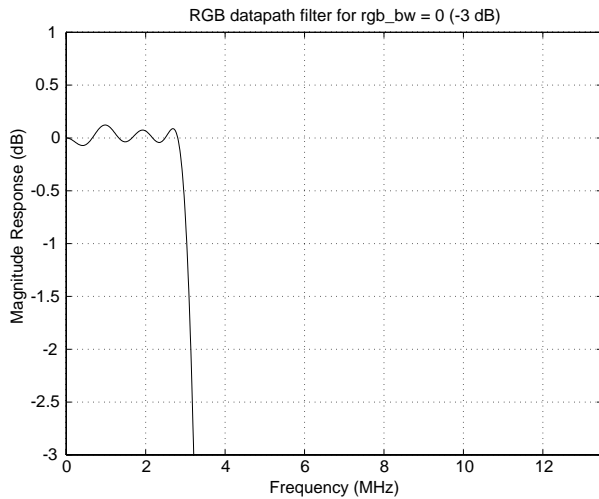

Figure 24. Chroma Interpolator for RGB Datapath when rgb_bw=0 -3 dB

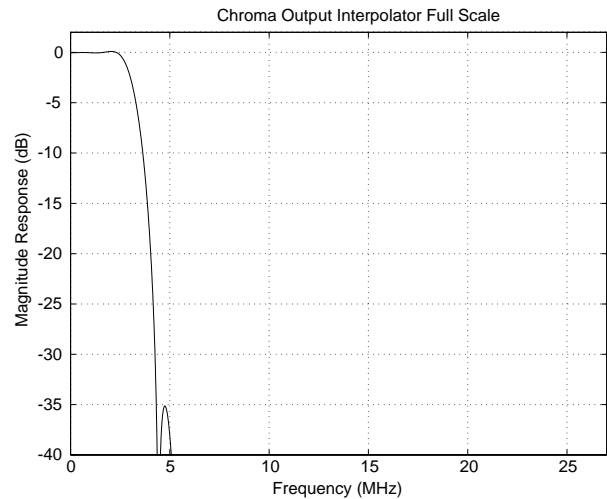

Figure 25. Chroma Interpolator for RGB Datapath when rgb_bw=0 (Full Scale)

7. ANALOG

7.1 Analog Timing

All CS4954/5 analog timing and sequencing is derived from 27 MHz clock input. The analog outputs are controlled internally by the video timing generator in conjunction with master and slave timing. The video output signals perform accordingly for NTSC and PAL specifications.

Being that the CS4954/5 is almost entirely a digital circuit, great care has been taken to guarantee analog timing and slew rate performance as specified in the NTSC and PAL analog specifications. Reference the Analog Parameters section of this data sheet for exact performance parameters.

7.2 VREF

The CS4954/5 can operate with or without the aid of an external voltage reference. The CS4954/5 is designed with an internal voltage reference generator that provides a VREFOUT signal at the VREF pin. The internal voltage reference is utilized by not making a connection to the VREF pin. The VREF pin can also be connected to an external precision 1.232 volt reference, which then overrides the internal reference.

7.3 ISET

All six of the CS4954/5 digital to analog converter DACs are output current normalized with a common ISET device pin. The DAC output current per bit is determined by the size of the resistor connected between ISET and electrical ground. Typically a 4 K Ω , 1% metal film resistor should be used. The ISET resistance can be changed by the user to accommodate varying video output attenuation via post filters and also to suit individual preferred performance.

In conjunction with the ISET value, the user can also independently vary the chroma, luma and colorburst amplitude levels via host addressable control register bits that are used to control internal

digital amplifiers. The DAC output levels are defined by the following operations:

$$\begin{aligned} V_{REF}/I_{SET} &= I_{REF} \\ (\text{e.g., } 1.232 \text{ V}/4\text{K } \Omega &= 308 \mu\text{A}) \end{aligned}$$

CVBS/Y/C/R/G/B outputs in low impedance mode:

$$V_{OUT}(\text{max}) = I_{REF} * (16/145) * 1023 * 37.5 \Omega = 1.304\text{V}$$

CVBS/Y/C/R/G/B outputs in high impedance mode:

$$V_{OUT}(\text{max}) = I_{REF} * (4/145) * 1023 * 150\Omega = 1.304 \text{ V}$$

7.4 DACs

The CS4954/5 is equipped with six independent, video-grade, current-output, digital-to-analog converters (DACs). They are 10-bit DACs operating at a 27 MHz two-times-oversampling rate. All six DACs are disabled and default to a low power mode upon RESET. Each DAC can be individually powered down and disabled. The output-current-per-bit of all six DACs is determined by the size of the resistor connected between the ISET pin and electrical ground.

7.4.1 Luminance DAC

The Y pin is driven from a 10-bit 27 MHz current output DAC that internally receives the Y, or luminance portion, of the video signal (black and white only). Y is designed to drive proper video levels into a 37.5 Ω load. Reference the detailed electrical section of this data sheet for the exact Y digital to analog AC and DC performance data. A EN_L enable control bit in the Control Register 5 (0x05) is provided to enable or disable the luminance DAC. For a complete disable and lower power operation the luminance DAC can be totally shut down via the SVIDLUM_PD control bit in the Control Register 4 (0x04). In this mode, turn-on through the control register will not be instantaneous.

7.4.2 Chrominance DAC

The C pin is driven from a 10-bit 27 MHz current output DAC that internally receives the C or

chrominance portion of the video signal (color only). C is designed to drive proper video levels into a 37.5 Ω load. Reference the detailed electrical section of this data sheet for the exact C digital to analog AC and DC performance data. A EN_C enable control register bit in the Control Register 1 (0x05) is provided to enable or disable the chrominance DAC. For a complete disable and lower power operation the chrominance DAC can be totally shut down via the SVIDCHR_PD register bit in the Control Register 4 (0x04). In this mode turn-on through the control register will not be instantaneous.

7.4.3 CVBS DAC

The CVBS pin is driven from a 10-bit 27 MHz current output DAC that internally receives a combined luma and chroma signal to provide composite video output. CVBS is designed to drive proper composite video levels into a 37.5 Ω load. Reference the detailed electrical section of this data sheet for the exact CVBS digital to analog AC and DC performance data. The EN_COM enable control register bit, in Control Register 1 (0x05), is provided to enable or disable the output pin. When disabled, there is no current flow from the output. For a complete disable and lower power operation, the CVBS37 DAC can be totally shut down via the COMDAC_PD control register bit in Control Register 4 (0x04). In this mode turn-on through the control register will not be instantaneous.

7.4.4 Red DAC

The Red pin is driven from a 10-bit 27 MHz current output DAC that internally receives a combined luma and chroma signal to provide composite video output. Red is designed to drive proper composite video levels into a 37.5 Ω load. Reference the detailed electrical section of this data sheet for the exact red digital to analog AC and DC performance data. The EN_R enable control register bit, in Control Register 1 (0x05), is provided to enable or disable the output pin. When disabled, there is no

current flow from the output. For a complete disable and lower power operation, the red DAC can be totally shut down via the R_PD control register bit in Control Register 4 (0x04). In this mode turn-on through the control register will not be instantaneous.

7.4.5 Green DAC

The green pin is driven from a 10-bit 27 MHz current output DAC that internally receives a combined luma and chroma signal to provide composite video output. Green is designed to drive proper composite video levels into a 37.5 Ω load. Reference the detailed electrical section of this data sheet for the exact green digital to analog AC and DC performance data. The EN_G enable control register bit, in Control Register 1 (0x05), is provided to enable or disable the output pin. When disabled, there is no current flow from the output. For a complete disable and lower power operation, the green DAC can be totally shut down via the G_PD control register bit in Control Register 4 (0x04). In this mode turn-on through the control register will not be instantaneous.

7.4.6 Blue DAC

The blue pin is driven from a 10-bit 27 MHz current output DAC that internally receives a combined luma and chroma signal to provide composite video output. Blue is designed to drive proper composite video levels into a 37.5 Ω load. Reference the detailed electrical section of this data sheet for the exact blue digital to analog AC and DC performance data. The EN_B enable control register bit, in Control Register 5 (0x05), is provided to enable or disable the output pin. When disabled, there is no current flow from the output. For a complete disable and lower power operation, the blue DAC can be totally shut down via the B_PD control register bit in Control Register 4 (0x04). In this mode turn-on through the control register will not be instantaneous.

If some of the 6 DACs are not used, it is strongly recommended to power them down (see CONTROL_4 register) in order to reduce the power dissipation.

Depending on the external resistor connected to the ISET pin the output drive of the DACs can be changed. There are two modes in which the DACs should either be operated in. An external resistor of 4 kΩ must be connected to the ISET pin.

The first mode is the high impedance mode (LOW_IMP bit set to 0). The DAC outputs will then drive a double terminated load of 300 Ω and will output a video signal which conforms to the analog video specifications for NTSC and PAL. External buffers will be needed if the DAC output load differs from 300 Ω.

The second mode is the low impedance mode (LOW_IMP bit set to 1). The DAC output will then drive a double terminated load of 75 Ω and will output a video signal which conforms to the analog video specifications for NTSC and PAL. No external buffers are necessary, the outputs can directly drive a television input.

Note that for power dissipation purposes it is not always possible to have all the 6 DACs active at the same time. Table 8 shows the maximum allowed active DACs depending on the power supply and low/high impedance modes. If less than 6 DACs are allowed to be active the other ones **must** be power down (see CONTROL_4 register).

Nominal Power supply	Low/High Impedance mode	maximum # of active DACs
3.3V	Low Impedance	3
3.3V	High Impedance	6
5.0V	Low Impedance	3
5.0V	High Impedance	6

Table 8. Maximum DAC Numbers

8. PROGRAMMING

8.1 Host Control Interface

The CS4954/5 host control interface can be configured for I²C or 8-bit parallel operation. The CS4954/5 will default to I²C operation when the \overline{RD} and \overline{WR} pins are both tied low at power up. The \overline{RD} and \overline{WR} pins are active for 8-bit parallel operation only.

8.1.1 I²C Interface

The CS4954/5 provides an I²C interface for accessing the internal control and status registers. External pins are a bidirectional data pin (SDA) and a serial input clock (SCL). The protocol follows the I²C specifications. A complete data transfer is shown in Figure 26. Note that this I²C interface will work in Slave Mode only - it is not a bus master.

SDA and SCL are connected via an external pull-up resistor to a positive supply voltage. When the bus is free, both lines are high. The output stages of devices connected to the bus must have an open-drain or open-collector in order to perform the

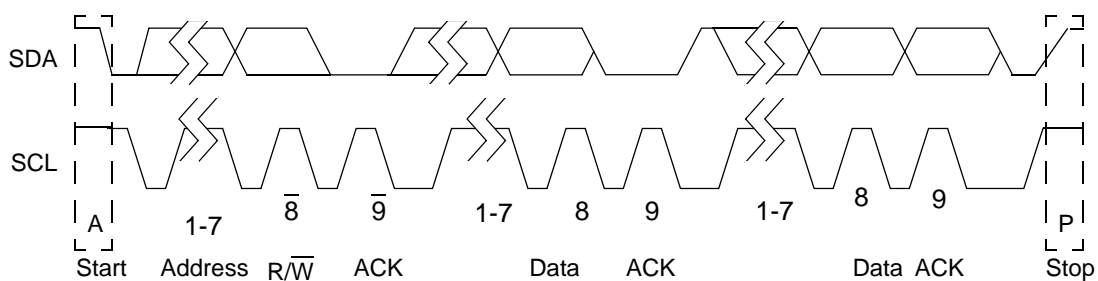

Note: I²C transfers data always with MSB first, LSB last

Figure 26. I²C Protocol

wired-AND function. Data on the I²C bus can be transferred at a rate of up to 400 Kbits/sec in fast mode. The number of interfaces to the bus is solely dependent on the limiting bus capacitance of 400 pF. When 8-bit parallel interface operation is being used, SDA and SCL can be tied directly to ground.

The I²C bus address for the CS4954/5 is programmable via the I2C_ADR Register (0x0F). When I²C interface operation is being used, \overline{RD} and \overline{WR} must be tied to ground. PDAT [7:0] are available to be used for GPIO operation in I²C host interface mode. For 3.3 V operation it is necessary to have the appropriate level shifting for I²C signals.

8.1.2 8-bit Parallel Interface

The CS4954/5 is equipped with a full 8-bit parallel microprocessor write and read control port. Along with the PDAT [7:0] pins, the control port interface

is comprised of host read (\overline{RD}) and host write (\overline{WR}) active low strobes and host address enable (ADDR), which, when low, enables unique address register accesses. The control port is used to access internal registers which configure the CS4954/5 for various modes of operation. The internal registers are uniquely addressed via an address register. The address register is accessed during a host write cycle with the \overline{WR} and ADDR pins set low. Host write cycles with ADDR set high will write the 8-bits on the PDAT [7:0] pins into the register currently selected by the address register. Likewise read cycles occurring with \overline{RD} set low and ADDR set high will return the register contents selected by the address register. Reference the detailed electrical timing parameter section of this data sheet for exact host parallel interface timing characteristics and specifications.

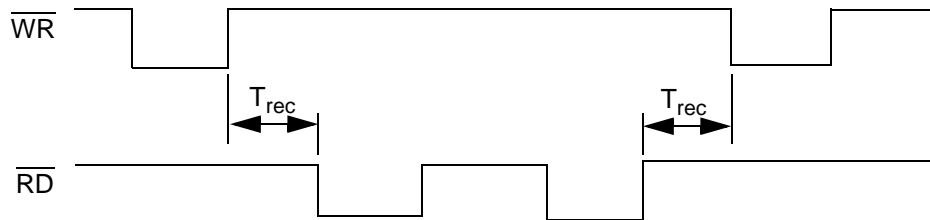

Figure 27. 8-bit Parallel Host Port Timing: Read-Write/Write-Read Cycle

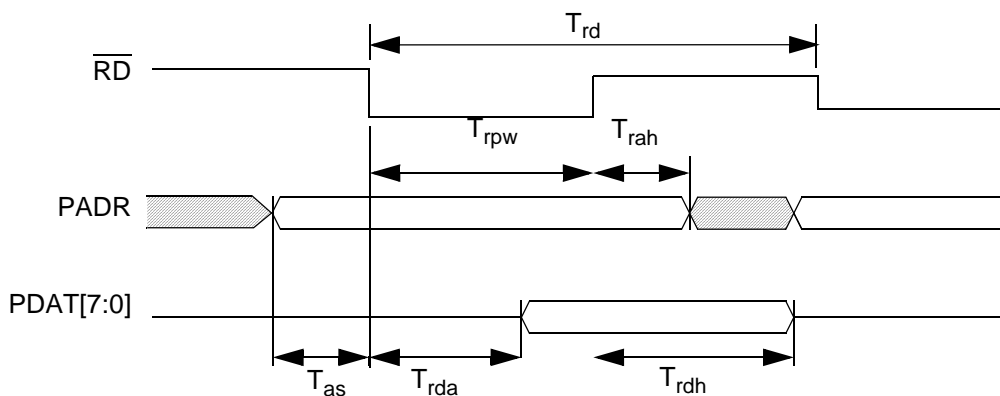

Figure 28. 8-bit Parallel Host Port Timing: Address Read Cycle

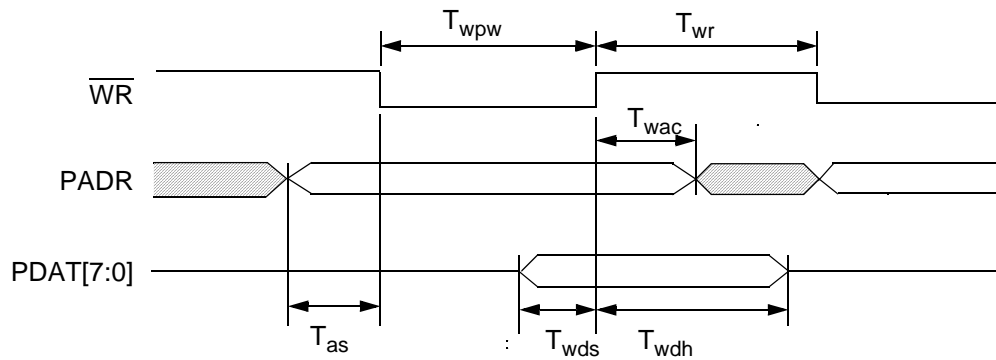

Figure 29. 8-bit Parallel Host Port Timing: Address Write Cycle

8.2 Register Description

A set of internal registers are available for controlling the operation of the CS4954/5. The registers extend from internal address 0×00 through 0×5A. Table 9 shows a complete list of these registers and their internal addresses. Note that this table and the

subsequent register description section describe the full register map for the CS4954 only. A complete CS4955 register set description is available only to Macrovision ACP-PPV Licensed Buyers.

8.2.1 Control Registers

Address	Register Name	Type	Default value
0×00	control_0	r/w	01h
0×01	control_1	r/w	02h
0×02	control_2	r/w	00h
0×03	control_3	r/w	00h
0×04	control_4	r/w	3Fh
0×05	control_5	r/w	00h
0×06	control_6	r/w	00h
0×07	RESERVED		
0×08	bkg_color	r/w	03h
0×09	gpio_ctrl_reg	r/w	00h
0×0A	gpio_data_reg	r/w	00h
0×0B	RESERVED		
0×0C	RESERVED		
0×0D	SYNC_0	r/w	90h
0×0E	SYNC_1	r/w	F4h
0×0F	I ² C_ADR	r/w	00h
0×10	SC_AMP	r/w	1Ch
0×11	SC_SYNTH0	r/w	3Eh
0×12	SC_SYNTH1	r/w	F8h
0×13	SC_SYNTH2	r/w	E0h
0×14	SC_SYNTH3	r/w	43h
0×15	HUE_LSB	r/w	00h
0×16	HUE_MSB	r/w	00h

Table 9. Control Registers

Address	Register Name	Type	Default value
0x17	SCH PHASE ADJUST	r/w	00h
0x18	CC_EN	r/w	00h
0x19	CC_21_1	r/w	00h
0x1A	CC_21_2	r/w	00h
0x1B	CC_284_1	r/w	00h
0x1C	CC_284_2	r/w	00h
0x1D	RESERVED		
0x1E	WSS_REG_0	r/w	00h
0x1F	WSS_REG_1	r/w	00h
0x20	WSS_REG_2	r/w	00h
0x21	RESERVED		
0x22	CB_AMP	r/w	80h
0x23	CR_AMP	r/w	80h
0x24	Y_AMP	r/w	80h
0x25	R_AMP	r/w	80h
0x26	G_AMP	r/w	80h
0x27	B_AMP	r/w	80h
0x28	BRIGHT_OFFSET	r/w	00h
0x29	TTXHS	r/w	A1h
0x2A	TTXHD	r/w	02h
0x2B	TTXOVS	r/w	00h
0x2C	TTXOVE	r/w	00h
0x2D	TTXEVS	r/w	00h
0x2E	TTXEVE	r/w	00h
0x2F	TTX_DIS1	r/w	00h
0x30	TTX_DIS2	r/w	00h
0x31	TTX_DIS_3	r/w	00h
0x32	INT_EN	r/w	00h
0x33	INT_CLR	r/w	00h
0x34	STATUS_0	read only	
0x35 - 0x59	RESERVED		
0x5A	STATUS_1	read only	04h
0x61 - 0x7F	RESERVED		

Table 9. Control Registers (Continued)

Control Register 0

Address 0x00 CONTROL_0 Read/Write Default Value = 01h

Bit Number	7	6	5	4	3	2	1	0
Bit Name	TV_FMT			MSTR	CCIR656	PROG	IN_MODE	CBCR_UV
Default	0	0	0	0	0	0	0	1

Bit	Mnemonic	Function
7:5	TV_FMT	selects the TV display format 000: NTSC-M CCIR601 timing (default) 001: NTSC-M RS170A timing 010: PAL-B, D, G, H, I 011: PAL-M 100: PAL-N (Argentina) 101: PAL-N (non Argentina) 110-111: reserved
4	MSTR	1 = Master Mode, 0 = Slave Mode
3	CCIR656	video input is in ITU R.BT656 format (0 = off, 1 = on)
2	PROG	Progressive scanning enable (enable = 1)
1	IN_MODE	Input select (0 = solid background, 1 = use V [7:0] data)
0	CBCR_UV	enable YCbCr to YUV conversion (1 = enable, 0 = disable)

Control Register 1

Address 0x01 CONTROL_1 Read/Write Default Value = 02h

Bit Number	7	6	5	4	3	2	1	0
Bit Name	LUM_DEL		CH_BW	LPF_ON	RGB_BW	FLD	PED	CBCRSEL
Default	0	0	0	0	0	0	1	0

Bit	Mnemonic	Function
7:6	LUM_DEL	luma delay on the composite1 output 00: no delay (default) 01: 1 pixel clock delay 10: 2 pixel clock delay 11: 3 pixel clock delay
5	CH_BW	chroma lpf bandwidth (0 = 650 kHz, 1 = 1.3 Mhz)
4	LPF_ON	chroma lpf on/off (0 = off, 1 = on)
3	RGB_BW	0 = Full bandwidth on RGB, 1 = BW reduced to 2.5 MHz (3 dB point) (default 0)
2	FLD_POL	Polarity of Field (0: odd field = 0, 1: odd field = 1)
1	PED	Pedestal offset (0: 0 IRE, 1: 7.5 IRE)
0	CBCRSEL	CbCr select (0 = chroma undelayed, 1 = chroma delayed by one clock)

Control Register 2

Address 0x02 CONTROL_2 Read/Write Default Value = 00h

Bit Number	7	6	5	4	3	2	1	0
Bit Name	OUTPUT_FORMAT			TTX_WST	TTX_EN	SYNC_DLY	XTAL	SC_EN
Default	0	0	0	0	0	0	0	0

Bit	Mnemonic	Function
7:5	OUTPUT_FORMAT	selects the output through the DACs 000 : rgb, s-video, composite1 (6 DACs) (default) 001 : yuv, s-video, composite1 (6 DACs) 010 : s-video, composite1, composite2, (4 DACs) 011 : rgb, composite1, composite2 (5 DACs) 100 : yuv, composite1, composite2 (5 DACs) 101-111: don't care
4	TTX_WST	To select between world standard (NTSC), world standard (PAL), or north american teletext standard during NTSC or PAL modes (1 = WST TTX) (default is 0) In NTSC-M or PAL-M mode. This bit works in conjunction with the TV_FORMAT register. 0: NABTS, if TV_FORMAT is NTSC or PAL-M 1: WST (NTSC), if TV_FORMAT is NTSC or PAL-M 0: Europe TTX, if TV_FORMAT is PAL-B, G..., N 1: WST (PAL), if TV_FORMAT is PAL-B, G, ..., N
3	TTX_EN	Enable teletext process (1 = enable)
2	SYNC_DLY	Slave mode 1 pixel sync delay (1 = enable)
1	XTAL	Crystal oscillator for subcarrier adjustment enable (1 = enable)
0	BU_DIS	Chroma burst disable (1 = disable)

Control Register 3

Address 0x03 CONTROL_3 Read/Write Default Value = 00h

Bit Number	7	6	5	4	3	2	1	0
Bit Name	RESERVED			FD_THR_C1	FD_THR_C2	FD_THR_SV	FD_THR_EN	CBAR
Default	0	0	0	0	0	0	0	0

Bit	Mnemonic	Function
7:5	-	reserved
4	FD_THR_C1	feedthrough enabled for composite_1 output (0 = off, 1 = on)
3	FD_THR_C2	feedthrough enabled for composite_2 output (0 = off, 1 = on)
2	FD_THR_SV	feedthrough enabled for s-video (on luma signal) (0 = off, 1 = on)
1	FD_THR_EN	Enable (1 = enable) input to feed through during inactive lines
0	CBAR	internal color bar generator (0 = off, 1 = on)

Control Register 4

Address 0x04 CONTROL_4 Read/Write Default Value = 3Fh

Bit Number	7	6	5	4	3	2	1	0
Bit Name	CB_H_SEL	CB_FLD_SEL ⁽¹⁾	COMDAC_PD	SVIDLUM_PD	SVIDCHR_PD	R_PD	G_PD	B_PD
Default	0	0	1	1	1	1	1	1

Bit	Mnemonic	Function
7	CB_H_SEL	Composite Blank / HSYNC output select (1 = CB select, 0 = HSYNC select)
6	CB_FLD_SEL	Composite Blank / FIELD output select (1 = CB select, 0 = FIELD select) ⁽¹⁾
5	COMDAC_PD	power down composite DAC 0: power up, 1: power down
4	SVIDLUM_PD	power down luma s-video DAC 0: power up, 1: power down
3	SVIDCHR_PD	power down chroma s-video DAC 0: power up, 1: power down
2	R_PD	power down red rgb video DAC 0: power up, 1: power down
1	G_PD	power down green rgb video DAC 0: power up, 1: power down
0	B_PD	power down blue rgb video DAC 0: power up, 1: power down

NOTE: 1. The FIELD pin (pin 9) remains an output pin in SLAVE mode. However, the FIELD pin state does not toggle in SLAVE mode and its output state should be considered random.

Control Register 5

Address 0x05 CONTROL_5 Read/Write Default Value = 00h

Bit Number	7	6	5	4	3	2	1	0
Bit Name	RSVD	LOW_IMP	EN_COM	EN_L	EN_C	EN_R	EN_G	EN_B
Default	0	0	0	0	0	0	0	0

Bit	Mnemonic	Function
7	-	reserved
6	LOW_IMP	selects between high output impedance (0) or low output impedance (1) mode of DACs
5	EN_COM	enable DAC for composite output 0: high-impedance, 1: enable
4	EN_L	enable S-VIDEO DAC for luma output 0: high-impedance, 1: enable
3	EN_C	enable S-VIDEO DAC for chroma output 0: high-impedance, 1: enable
2	EN_R	enable RGB video DAC for red output 0: high-impedance, 1: enable
1	EN_G	enable RGB video DAC for green output 0: high-impedance, 1: enable
0	EN_B	enable RGB video DAC for blue output 0: high-impedance, 1: enable

Control Register 6

Address 0x06 CONTROL_6 Read/Write Default Value = 00h

Bit Number	7	6	5	4	3	2	1	0
Bit Name	656_SYNC_OUT	CLIP_OFF	TTXEN_COM2	TTXEN_COM1	TTXEN_SVID	BSYNC_DIS	GSYNC_DIS	RSYNC_DIS
Default	0	0	0	0	0	0	0	0

Bit	Mnemonic	Function
7	656_SYNC_OUT	Enable (=1) output of hsync and vsync in the ITU R.BT656 mode
6	CLIP_OFF	Clipping input signals disable (0: clipping active 1: no clipping)
5	TTXEN_COM2	Enable teletext at the composit2 output (0: disable teletext, 1 : enable teletext)
4	TTXEN_COM1	Enable teletext at the composit1 output (0: disable teletext, 1 : enable teletext)
3	TTXEN_SVID	Enable teletext at the s-video output (0: disable teletext, 1: enable teletext)
2	BSYNC_DIS	Disable syncs in the blue or v output (0: enable syncs, 1: disable syncs)
1	GSYNC_DIS	Disable syncs in the green or u output (0: enable syncs, 1: disable syncs)
0	RSYNC_DIS	Disable syncs in the red or y output (0: enable syncs, 1: disable syncs)

Background Color Register

Address 0×08 BKG_COLOR Read/Write Default Value = 03h

Bit Number	7	6	5	4	3	2	1	0
Bit Name	BG							
Default	0	0	0	0	0	0	1	1

Bit	Mnemonic	Function
7:0	BG	Background color (7:5 = R, 4:2 = G, 1:0 = B) (default is 0000 0011 - blue)

GPIO Control Register

Address 0×09 GPIO_REG Read/Write Default Value = 00h

Bit Number	7	6	5	4	3	2	1	0
Bit Name	GPR_CNTRL							
Default	0	0	0	0	0	0	0	0

Bit	Mnemonic	Function
7:0	GPR_CNTRL	Input(0)/output(1) control of GPIO registers (bit 0: PDAT(0), bit 7: PDAT(7))

GPIO Data Register

Address 0×0A GPIO_REG Read/Write Default Value = 00h

Bit Number	7	6	5	4	3	2	1	0
Bit Name	GPIO_REG							
Default	0	0	0	0	0	0	0	0

Bit	Mnemonic	Function
7:0	GPIO_REG	GPIO data register (data is output on PDAT bus if appropriate bit in address 09 is set to "1", otherwise data is input/output through I ² C)- This register is only accessible in I ² C mode.

Sync Register 0

Address 0×0D Sync_0 Read/Write Default Value = 90h

Bit Number	7	6	5	4	3	2	1	0
Bit Name	PROG_VS[4:0]				PROG_HS[10:8]			
Default	1	0	0	1	0	0	0	0

Bit	Mnemonic	Function
7:3	PROG_VS[4:0]	programmable vsync lines
2:0	PROG_HS[10:8]	programmable hsync pixels (3 most significant bits)

Sync Register 1

Address	0×0E	Sync_1	Read/Write	Default Value = F4h				
Bit Number	7	6	5	4	3	2	1	0
Bit Name	PROG_HS[7:0]							
Default	1	1	1	1	0	1	0	0

Bit	Mnemonic	Function
7:0	PROG_HS[7:0]	programmable hsync pixels lsb

I²C Address Register

Address	0×0F	I ² C_ADR	Read/Write	Default Value = 00h				
Bit Number	7	6	5	4	3	2	1	0
Bit Name	RESERVED	I ² C_ADR						
Default	0	0	0	0	0	0	0	0

Bit	Mnemonic	Function
7	-	reserved
6:0	I ² C	I ² C device address (programmable)

Subcarrier Amplitude Register

Address	0×10	SC_AMP	Read/Write	Default Value = 1Ch				
Bit Number	7	6	5	4	3	2	1	0
Bit Name	BU_AMP							
Default	0	0	0	1	1	1	0	0

Bit	Mnemonic	Function
7:0	BU_AMP	Color burst amplitude

Subcarrier Synthesis Register

Address	0×11	SC_SYNTH0	Read/Write	Default Value = 3Eh
	0×12	SC_SYNTH1		F8h
	0×13	SC_SYNTH2		E0h
	0×14	SC_SYNTH3		43h

Register	Bits	Mnemonic	Function
SC_SYNTH0	7:0	CC_0	Subcarrier synthesis bits 7:0
SC_SYNTH1	7:0	CC_1	Subcarrier synthesis bits 15:8
SC_SYNTH2	7:0	CC_2	Subcarrier synthesis bits 23:16
SC_SYNTH3	7:0	CC_3	Subcarrier synthesis bits 31:24

Hue LSB Adjust Register

Address 0×15 HUE_LSB Read/Write Default Value = 00h

Bit Number	7	6	5	4	3	2	1	0
Bit Name	HUE_LSB							
Default	0	0	0	0	0	0	0	0

Bit	Mnemonic	Function
7:0	HUE_LSB	8 LSBs for hue phase shift

Hue MSB Adjust Register

Address 0×16 HUE_MSB Read/Write Default Value = 00h

Bit Number	7	6	5	4	3	2	1	0
Bit Name	RESERVED						MSB	
Default	0	0	0	0	0	0	0	0

Bit	Mnemonic	Function
7:2	-	reserved
1:0	HUE_MSB	2 MSBs for hue phase shift

SCH Sync Phase Adjust

Address 0×17 SCH Read/Write Default Value = 00h

Bit	Mnemonic	Function
7:0	SCH	Default - 00h in increments of ≈1.4 degree per bit up to 360°

Closed Caption Enable Register

Address 0×18 CC_EN Read/Write Default Value = 00h

Bit Number	7	6	5	4	3	2	1	0
Bit Name	RESERVED						EN_284	EN_21
Default	0	0	0	0	0	0	0	0

Bit	Mnemonic	Function
7:2	-	reserved
1	CC_EN[1]	enable closed caption for line 284
0	CC_EN[0]	enable closed caption for line 21

Closed Caption Data Register

Address	0×19	CC_21_1	Read/Write	Default Value = 00h
	0×1A	CC_21_2		00h
	0×1B	CC_284_1		00h
	0×1C	CC_284_2		00h

Bit	Mnemonic	Function
7:0	CC_21_1	first closed caption databyte of line 21
7:0	CC_21_2	second closed caption databyte of line 21
7:0	CC_284_1	first closed caption databyte of line 284
7:0	CC_284_2	second closed caption databyte of line 284

Wide Screen Signaling Register 0

Address	0×1E	WSS_REG_0	Read/Write	Default Value = 00h
---------	------	-----------	------------	---------------------

Bit Number	7	6	5	4	3	2	1	0
Bit Name	WSS_23	WSS_22	WSS_21	WSS_20	WSS_19	WSS_18	WSS_17	WSS_16
Default	0	0	0	0	0	0	0	0

Bit	Mnemonic	Function
7	WSS_23	Enable wide screen signalling (enable =1)
6	WSS_22	PAL: enable WSS (enable = 1) on line 23 of field 2, NTSC: don't care
5	WSS_21	PAL: group 4, bit 13, NTSC: don't care
4	WSS_20	PAL: group 4, bit 12, NTSC: don't care
3	WSS_19	PAL: group 4, bit 11, NTSC: bit 20
2	WSS_18	PAL: group 3, bit 10, NTSC: bit 19
1	WSS_17	PAL: group 3, bit 9, NTSC: bit 18
0	WSS_16	PAL: group 3, bit 8, NTSC: bit 17

Wide Screen Signalling Register 1

Address 0x1F WSS_REG_1 Read/Write Default Value = 00h

Bit Number	7	6	5	4	3	2	1	0
Bit Name	WSS_15	WSS_14	WSS_13	WSS_12	WSS_11	WSS_10	WSS_9	WSS_8
Default	0	0	0	0	0	0	0	0

Bit	Mnemonic	Function
7	WSS_15	PAL: group 2, bit 7, NTSC: bit 16
6	WSS_14	PAL: group 2, bit 6, NTSC: bit 15
5	WSS_13	PAL: group 2, bit 5, NTSC: bit 14
4	WSS_12	PAL: group 2, bit 4, NTSC: bit 13
3	WSS_11	PAL: group 1, bit 3, NTSC: bit 12
2	WSS_10	PAL: group 1, bit 2, NTSC: bit 11
1	WSS_9	PAL: group 1, bit 1, NTSC: bit 10
0	WSS_8	PAL: group 1, bit 0, NTSC: bit 9

Wide Screen Signalling Register 2

Address 0x20 WSS_REG_2 Read/Write Default Value = 00h

Bit Number	7	6	5	4	3	2	1	0
Bit Name	WSS_7	WSS_6	WSS_5	WSS_4	WSS_3	WSS_2	WSS_1	WSS_0
Default	0	0	0	0	0	0	0	0

Bit	Mnemonic	Function
7	WSS_7	PAL: don't care, NTSC: bit 8
6	WSS_6	PAL: don't care, NTSC: bit 7
5	WSS_5	PAL: don't care, NTSC: bit 6
4	WSS_4	PAL: don't care, NTSC: bit 5
3	WSS_3	PAL: don't care, NTSC: bit 4
2	WSS_2	PAL: don't care, NTSC: bit 3
1	WSS_1	PAL: don't care, NTSC: bit 2
0	WSS_0	PAL: don't care, NTSC: bit 1

Filter Register 0

Address 0x22 CB_AMP Read/Write Default Value = 80h

Bit Number	7	6	5	4	3	2	1	0
Bit Name	U_AMP							
Default	1	0	0	0	0	0	0	0

Bit	Mnemonic	Function
7:0	U_AMP	U(Cb) amplitude coefficient

Filter Register 1

Address 0x23 CR_AMP Read/Write Default Value = 80h

Bit Number	7	6	5	4	3	2	1	0
Bit Name	V_AMP							
Default	1	0	0	0	0	0	0	0

Bit	Mnemonic	Function
7:0	V_AMP	V(Cr) amplitude coefficient

Filter Register 2

Address 0x24 Y_AMP Read/Write Default Value = 80h

Bit Number	7	6	5	4	3	2	1	0
Bit Name	Y_AMP							
Default	1	0	0	0	0	0	0	0

Bit	Mnemonic	Function
7:0	Y_AMP	Luma amplitude coefficient

Filter Register 3

Address 0x25 R_AMP Read/Write Default Value = 80h

Bit Number	7	6	5	4	3	2	1	0
Bit Name	R_AMP							
Default	1	0	0	0	0	0	0	0

Bit	Mnemonic	Function
7:0	R_AMP	Red amplitude coefficient

Filter Register 4

Address 0x26 G_AMP Read/Write Default Value = 80h

Bit Number	7	6	5	4	3	2	1	0
Bit Name	G_AMP							
Default	1	0	0	0	0	0	0	0

Bit	Mnemonic	Function
7:0	G_AMP	Green amplitude coefficient

Filter Register 5

Address 0x27 B_AMP Read/Write Default Value = 80h

Bit Number	7	6	5	4	3	2	1	0
Bit Name	B_AMP							
Default	1	0	0	0	0	0	0	0

Bit	Mnemonic	Function
7:0	B_AMP	Blue amplitude coefficient

Filter Register 6

Address 0x28 Bright_Offsett Read/Write Default Value = 00h

Bit Number	7	6	5	4	3	2	1	0
Bit Name	BRIGHTNESS_OFFSET							
Default	0	0	0	0	0	0	0	0

Bit	Mnemonic	Function
7:0	BRGHT_OFFSET	Brightness adjustment (range: -128 to +127)

Teletext Register 0

Address 0x29 TTXHS Read/Write Default Value = A1h

Bit Number	7	6	5	4	3	2	1	0
Bit Name	TTXHS							
Default	1	0	1	0	0	0	0	1

Bit	Mnemonic	Function
7:0	TTXHS	Start of teletext request pulses or start of window

Teletext Register 1

Address 0x2A TTXHD Read/Write Default Value = 02h

Bit Number	7	6	5	4	3	2	1	0
Bit Name	TTXHD							
Default	0	0	0	0	0	0	1	0

Bit	Mnemonic	Function
7:0	TTXHD	<p>If TTX_WINDOW = 0 then this register is used as the Pipeline delay between TTXRQ and TTXDAT signal in the teletext source. User programmable delay step of 37 ns per LSB.</p> <p>If TTX_WINDOW = 1 then this register is used as the 8 LSBs of the teletext insertion windows; the 3 MSBs are located in register 0x31. (register 0x31 bit 3)</p>

Teletext Register 2

Address 0×2B TTXOVS Read/Write Default Value = 00h

Bit Number	7	6	5	4	3	2	1	0
Bit Name	TTXOVS							
Default	0	0	0	0	0	0	0	0

Bit	Mnemonic	Function
7:0	TTXOVS	Start of teletext line window in odd field

Teletext Register 3

Address 0×2C TTXOVE Read/Write Default Value = 00h

Bit Number	7	6	5	4	3	2	1	0
Bit Name	TTXOVE							
Default	0	0	0	0	0	0	0	0

Bit	Mnemonic	Function
7:0	TTXOVE	End of teletext line window in odd field

Teletext Register 4

Address 0×2D TTXEVS Read/Write Default Value = 00h

Bit Number	7	6	5	4	3	2	1	0
Bit Name	TTXEVS							
Default	0	0	0	0	0	0	0	0

Bit	Mnemonic	Function
7:0	TTXEVS	Start of teletext line window in even field

Teletext Register 5

Address 0×2E TTXEVE Read/Write Default Value = 00h

Bit Number	7	6	5	4	3	2	1	0
Bit Name	TTXEVE							
Default	0	0	0	0	0	0	0	0

Bit	Mnemonic	Function
7:0	TTXEVE	End of teletext line window in even field

Teletext Register 6

Address 0x2F TTX_DIS1 Read/Write Default Value = 00h

Bit Number	7	6	5	4	3	2	1	0
Bit Name	TTX_LINE_DIS1							
Default	0	0	0	0	0	0	0	0

Bit	Mnemonic	Function
7:0	TTX_LINE_DIS1	Teletext disable bits corresponding to the lines 5-12 respectively, (11111111=all eight lines are disabled), (MSB is for line 5, LSB is for line 12)

Teletext Register 7

Address 0x30 TTX_DIS2 Read/Write Default Value = 00h

Bit Number	7	6	5	4	3	2	1	0
Bit Name	TTX_LINE_DIS2							
Default	0	0	0	0	0	0	0	0

Bit	Mnemonic	Function
7:0	TTX_LINE_DIS2	Teletext disable bits corresponding to the lines 13-20 respectively, (11111111=all eight lines are disabled), (MSB is for line 13, LSB is for line 20)

Teletext Register 8

Address 0x31 TTX_DIS3 Read/Write Default Value = 00h

Bit Number	7	6	5	4	3	2	1	0
Bit Name	TTXHD			RESERVED	TTX_WINDOW	TTX_LINE_DIS3		
Default	0	0	0	0	0	0	0	0

Bit	Mnemonic	Function
7:5	TTXHD	If TTX_WINDOW = 0 these 3 bits are unused. If TTX_WINDOW = 1 these 3 bits are the MSBs of the register 0x2A; they are used to specify the length of the teletext insertion window
4	Reserved	
3	TTX_WINDOW	Selects between TTXRQ (= 0) pulsation or TTXRQ (= 1) Window mode
2:0	TTX_LINE_DIS3	Teletext disable bits corresponding to the lines 13-20 respectively, (111=all three lines are disabled), (MSB is for line 21, LSB is for line 23)

Interrupt Register 0

Address 0x32 INT_EN Read/Write Default Value = 00h

Bit Number	7	6	5	4	3	2	1	0
Bit Name	RESERVED					INT_21_EN	INT_284_EN	INT_V_EN
Default	0	0	0	0	0	0	0	0

Bit	Mnemonic	Function
7:3	-	reserved
2	INT_21_EN	interrupt enable for closed caption line 21
1	INT_284_EN	interrupt enable for closed caption line 284
0	INT_V_EN	interrupt enable for new video field

Interrupt Register 1

Address 0x33 INT_CLR Read/Write Default Value = 00h

Bit Number	7	6	5	4	3	2	1	0
Bit Name	RESERVED					CLR_INT_21	CLR_INT_284	CLR_INT_V
Default	0	0	0	0	0	0	0	0

Bit	Mnemonic	Function
7:3	-	reserved
2	CLR_INT_21	clear interrupt for closed caption line 21 (INT 21)
1	CLR_INT_284	clear interrupt for closed caption line 284 (INT_284)
0	CLR_INT_V	clear interrupt for new video field (INT_V)

Status Register 0

Address 0x34 STATUS_0 Read Only Default Value = 00h

Bit Number	5	4	3	2:0
Bit Name	INT_21	INT_284	INT_V	FLD
Default	0	0	0	0

Bit	Mnemonic	Function
5	INT_21	Interrupt flag for line 21 (closed caption) complete
4	INT_284	Interrupt flag for line 284 (closed caption) complete
3	INT_V	Interrupt flag for video field change
2:0	FLD_ST	Field Status bits(001 = field 1,000 = field 8)

Status Register 1

Address 0x5A STATUS_1 Read only Default Value = 04h

Bit Number	7	6	5	4	3	2	1	0
Bit Name	DEVICE_ID							
Default	0	0	0	0	0	1	0	0

Bit	Mnemonic	Function
7:0	DEVICE_ID	Device identification: CS4954: 0000 0100, CS4955: 0000 0101

9. BOARD DESIGN AND LAYOUT CONSIDERATIONS

The printed circuit layout should be optimized for lowest noise on the CS4954/5 placed as close to the output connectors as possible. All analog supply traces should be as short as possible to minimize inductive ringing.

A well designed power distribution network is essential in eliminating digital switching noise. The ground planes must provide a low-impedance return path for the digital circuits. A PC board with a minimum of four layers is recommended. The ground layer should be used as a shield to isolate noise from the analog traces. The top layer (1) should be reserved for analog traces but digital traces can share this layer if the digital signals have low edge rates and switch little current or if they are separated from the analog traces by a significant distance (dependent on their frequency content and current). The second layer should then be the ground plane followed by the analog power plane on layer three and the digital signal layer on layer four.

9.1 Power and Ground Planes

The power and ground planes need isolation gaps of at least 0.05" to minimize digital switching noise effects on the analog signals and components. A split analog/digital ground plane should be connected at one point as close as possible to the CS4954/5.

9.2 Power Supply Decoupling

Start by reducing power supply ripple and wiring harness inductance by placing a large (33-100 uF) capacitor as close to the power entry point as possible. Use separate power planes or traces for the digital and analog sections even if they use the same supply. If necessary, further isolate the digital and analog power supplies by using ferrite beads on each supply branch followed by a low ESR capacitor.

Place all decoupling caps as close as possible to the device as possible. Surface mount capacitors generally have lower inductance than radial lead or axial lead components. Surface mount caps should be placed on the component side of the PCB to minimize inductance caused by board vias. Any vias, especially to ground, should be as large as possible to reduce their inductive effects.

9.3 Digital Interconnect

The digital inputs and outputs of the CS4954/5 should be isolated from the analog outputs as much as possible. Use separate signal layers whenever possible and do not route digital signals over the analog power and ground planes.

Noise from the digital section is related to the digital edge rates used. Ringing, overshoot, undershoot, and ground bounce are all related to edge rate. Use lower speed logic such as HCMOS for the host port interface to reduce switching noise. For the video input ports, higher speed logic is required, but use the slowest practical edge rate to reduce noise. To reduce noise, it is important to match the source impedance, line impedance, and load impedance as much as possible. Generally, if the line length is greater than one fourth the signal edge rate, line termination is necessary. Ringing can also be reduced by damping the line with a series resistor (22-150 Ω). Under extreme cases, it may be advisable to use microstrip techniques to further reduce radiated switching noise if very fast edge rates (<2ns) are used. If microstrip techniques are used, split the analog and digital ground planes and use proper RF decoupling techniques.

9.4 Analog Interconnect

The CS4954/5 should be located as close as possible to the output connectors to minimize noise pickup and reflections due to impedance mismatch. All unused analog outputs should be placed in shutdown. This reduces the total power that the CS4954/5 requires, and eliminates the impedance mismatch

presented by an unused connector. The analog outputs should not overlay the analog power plane to maximize high frequency power supply rejection.

9.5 Analog Output Protection

To minimize the possibility of damage to the analog output sections, make sure that all video connectors are well grounded. The connector should have a good DC ground path to the analog and digital power supply grounds. If no DC (and low frequency) path is present, improperly grounded equipment can impose damaging reverse currents on the video out lines. Therefore, it is also a good

idea to use output filters that are AC coupled to avoid any problems.

9.6 ESD Protection

All MOS devices are sensitive to Electro Static Discharge (ESD). When manipulating these devices, proper ESD precautions are recommended to avoid performance degradation or permanent damage.

9.7 External DAC Output Filter

If an output filter is required, the low pass filter shown in Figure 30 can be used.

NOTE:

C_2 should be chosen so that $C_1 = C_2 + C_{\text{cable}}$

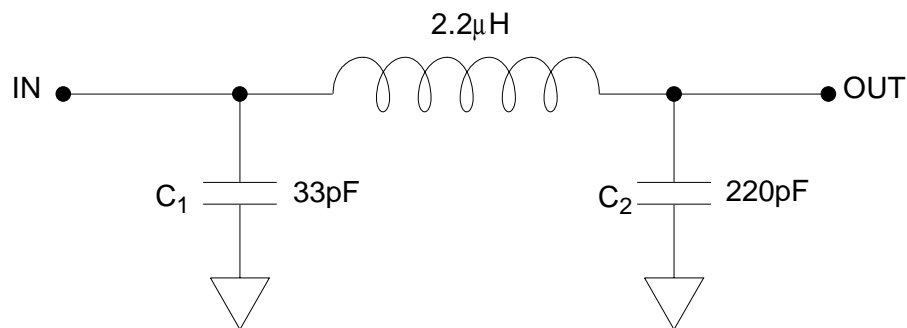

Figure 30. External Low Pass Filter

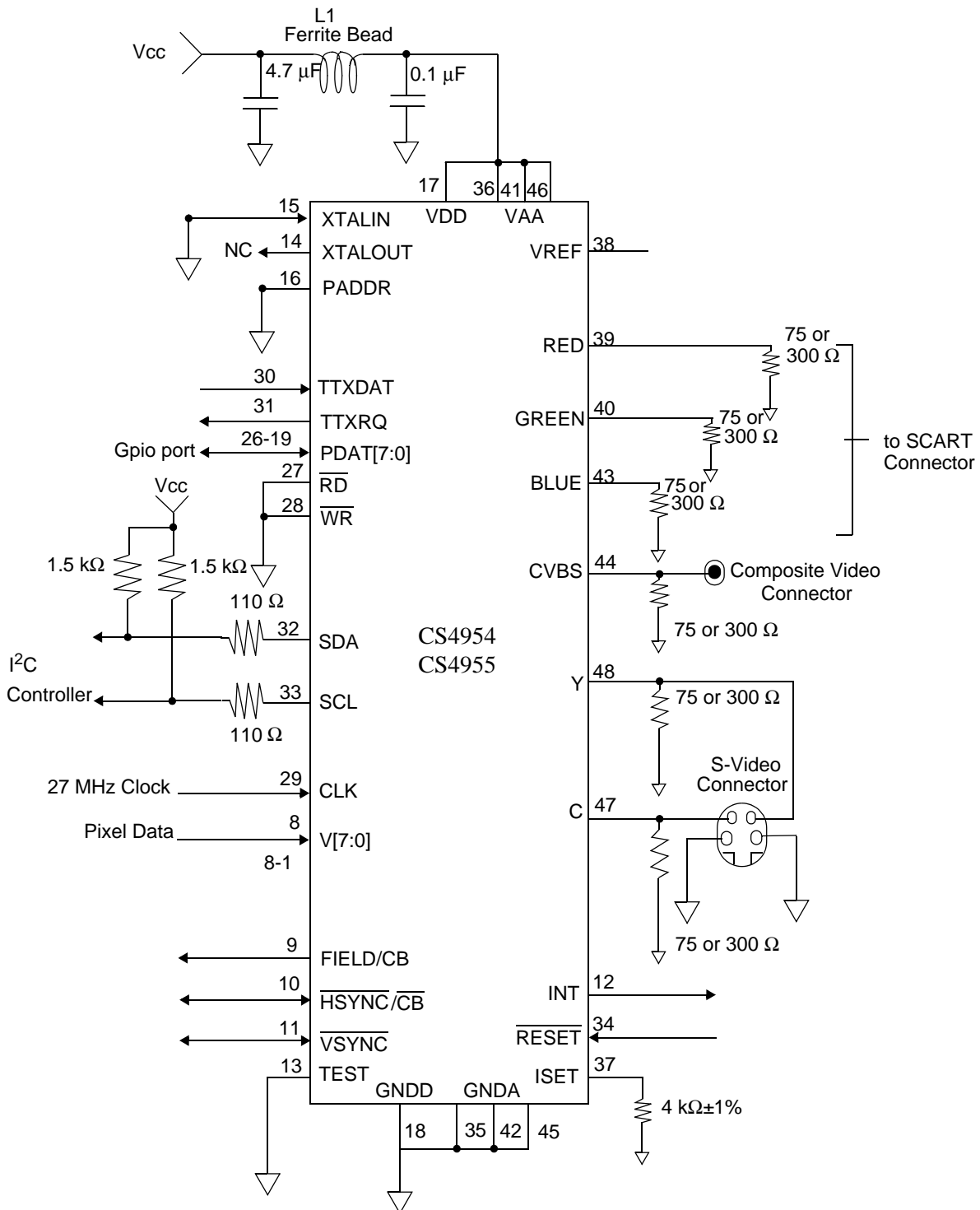
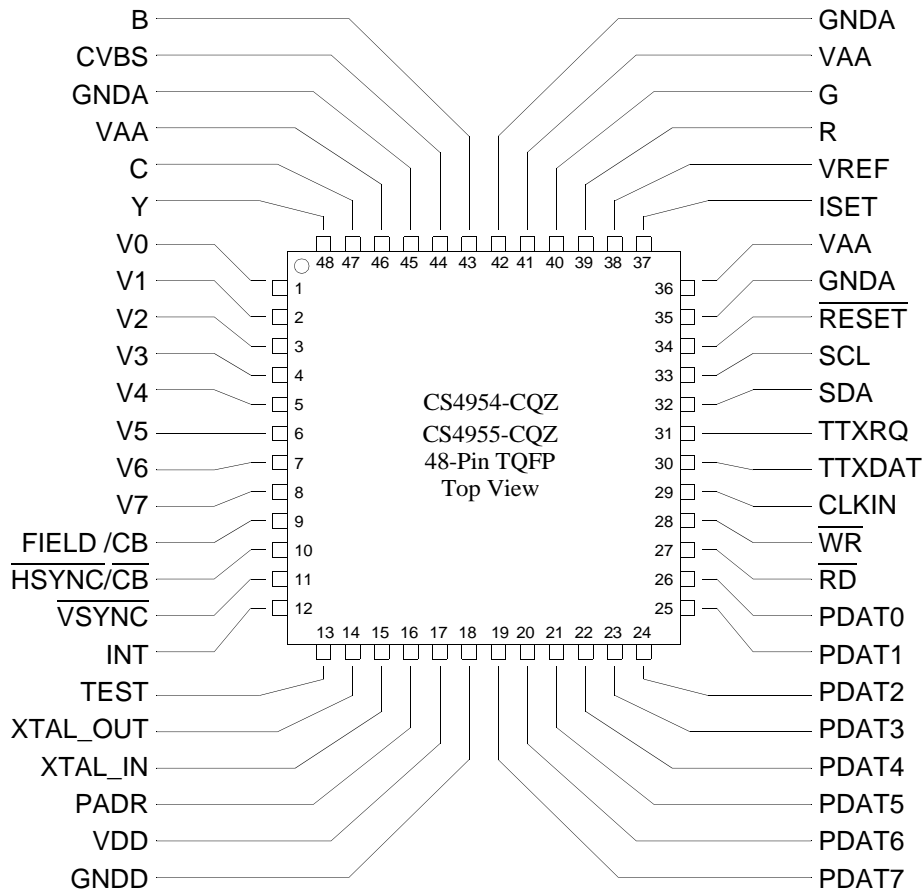

Figure 31. Typical Connection Diagram

10. PIN DESCRIPTION

Pin Name	Pin Number	Type	Description
V [7:0]	8, 7, 6, 5, 4, 3, 2, 1	IN	Digital video data inputs
CLK	29	IN	27 MHz input clock
PADDR	16	IN	Address enable line
XTAL_IN	15	IN	subcarrier crystal input
XTAL_OUT	14	OUT	subcarrier crystal output
HSYNC/CB	10	I/O	Active low horizontal sync, or composite blank signal
VSYNC	11	I/O	Active low vertical sync.
FIELD/CB ⁽¹⁾	9	OUT ⁽¹⁾	Video field ID. Selectable polarity or composite blank
RD	27	IN	Host parallel port read strobe, active low
WR	28	IN	Host parallel port write strobe, active low
PDAT [7:0]	19, 20, 21, 22, 23, 24, 25, 26	I/O	Host parallel port/ general purpose I/O
SDA	32	I/O	I ² C data
SCL	33	IN	I ² C clock input
CVBS	44	CURRENT	Composite video output
Y	48	CURRENT	Luminance analog output
C	47	CURRENT	Chrominance analog output
R	39	CURRENT	Red analog output
G	40	CURRENT	Green analog output
B	43	CURRENT	Blue analog output
VREF	38	I/O	Internal voltage reference output or external reference input
ISET	37	CURRENT	DAC current set
TTXDAT	30	IN	Teletext data input
TTXRQ	31	OUT	Teletext request output
INT	12	OUT	Interrupt output, active high
RESET	34	IN	Active low master RESET
TEST	13	IN	TEST pin. Ground for normal operation
VAA	36, 41, 46	PS	+ 5 V or + 3.3 V supply (must be same as VDD)
GNDD	18	PS	Ground
VDD	17	PS	+5 V or 3.3 V supply (must be same as VAA)
GNDA	35, 42, 45	PS	Ground

Table 10. Device Pin Descriptions

NOTE: 1. The FIELD pin (pin 9) remains an output pin in SLAVE mode. However, the FIELD pin state does not toggle in SLAVE mode and its output state should be considered random.

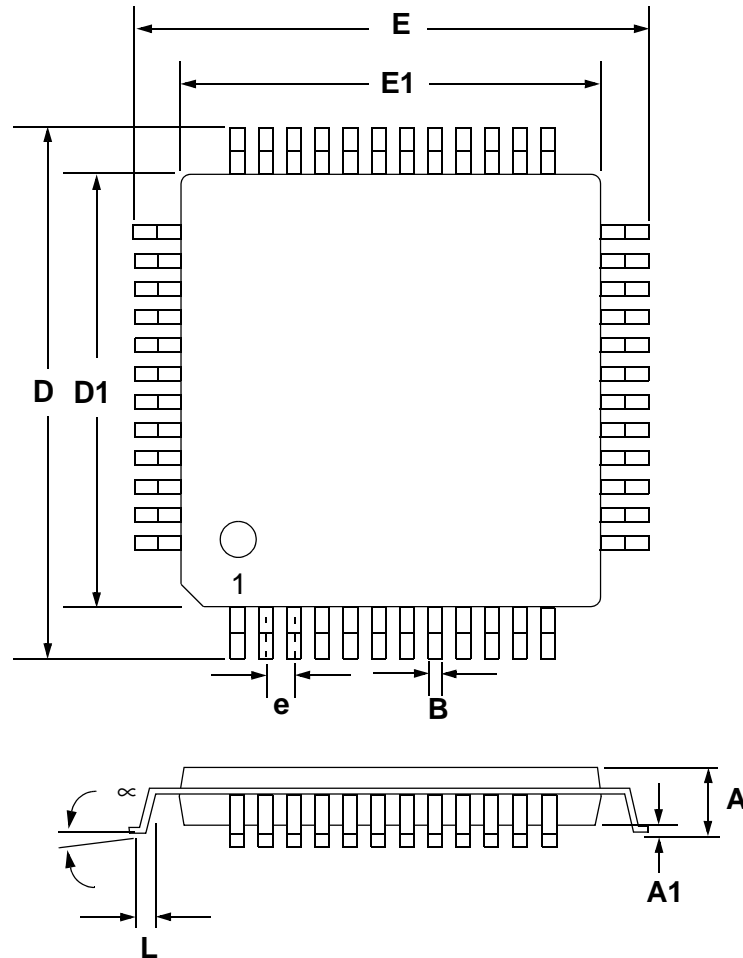
11. PACKAGE DRAWING
48L TQFP PACKAGE DRAWING

DIM	INCHES		MILLIMETERS	
	MIN	MAX	MIN	MAX
A	---	0.063	---	1.60
A1	0.002	0.006	0.05	0.15
B	0.007	0.011	0.17	0.27
D	0.343	0.366	8.70	9.30
D1	0.272	0.280	6.90	7.10
E	0.343	0.366	8.70	9.30
E1	0.272	0.280	6.90	7.10
e*	0.016	0.024	0.40	0.60
L	0.018	0.030	0.45	0.75
∞	0.000°	7.000°	0.00°	7.00°

* Nominal pin pitch is 0.50 mm

Controlling dimension is mm.
JEDEC Designation: MS026

12. REVISION HISTORY

Revision	Date	Change
F1	July 1999	Initial release
F2	April 2004	Corrected List of Figures
F3	September 2004	Added lead free package option (CS4955).
F4	August 2005	Updated ordering information. Added lead-free package for CS4954; deleted CQ packages; updated Revision History and Legal notice.

Contacting Cirrus Logic Support

For all product questions and inquiries contact a Cirrus Logic Sales Representative.

To find the one nearest to you go to www.cirrus.com

IMPORTANT NOTICE

Cirrus Logic, Inc. and its subsidiaries ("Cirrus") believe that the information contained in this document is accurate and reliable. However, the information is subject to change without notice and is provided "AS IS" without warranty of any kind (express or implied). Customers are advised to obtain the latest version of relevant information to verify, before placing orders, that information being relied on is current and complete. All products are sold subject to the terms and conditions of sale supplied at the time of order acknowledgment, including those pertaining to warranty, indemnification, and limitation of liability. No responsibility is assumed by Cirrus for the use of this information, including use of this information as the basis for manufacture or sale of any items, or for infringement of patents or other rights of third parties. This document is the property of Cirrus and by furnishing this information, Cirrus grants no license, express or implied under any patents, mask work rights, copyrights, trademarks, trade secrets or other intellectual property rights. Cirrus owns the copyrights associated with the information contained herein and gives consent for copies to be made of the information only for use within your organization with respect to Cirrus integrated circuits or other products of Cirrus. This consent does not extend to other copying such as copying for general distribution, advertising or promotional purposes, or for creating any work for resale.

CERTAIN APPLICATIONS USING SEMICONDUCTOR PRODUCTS MAY INVOLVE POTENTIAL RISKS OF DEATH, PERSONAL INJURY, OR SEVERE PROPERTY OR ENVIRONMENTAL DAMAGE ("CRITICAL APPLICATIONS"). CIRRUS PRODUCTS ARE NOT DESIGNED, AUTHORIZED OR WARRANTED FOR USE IN AIRCRAFT SYSTEMS, MILITARY APPLICATIONS, PRODUCTS SURGICALLY IMPLANTED INTO THE BODY, AUTOMOTIVE SAFETY OR SECURITY DEVICES, LIFE SUPPORT PRODUCTS OR OTHER CRITICAL APPLICATIONS. INCLUSION OF CIRRUS PRODUCTS IN SUCH APPLICATIONS IS UNDERSTOOD TO BE FULLY AT THE CUSTOMER'S RISK AND CIRRUS DISCLAIMS AND MAKES NO WARRANTY, EXPRESS, STATUTORY OR IMPLIED, INCLUDING THE IMPLIED WARRANTIES OF MERCHANTABILITY AND FITNESS FOR PARTICULAR PURPOSE, WITH REGARD TO ANY CIRRUS PRODUCT THAT IS USED IN SUCH A MANNER. IF THE CUSTOMER OR CUSTOMER'S CUSTOMER USES OR PERMITS THE USE OF CIRRUS PRODUCTS IN CRITICAL APPLICATIONS, CUSTOMER AGREES, BY SUCH USE, TO FULLY INDEMNIFY CIRRUS, ITS OFFICERS, DIRECTORS, EMPLOYEES, DISTRIBUTORS AND OTHER AGENTS FROM ANY AND ALL LIABILITY, INCLUDING ATTORNEYS' FEES AND COSTS, THAT MAY RESULT FROM OR ARISE IN CONNECTION WITH THESE USES.

Cirrus Logic, Cirrus, and the Cirrus Logic logo designs are trademarks of Cirrus Logic, Inc. All other brand and product names in this document may be trademarks or service marks of their respective owners.

I²C is a registered trademark of Philips Semiconductor.

Macrovision is a trademark of Macrovision Corporation. It is hereby notified that a third-party license from Macrovision Corporation is necessary to distribute software of Macrovision Corporation in any finished end-user or ready-to-use final product.