

VACUUM FLUORESCENT GRAPHIC
DISPLAY MODULE
SPECIFICATION

MODEL : GU256X64 - 355

SPECIFICATION NO. : DS-263-0000-00
DATE OF ISSUE : Feb. 8, 1992
NO. OF PRESENTATION :
REVISION :

PUBLISHED BY :
ISE ELECTRONICS CORP. / JAPAN

1. Scope

This specification covers the requirements of vacuum fluorescent graphic display module.
Model : GU256X64-355

2. General Description

The module consists of a graphic VFD which is having the dot configuration of 64X256, drivers, a refresh RAM, a character generator, a DC/DC converter, a display controller and all necessary control logics.

The module can display graphic patterns and/or characters in a screen of the VFD.

3. Absolute Maximum Ratings

parameter	Symbol	Abs. Max
Power Supply Volt.	VCC	+5.5V
Logic Supply Volt.	VIN	+7.0V

4. Electrical Rating

Parameter	Symbol	Min.	Typ.	Max.	Unit
Power Supply Volt.	VCC	4.75	5.0	5.25	V

All driving voltages for the VFD are converted from the DC/DC converter on the board.

5. Electrical Characteristics

Parameter	Symbol	Min.	Typ.	Max.	Unit	Condition	Note	
Input Logic Voltage	H	V _{IH}	2.2	-	VCC	V	VCC=5.0V	
	L	V _{IL}	-	-	0.8	V	VCC=5.0V	
Output Logic Voltage	H	V _{OH}	4.2	-	-	V	I _{OH} =-40μA	
	L	V _{OL}	-	-	0.5	V	I _{OL} =1.6mA	
Power Sup. Curr. 1	ICC 1	-	1.7	1.9	A	VCC=5.0V	(1)	
Power Sup. Curr. 2	ICC 2	-	1.4	1.6	A	VCC=5.0V	(2)	

Note (1), (2) ICC 1 shows the current at all dots in the screen are lighted and ICC 2 at all dots off. At power on rush, more than 2 times current of above table should be expected. Provide the power supply which has current capacity of approximate 5 Amps and also quick rise type (<100 msec.).

6. Optical Ratings

Display Area (X x Y)	: 166.25 x 41.45 mm
Number of dots (X x Y)	: 256 x 64
Dot Size (X x Y)	: 0.45 x 0.5 mm
Dot Pitch (center to center)	: 0.65 mm
Luminance	: 630 cd/m ² (180 fL) Typ.
Illuminating Color	: Blue green

7. Environmental Conditions

Operating Temperature	: 0 to +50°C
Storage Temperature	: -20 to +70°C
Operating Humidity	: 20 to 80 % R.H (Non condensed)
Vibration	: 10 to 55 Hz, 10 G max, 3 direction, 30 min. each
Shock	: 40 G, 9 msec

8. Functions of Data Lines

Data Line	Function
D0 ~ D7	Data Bus (Input/Output)
\overline{WR}	Write Signal (Input)
\overline{RD}	Read Signal (Input)
\overline{CS}	Chip Select Signal (Input)
C/\overline{D}	Command/Data Select Signal (Input) C/ \overline{D} = "1" ... Command C/ \overline{D} = "0" ... Data
FRP	Frame Signal (Output) (1 output pulse per 1 display frame)
\overline{BL}	Display Blanking Signal (Input)

9. Construction and Major Functions

The module consists of 1 PC board of drivers, control logics and power supply.

The display memory (RAM) has the capacity of 8k bytes and it can be memorized 4 screen pages at graphic mode and 8 screen pages at character mode. (See para.12)

The display screens can be alternatable as the screen #1 for graphic only and the screen #2 for character and graphic. Therefore, 4 different display combinations are available as follows.

- Graphic display only (use the screen #1 or #2)
- Character display only (use the screen #2)
- 2 graphic displays such as OR/EX-OR/AND (use the screen #1 and #2)
- Graphic (use the screen #1) and Character (use the screen #2) displays such as OR/EX-OR/AND

The display pattern data can be written/read to/from the graphic screen and the display character code can be written/read to/from the character screen using data bus.

A character is consisted of 6 x 8 dot.

Since display start address can be set independently at both the screen #1 and #2, scrolling or page rolling might be also available independently.

Within the graphic screen, left and right scroll by 1 line (1 dot) unit is doable and the character screen can be able the upper and lower scroll by 1 column (8 dots) unit.

9.1 Block Diagram

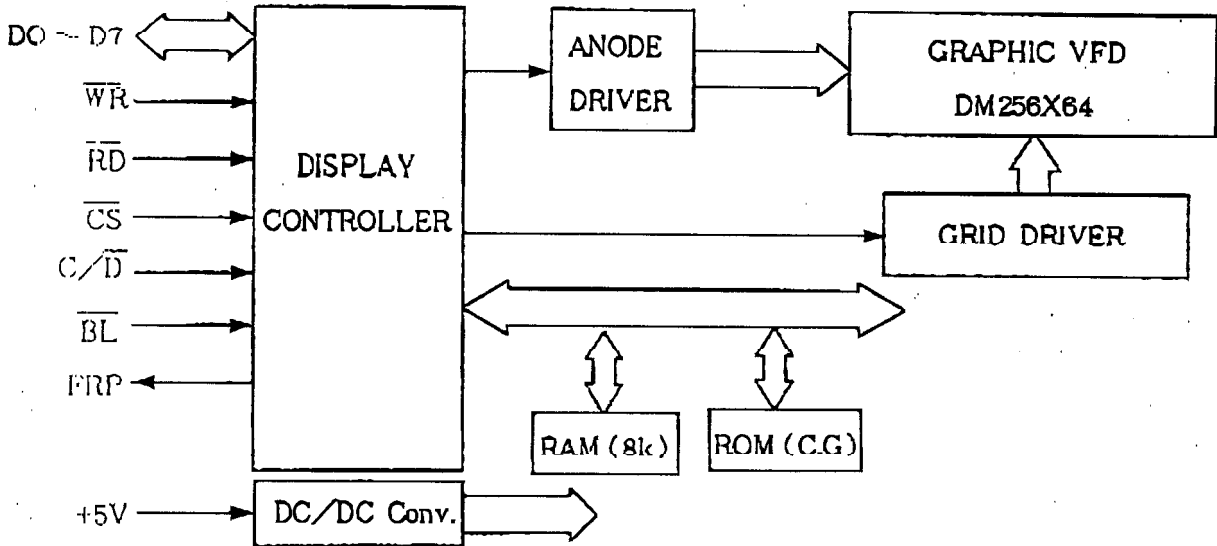

9.2 The Relationship of Display Memory and Command

(XXH* show the commands which will be described hereafter)

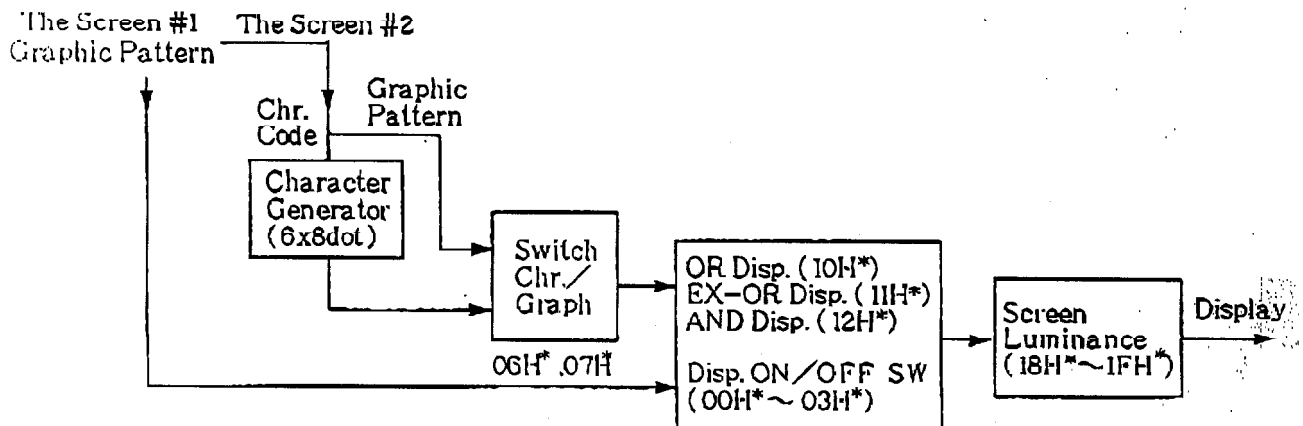
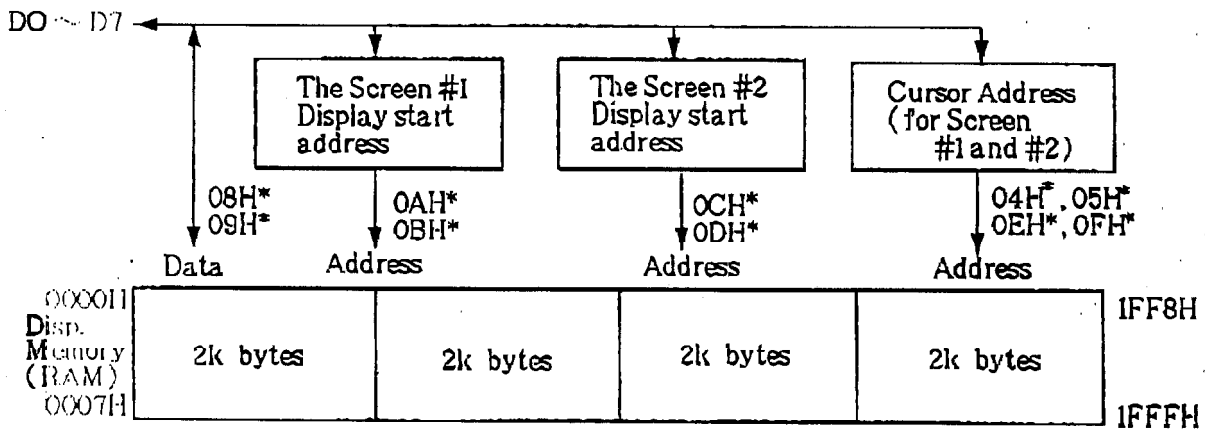

10. Commands

Command Table: Following table shows all commands and brief description of functions.

Command (C/D="1")					Setting Data (C/D="0")								Function
D4	D3	D2	D1	D0	D7	D6	D5	D4	D3	D2	D1	D0	
0	0	0	0	0									Both Screen #1 & #2 are OFF
0	0	0	0	1									Only Screen #1 is ON
0	0	0	1	0									Only Screen #2 is ON
0	0	0	1	1									Both #1 & #2 are ON
0	0	1	0	0									Cursor increments automatically
0	0	1	0	1									Cursor holds
0	0	1	1	0									Screen #2 sets to "Character" disp
0	0	1	1	1									Screen #2 sets to "Graphic" disp
0	1	0	0	0	X	X	X	X	X	X	X	X	Data write mode
0	1	0	0	1	X	X	X	X	X	X	X	X	Data read mode
0	1	0	1	0	A7-----							A0	Lower adrs of disp start of #1
0	1	0	1	1	X	X	X	A12-----				A8	Upper adrs of disp start of #1
0	1	1	0	0	A7-----							A0	Lower adrs of disp start of #2
0	1	1	0	1	X	X	X	A12-----				A8	Upper adrs of disp start of #2
0	1	1	1	0	A7-----							A0	Lower adrs of cursor of #1 & #2
0	1	1	1	1	X	X	X	A12-----				A8	Upper adrs of cursor or #1 & #2
1	0	0	0	0									OR Display of Screen #1 & #2
1	0	0	0	1									EX-OR Display of Screen #1 & #2
1	0	0	1	0									AND Display of Screen #1 & #2
1	1	X	X	X									Screen Luminance Control

The term "Cursor" means the writing or reading position.

10.1 Screen Control

10.1.1 Screen ON/OFF Control

Command (C/D="1")					Function	Default Selection
D4	D3	D2	D1	D0		
0	0	0	0	0	Both Screen #1 & #2 are OFF	X
0	0	0	0	1	Only Screen #1 is ON	
0	0	0	1	0	Only Screen #2 is ON	
0	0	0	1	1	Both Screen #1 & #2 are ON	

The latest command is only valid from above table.

At power on, Screen #1 and #2 are set to OFF. Therefore, appropriate ON command should be input after written of pattern data or character codes.

10.1.2 OR/EX-OR/AND Display (Screen Merge)

Command (C/D="1")					Function	Default Selection
D4	D3	D2	D1	D0		
1	0	0	0	0	OR display of Screen #1 & #2	X
1	0	0	0	1	EX-OR display of Screen #1 & #2	
1	0	0	1	0	AND display of screen #1 & #2	

The latest command is only valid from above table.

These commands are only effective when both screen #1 & #2 are selected (03H).

If only one screen is selected, that screen is displayed without merge.

10.2 Automatic Increment/Hold of Cursor Address

Command (C/D="1")					Function	Default Selection
D4	D3	D2	D1	D0		
0	0	1	0	0	Cursor address is incremented automatically	X
0	0	1	0	1	Cursor address is holded	

The cursor address which will be executed after Data Write or Data Read can be set to automatic INCREMENT or HOLD by above commands.

The cursor address will be incremented one address count on the address map covering all RAM area.

10.3 Character/Graphic Display

Command (C/D="1")					Function	Default Selection
D4	D3	D2	D1	D0		
0	0	1	1	0	Screen #2 is selected to Character Disp.	X
0	0	1	1	1	Screen #2 is selected to Graphic Disp.	

As described in para.9, the screen #1 is available graphic display only and where will be displayed bit pattern as is written from external system.

The screen #2, however, is selectable to graphic or character display.

Within the graphic display in the screen #2, the bit pattern will be displayed like as the screen #1.

When selects the character display in the screen #2, the character which is corresponded to the character code will be displayed. A character consists of 6x8 dots. The character set is shown in the table below.

Since there are no control codes in the table, the writing position should be designated by the Cursor Setting Commands (OEH,OFH) from external system.

				D7	0	0	0	0	0	0	0	0	1	1	1	1	1	1	1					
				D6	0	0	0	1	1	1	1	0	0	0	0	1	1	1	1					
				D5	0	0	1	1	0	0	1	1	0	0	1	0	0	1	1					
				D4	0	1	0	1	0	1	0	1	0	1	0	1	0	1	0	1				
D3	D2	D1	D0		0	1	2	3	4	5	6	7	8	9	A	B	C	D	E	F				
0	0	0	0	0					0	1	2	3	4	5	6	7	8	9	A	B	C	D	E	F
0	0	0	1	1					!	!	!	!	!	!	!	!	!	!	!	!	!	!	!	!
0	0	1	0	2					"	"	"	"	"	"	"	"	"	"	"	"	"	"	"	"
0	0	1	1	3					#	#	#	#	#	#	#	#	#	#	#	#	#	#	#	#
0	1	0	0	4					\$	\$	\$	\$	\$	\$	\$	\$	\$	\$	\$	\$	\$	\$	\$	\$
0	1	0	1	5					%	%	%	%	%	%	%	%	%	%	%	%	%	%	%	%
0	1	1	0	6					&	&	&	&	&	&	&	&	&	&	&	&	&	&	&	&
0	1	1	1	7					'	'	'	'	'	'	'	'	'	'	'	'	'	'	'	'
1	0	0	0	8					<	<	<	<	<	<	<	<	<	<	<	<	<	<	<	<
1	0	0	1	9					>	>	>	>	>	>	>	>	>	>	>	>	>	>	>	>
1	0	1	0	A					*	*	*	*	*	*	*	*	*	*	*	*	*	*	*	*
1	0	1	1	B					+	+	+	+	+	+	+	+	+	+	+	+	+	+	+	+
1	1	0	0	C					,	,	,	,	,	,	,	,	,	,	,	,	,	,	,	,
1	1	0	1	D					=	=	=	=	=	=	=	=	=	=	=	=	=	=	=	=
1	1	1	0	E				
1	1	1	1	F					/	/	/	/	/	/	/	/	/	/	/	/	/	/	/	/

10.4 Data Write/Data Read

Command (C/ \overline{D} ="1")					Function
D4	D3	D2	D1	D0	
0	1	0	0	0	Data (pattern or character) Write
0	1	0	0	1	Data (pattern or character) Read

After sets of Cursor Address Setting Command, above Data Write or Data Read Commands will be given. The one byte data shall be written or be read during the line C/ \overline{D} ="0" sequentially.

The cursor address will be automatically incremented one address count after the data write or the data read when the command (04H) was given and this procedure will be continued sequentially unless data is stopped.

The cursor address will be held at the same position when the Command (05H) was given.

Caution! : Within the data read, the first byte just after the Data Read Command is invalid.

It is necessary a dammy read just after the data read command. The correct data will be read from the 2nd byte.

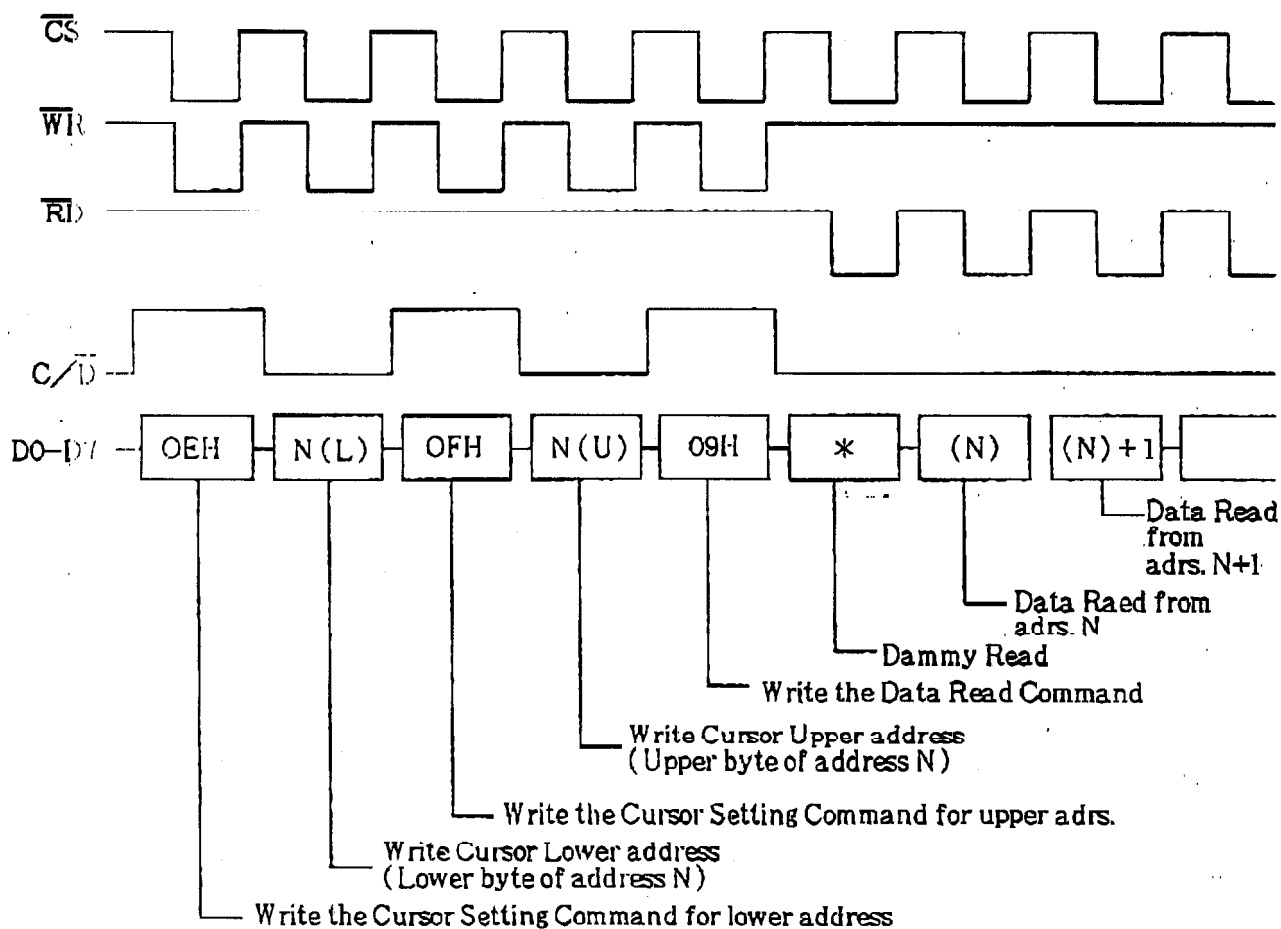

10.5 Setting of Display Start Address

Command (C/ \bar{D} ="1")					Setting Data (C/ \bar{D} ="0")								Function	
D4	D3	D2	D1	D0	D7	D6	D5	D4	D3	D2	D1	D0		
0	1	0	1	0	A7-----A0								Lower adrs of disp start	Screen
0	1	0	1	1	X	X	X	A12-----		A8			Upper adrs of disp start	#1
0	1	1	0	0	A7-----A0								Lower adrs of disp start	Screen
0	1	1	0	1	X	X	X	A12-----		A8			Upper adrs of disp start	#2

After writing of appropriate command from above, the display start address will be written into the address register.

The display start address is always pointed to the RAM address where is stored the data will be displayed at the left most and the top line of the screen. Using with these commands, page rolling, one-line-left/right scrolling (one dot unit) at graphics display or one-line-upper/lower scrolling (8 dot unit) at character display are available.

Since, FRP line is triggered at each frame of display, within the graphic display, the most smooth scrolling can be achieved by synchronizing of the change of the display address with the FRP line at every framing.

It is necessary to set the lower address first, then set the upper address of display start.

10.6 Cursor Address Set

Command (C/ \bar{D} ="1")					Setting Data (C/ \bar{D} ="0")								Function	
D4	D3	D2	D1	D0	D7	D6	D5	D4	D3	D2	D1	D0		
0	1	1	1	0	A7-----A0								Lower cursor adrs of #1 & #2	
0	1	1	1	1	X	X	X	A12-----		A0			Upper cursor adrs of #1 & #2	

The cursor address is written into the cursor address counter by this command.

The cursor address means the address of Read/Write address of displaying data in the RAM.

It is necessary to set the cursor address before execution of data write command (08H) or data read command (09H).

The cursor address is divided into the 2 portions as upper (5 bits) and lower (8 bits) address and there are following restrictions.

desire to change (set) the address both upper and lower	first, set the lower and then upper address
desire to change (set) the lower address only	upper address set is required after setting of lower address
desire to change (set) the upper address only	set the upper address. not need to change (set) the lower address

10.7 Screen Lumiance Control

Command (C/ \bar{D} ="1")					Function		
D4	D3	D2	D1	D0			
1	1	0	0	0	Level	1	100.0%
1	1	0	0	1	Level	2	87.5%
1	1	0	1	0	Level	3	75.0%
1	1	0	1	1	Level	4	62.5%

Screen Lumiance can be varied by above command.

At power on, Screen Lumiance is set to 100%.

11. Blanking

Display will be blanked by BL="0". There are no change in the RAM during blanking, previous display will be recovered by BL="1".

12. Address Map

12.1 Graphic Display

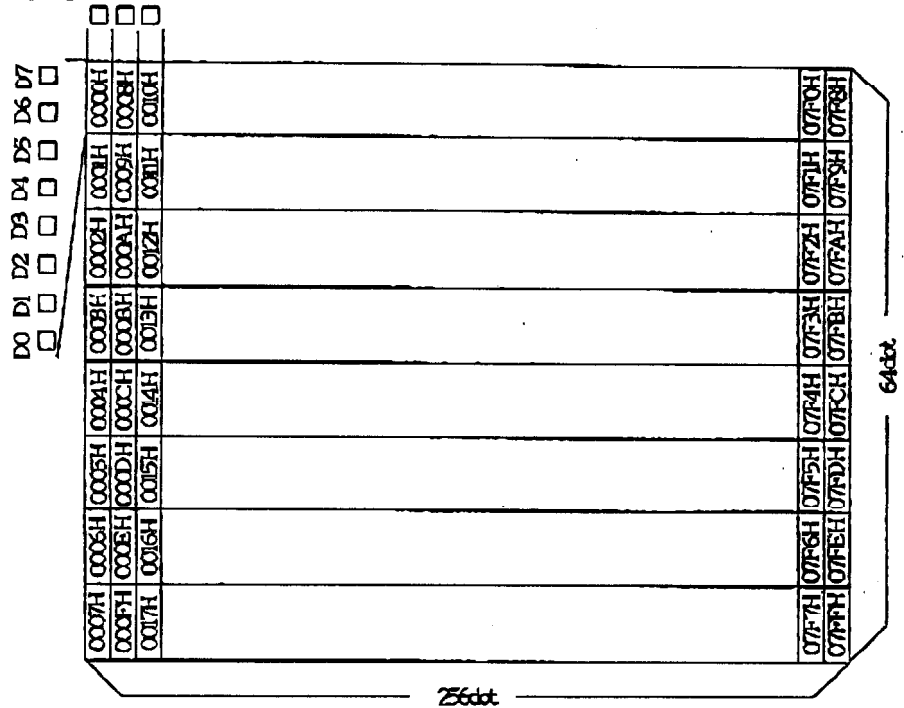

... Above map shows in the case of 0000H of start address ...

12.2 Character Display

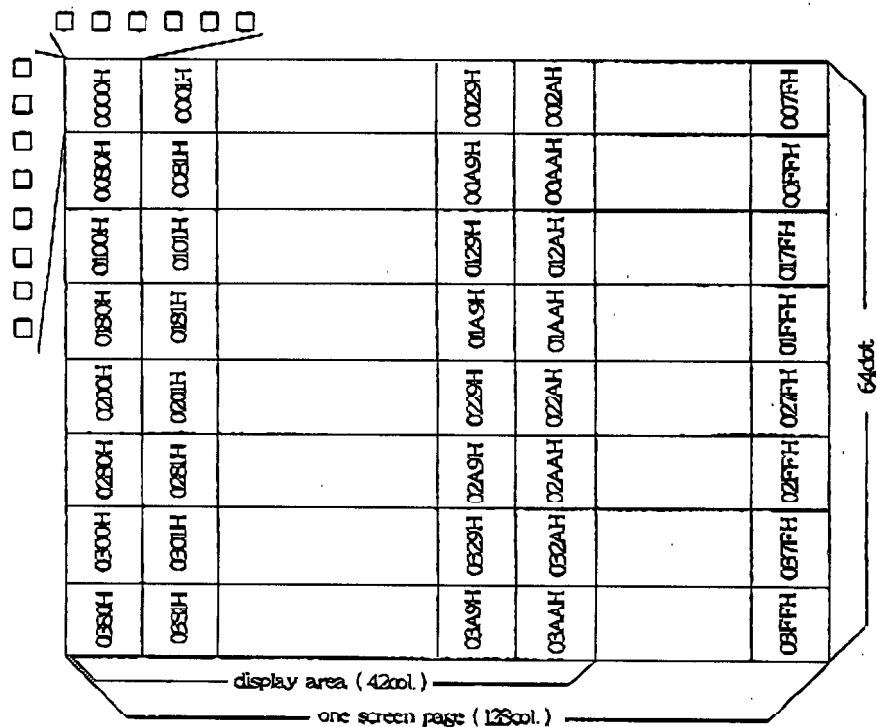

... Above map shows in the case of 0000H of start address ...

13. Interfacing

\overline{CS}	\overline{WR}	\overline{RD}	C/\overline{D}	\overline{BL}	Function
0	0 → 1	1	1	-	Command write (Host system → Module)
0	0 → 1	1	0	-	Data Setting (Disp data, Address) (Host → Module)
0	1	0	1	-	-----
0	1	0	0	-	Display data read (Host system ← Module)
-	-	-	-	0	Display Blanking

Since data executing time in the module is only 2 μ sec. maximum, there is not provided Busy signal / flag at the command write / data write / data read from the host system. And therefore, more than 2 μ sec. period for accessing from the host system is required between data.

[An example of interfacing]

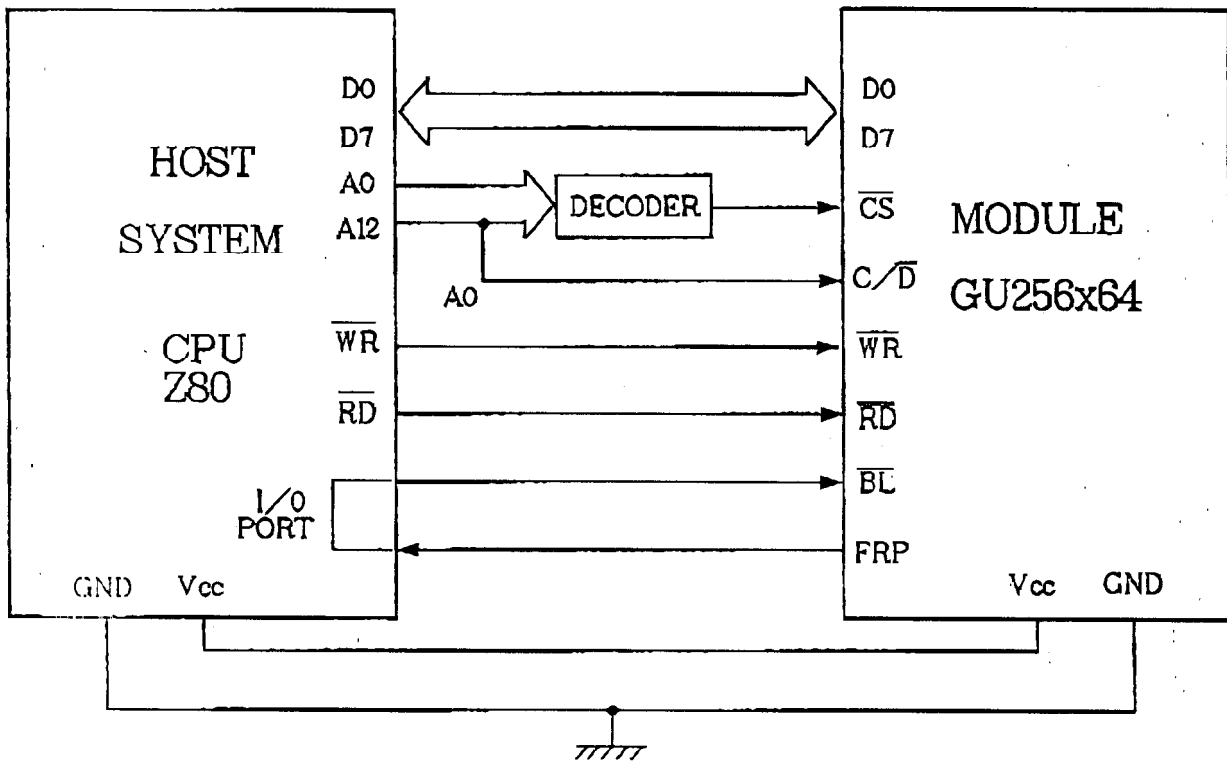

Caution! Because adoption of CMOS input logics in the module, shorter than 30 cm cable length between the host system and the module is kindly suggested for free from permanent damage caused of noise.

14.1 Write Operation

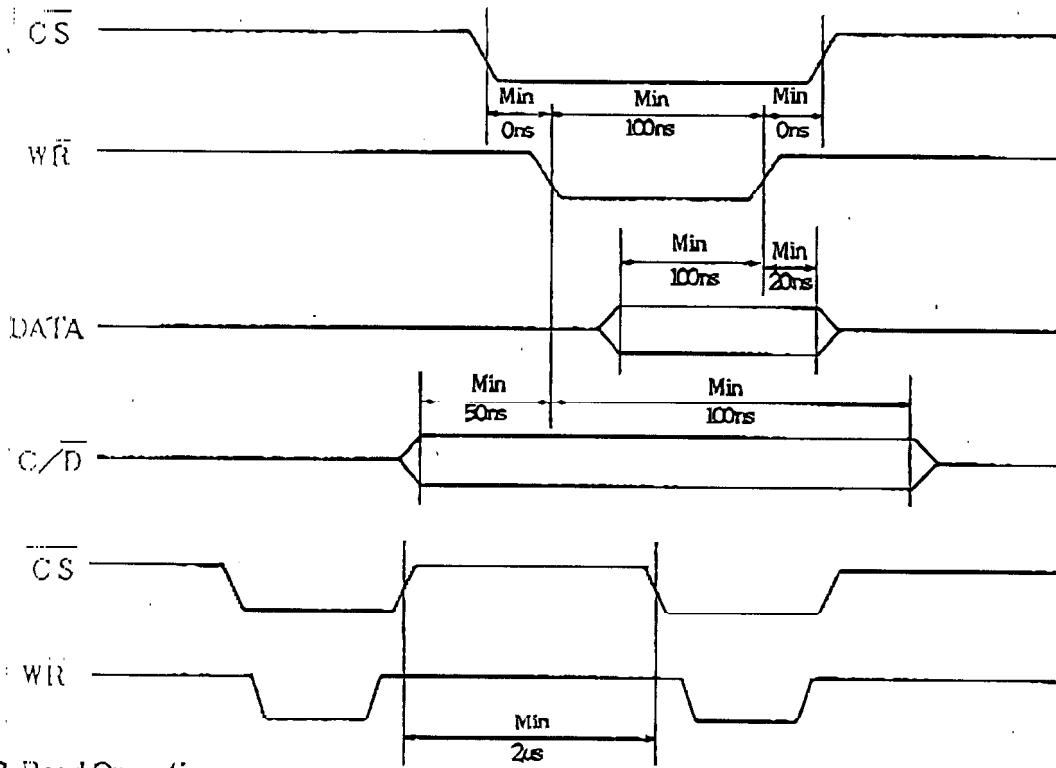

14.2 Read Operation

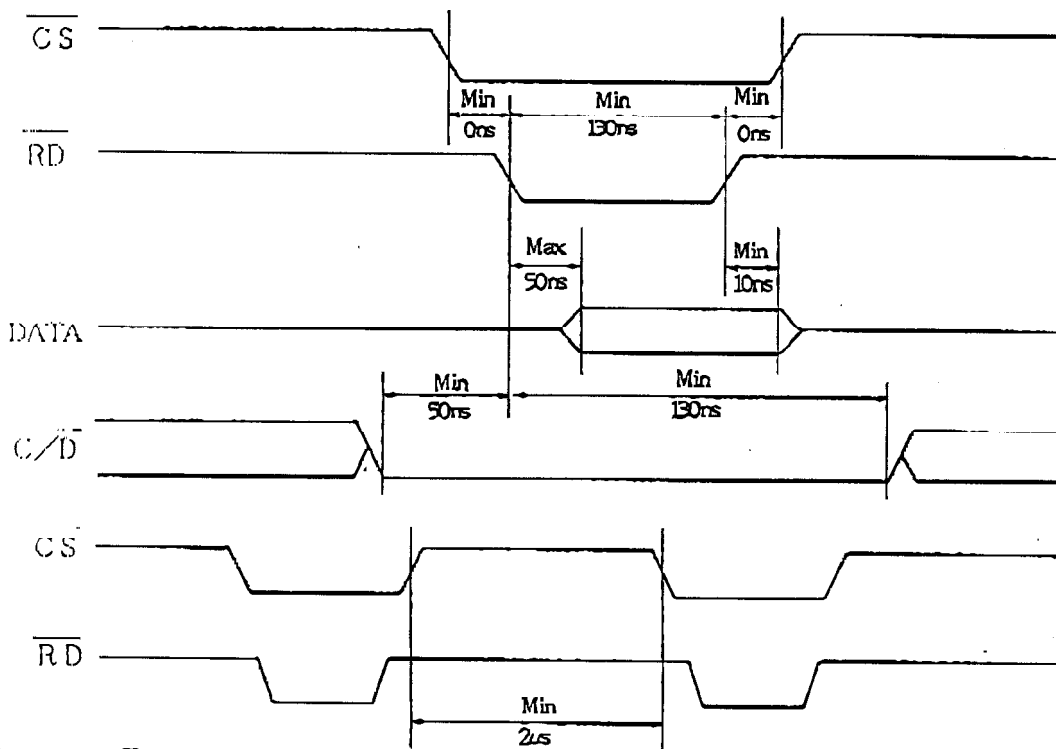

14.3 Output Timing of FRP

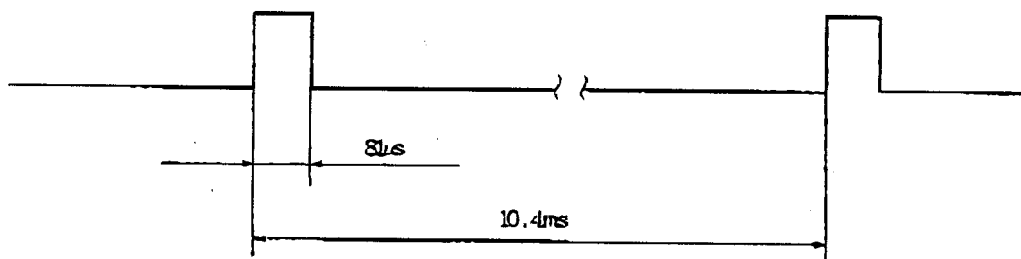

15. Pin Assignment

Signal Connector

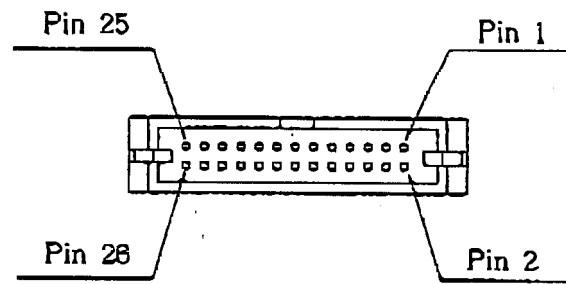

Pin No.	Description	Pin No.	Description
1	D7	2	GND
3	D6	4	GND
5	D5	6	GND
7	D4	8	GND
9	D3	10	GND
11	D2	12	GND
13	D1	14	GND
15	D0	16	GND
17	\overline{WR}	18	GND
19	C/\overline{D}	20	GND
21	\overline{RD}	22	GND
23	\overline{CS}	24	GND
25	FRP	26	\overline{BL}

Power Connector

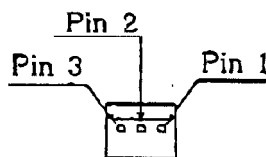

Pin No.	Description
1	+5V (Vcc)
2	NC
3	GND

Caution ! Suppling of Vcc (+5 V) is available from the connector 1 or connector 2 since Vcc and GND lines are tied in the module respectively, however, in the case of suppling the Vcc from the connector 1 only, the post header of connector 2 is exposed. Carefull handling around the connector 2 is required.

16. Outline Dimension

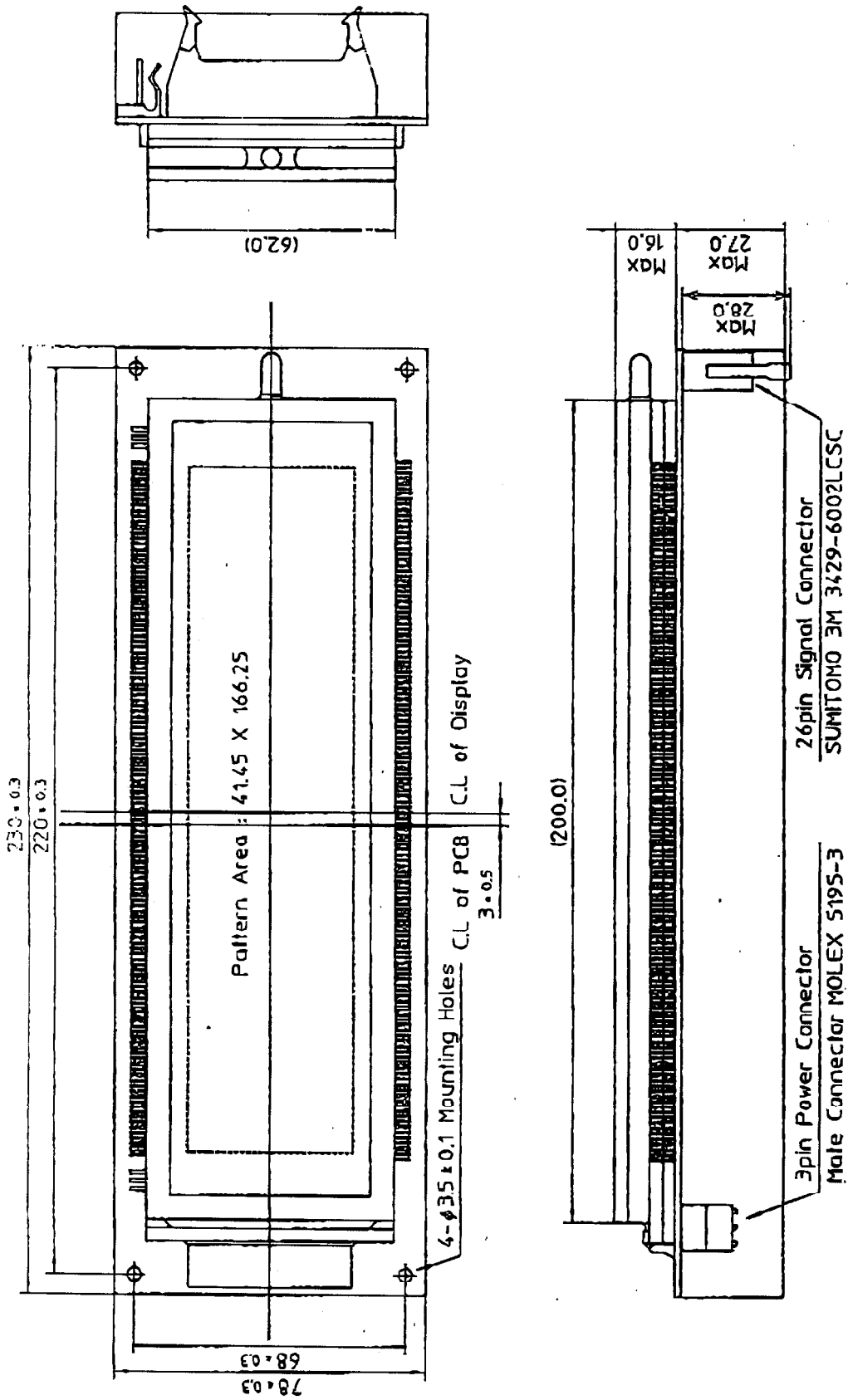

IMPORTANT PRECAUTIONS

- * All VFD Modules contain MOS LSIs or ICs. Anti-Static handling procedures are always required.
- * VF Display consists of Soda-lime glass. Heavy shock more than 100 G, thermal shock greater than 10°C/minute, direct hit with hard material to the glass surface — especially to the EXHAUST PIPE — may CRACK the glass.
- * Do not PUSH the display strongly. At mounting to the system frame, slight gap between display glass face and front panel is necessary to avoid a contact failure of lead pins of display. Twist or warp mounting will make a glass CRACK around the lead pin of display.
- * Neither DATA CONNECTOR or POWER CONNECTOR should be connected or disconnected while power is applied. As is often the case with most subsystems, caution should be exercised in selectively disconnecting power within a computer based system. The modules receive high logic on strobe lines as random signals on all data ports.
Removal of primary power with logic signals applied may damage input circuitry.
- * Stress more than specification listed under the Absolute Maximum Ratings may cause PERMANENT DAMEGE of the modules.
- * +5 volts power line must be regulated completely since all control logics depend on this line.
Do not apply slow-start power. Provide sufficient output current power source to avoid trouble of RUSH CURRENT at power on. (At least output current of double figure of I_{cc} , listed on the specification of each module, is required.)
- * Data cable length between module and host system is recommended within 300 mm to be free from a mis-operation caused by noise.
- * Do not place the module on the conductive plate just after the power off. Due to big capacitors on the module, more than 1 min. of discharging time is required to avoide the failure caused by shorting of power line.
- * The module contains high voltage (120 V) power source. Carefull handling is required when it is powered on.