

Copyright 2013 Parallax Incorporated. This work is released under the Creative Commons Attribution 3.0 United States License. The full text of the license is available from: <http://creativecommons.org/licenses/by/3.0/us/legalcode>

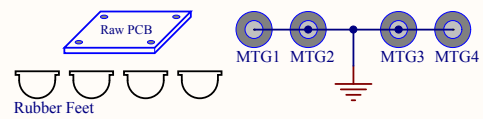

Title			Propeller Activity Board		
Size	Number	Revision			
Letter	32910			A	
Date:	5/28/2013	Sheet 1 of 12			
File:	L:\Products\Propeller Activity Board.SchDoc				

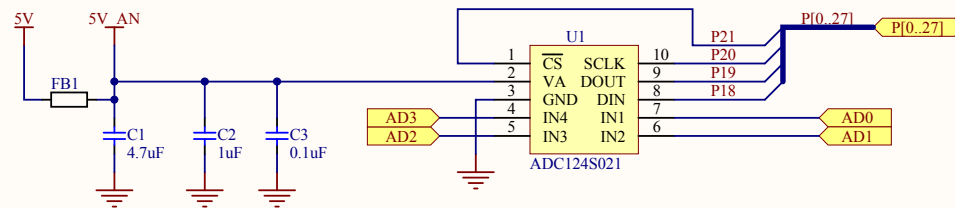

Title			Propeller Activity Board		
Size	Number	Revision			
Letter	32910	A			
Date:	5/28/2013	Sheet 2 of 14			
File:	L:\Products\ADC.SchDoc	Drawn By:			

USB Connection PWR/UART

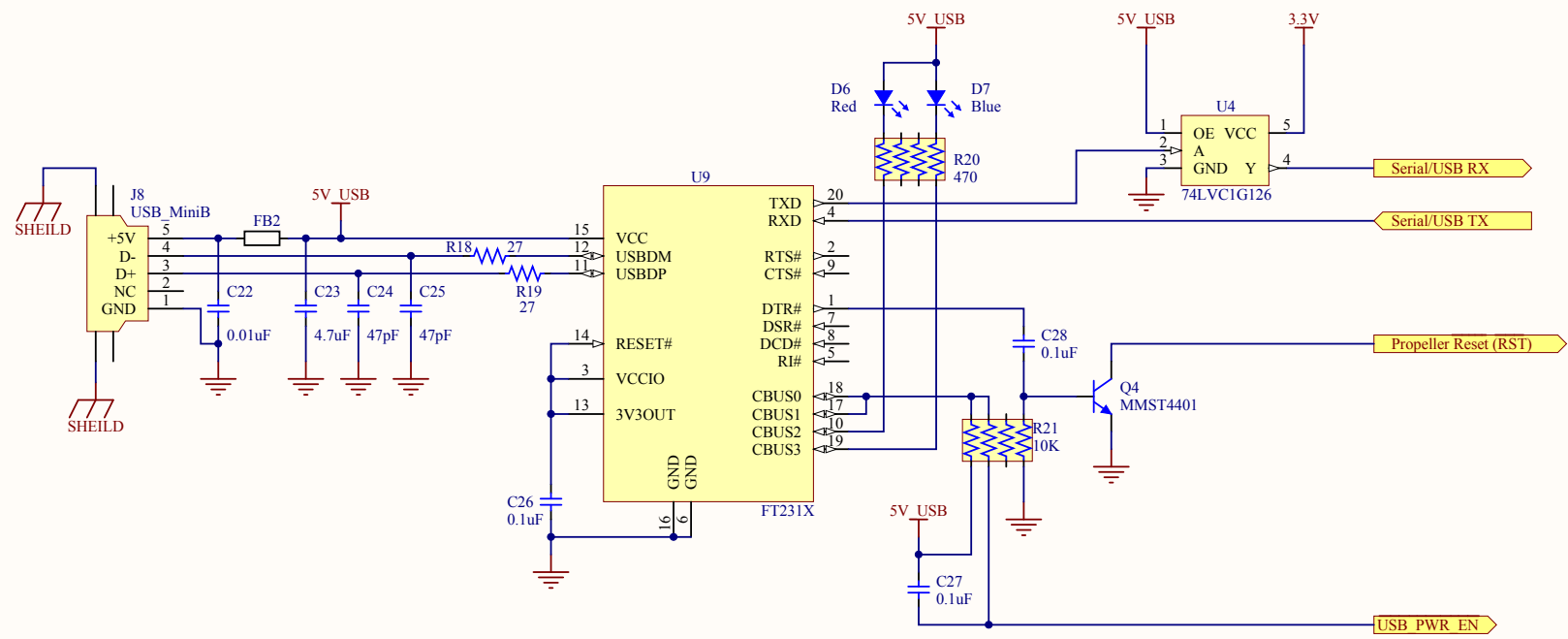

Title			Propeller Activity Board		
Size	Number	Revision			
Letter	32910	A			
Date:	5/28/2013	Sheet of			
File:	L:\Products\USB.SchDoc	Drawn By:			

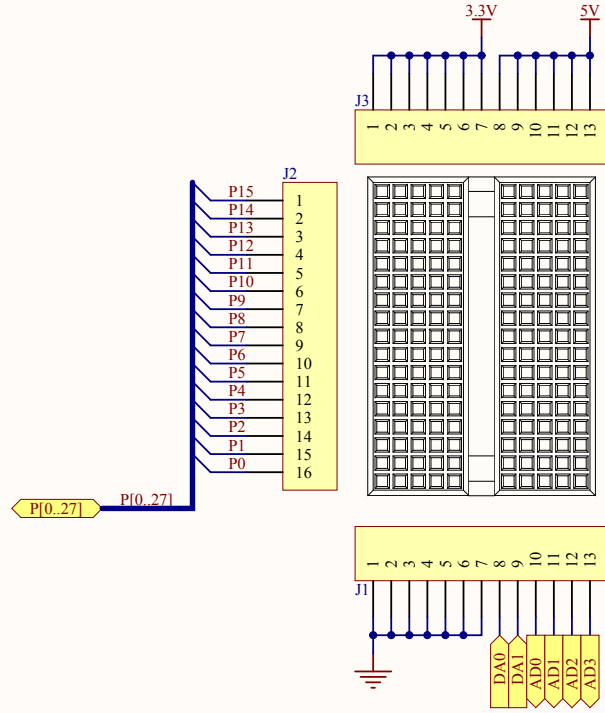

Title			Propeller Activity Board		
Size	Number	Revision			
Letter	32910	A			
Date:	5/28/2013	Sheet 3 of 14			
File:	L:\Products\...\Breadboard.SchDoc	Drawn By:			

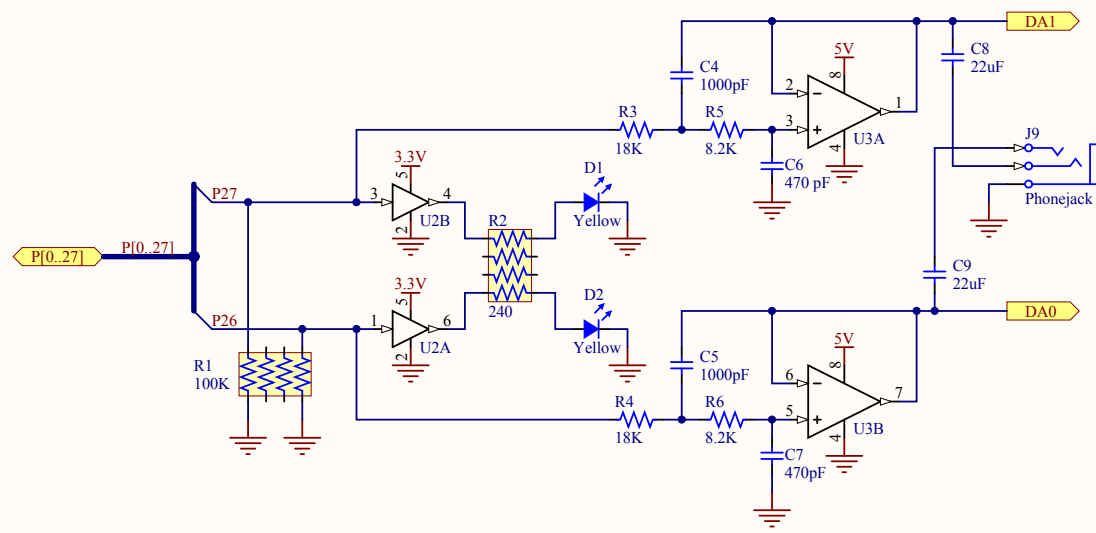

Title			Propeller Activity Board		
Size	Number	Revision			
Letter	32910	A			
Date:	5/28/2013	Sheet 4 of 14			
File:	L:\Products\DAC.SchDoc	Drawn By:			

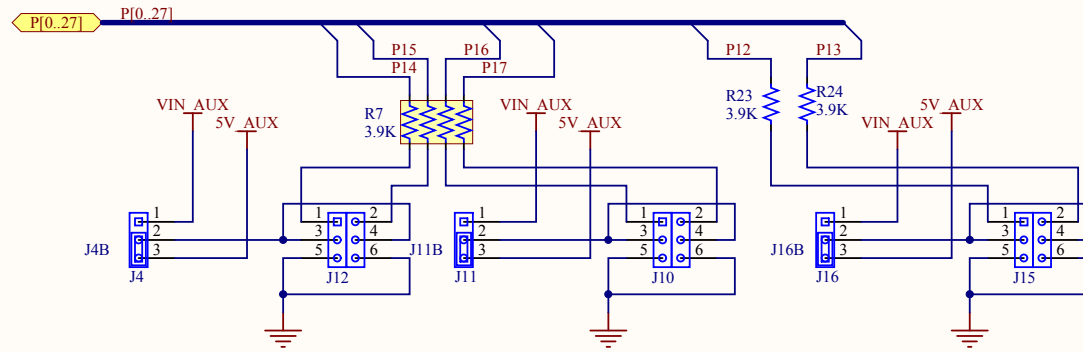

Title			Propeller Activity Board		
Size	Number	Revision			
Letter	32910	A			
Date:	5/28/2013	Sheet 5 of 14			
File:	L:\Products\...\Headers.SchDoc	Drawn By:			

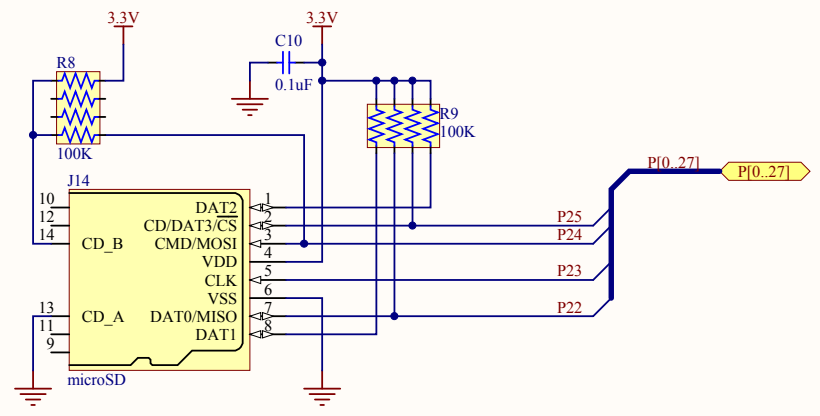

Title			Propeller Activity Board		
Size	Number	Revision			
Letter	32910	A			
Date:	5/28/2013	Sheet 7 of 14			
File:	L:\Products\...\MicroSD.SchDoc	Drawn By:			

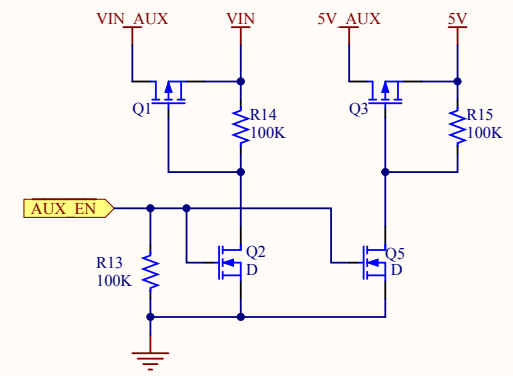
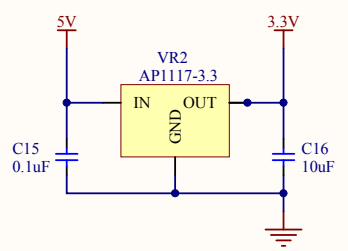
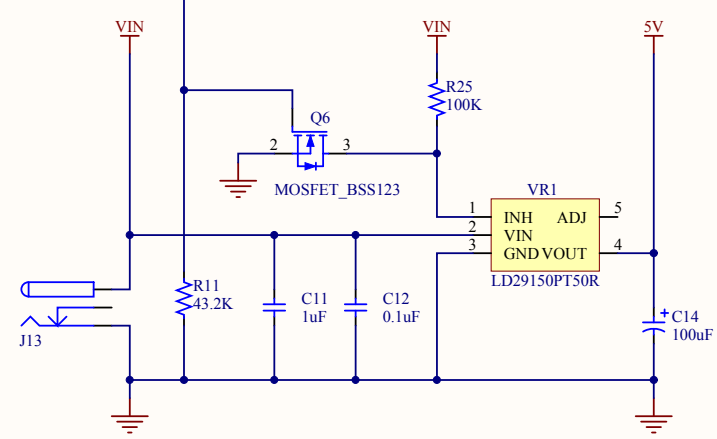
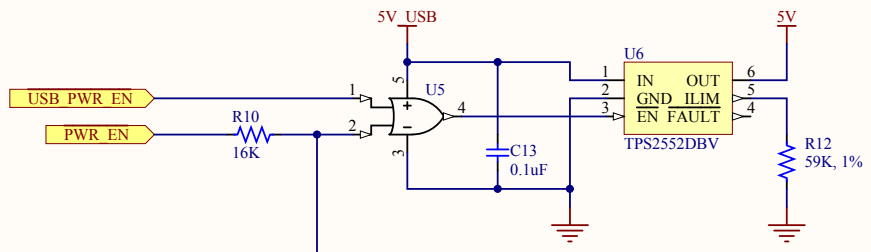

Title			Propeller Activity Board		
Size	Number	Revision			
Letter	32910	A			
Date:	5/28/2013	Sheet 8 of 14			
File:	L:\Products\...\Power.SchDoc	Drawn By:			

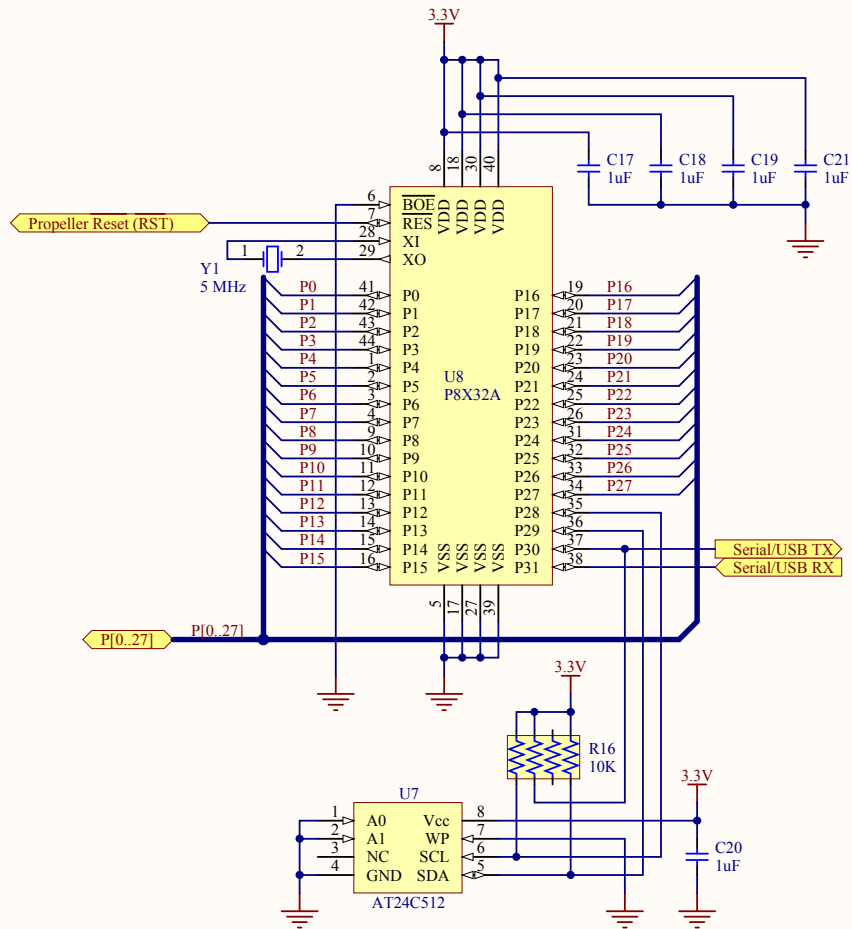

Title		
Propeller Activity Board		
Size	Number	Revision
Letter	32910	A
Date:	5/28/2013	Sheet 9 of 14
File:	L:\Products\...\Propeller.SchDoc	Drawn By:

1

2

3

4

A

A

B

B

C

C

D

D

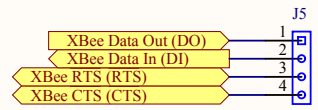

Title			Propeller Activity Board		
Size	Number	Revision			
Letter	32910	A			
Date:	5/28/2013	Sheet 10 of 14			
File:	L:\Products\...\Socket.SchDoc	Drawn By:			

1

2

3

4

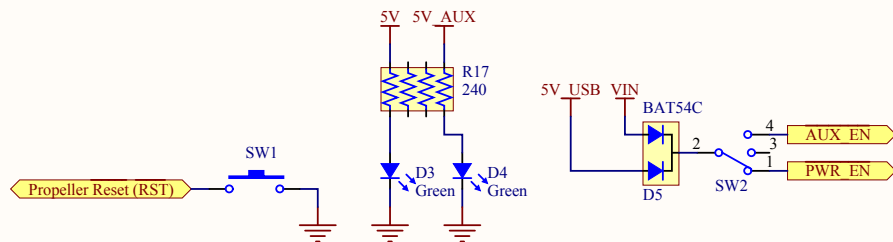

Title			Propeller Activity Board		
Size	Number	Revision			
Letter	32910	A			
Date:	5/28/2013	Sheet 1 of 14			
File:	L:\Products\Switch_SchDoc	Drawn By:			

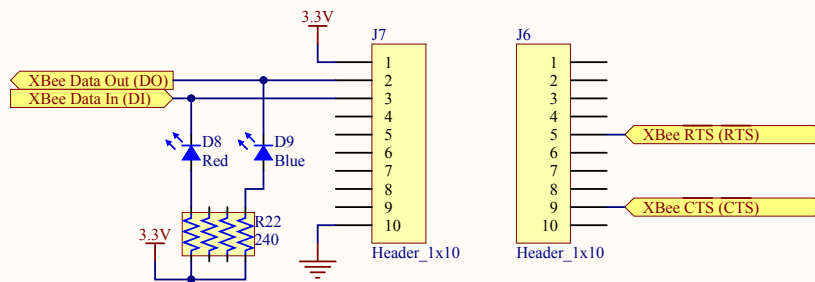

Title			Propeller Activity Board		
Size	Number	Revision			
Letter	32910	A			
Date:	5/28/2013	Sheet 4 of 14			
File:	L:\Products\Xbee.SchDoc	Drawn By:			

PROPELLER ACTIVITY BOARD REV A

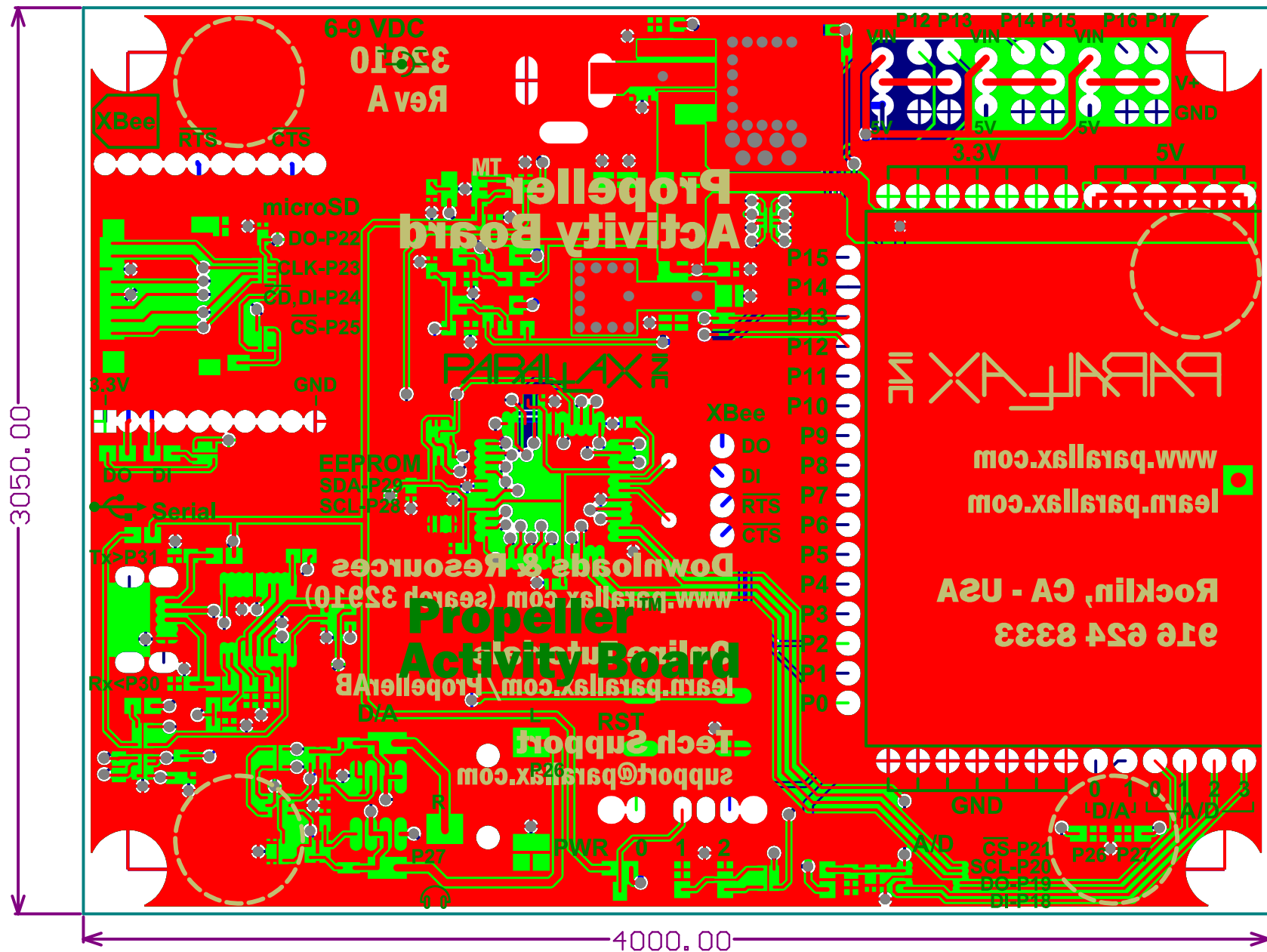

ASSY NOTES

- 1) Solder parts per IPC-A-610E.
- 2) Finished product to be clean of all flux and foreign material.

Bill of Materials:

Part Number: 32910

Revision: A

Propeller Activity Board

Product Owner:

Last Updated:

Education

5/28/2013 9:08:11 AM

#	Parallax_PN	Quantity	Designator	Value	#Column Name Error:Syspro_Desg	Orderable Part Number	Name	Digikey_PN	mn Name Error:Mouse_f
1	150-11038	2	R18, R19			P27GCT-ND		P27GCT-ND	
2	150-12022	1	R10			P16KJTR-ND		P16KJTR-ND	
3	150-12024	2	R23, R24			P3.90KLC T-ND		P3.90KLC T-ND	
4	172-16000	2	R5, R6			P8.20KHTR-ND		P8.20KHTR-ND	
5	172-16001	2	R3, R4			311-18.0KLRTR-ND		311-18.0KLRTR-ND	
6	172-16005	1	R12			RMCF0402FT59K0TR-ND		RMCF0402FT59K0R-ND	
7	172-16007	1	R11			311-43.2KLRTR-ND		311-43.2KLRTR-ND	
8	173-01040	4	R13, R14, R15, R25			RMCF0402JT100KCT-ND		RMCF0402JT100KCT-ND	
9	179-10000	2	R16, R21			RAVF104DJT10K0-ND		RAVF104DJT10K0-ND	
10	179-10006	3	R2, R17, R22			CRA4S8240TR-ND		CRA4S8240TR-ND	
11	179-10007	3	R1, R8, R9			RAVF104DJT100KTR-ND		RAVF104DJT100KTR-ND	
12	179-10008	1	R20			RAVF104DJT470RTR-ND		RAVF104DJT470RTR-ND	
13	179-10009	1	R7			CRA4S83.9KTR-ND		CRA4S83.9KTR-ND	
14	200-10502	2	C6, C7			311-1028-2-ND		311-1028-2-ND	
15	200-10503	2	C4, C5			478-3661-1-ND		478-3661-1-ND	
16	200-11041	1	C26			399-1096-2-ND		399-1096-2-ND	
17	200-11503	1	C16			445-3458-2-ND		445-3458-2-ND	
18	200-11507	2	C8, C9			445-7665-2-ND		445-7665-2-ND	
19	200-11509	3	C3, C10, C12			311-1375-2-ND		311-1375-2-ND	
20	200-11511	7	C2, C11, C17, C18, C19, C20, C21			445-4991-1-ND		445-4991-1-ND	
21	200-11518	1	C14			565-2105-2-ND		565-2105-2-ND	
22	200-11532	2	C24, C25			445-1277-1-ND		445-1277-1-ND	
23	213-01040	2	C13, C15			490-1575-2-ND		490-1575-2-ND	
24	213-01040	2	C27, C28			311-1375-2-ND		311-1375-2-ND	
25	213-01041	1	C22			399-1091-2-ND		399-1091-2-ND	
26	213-04761	2	C1, C23			490-3302-2-ND		490-3302-2-ND	
27	251-05000	1	Y1			X1050-ND		X1050-ND	
28	275-10004	2	FB1, FB2			445-1565-1-ND		445-1565-1-ND	
29	300-32910	1	PCB1						
30	350-10001	2	D6, D8			160-1447-2-ND		160-1447-2-ND	
31	350-10002	2	D1, D2			160-1448-2-ND		160-1448-2-ND	
32	350-10003	2	D3, D4			160-1446-2-ND		160-1446-2-ND	
33	350-10004	2	D7, D9			754-1434-2-ND		754-1434-2-ND	
34	400-10002	1	SW1			CKN9112TR-ND		CKN9112TR-ND	
35	400-10007	1	SW2			CKN9543-ND		CKN9543-ND	
36	400-10008	1	U6			296-23988-2-ND		296-23988-2-ND	
37	450-00105	3	J10, J12, J15			S2011E-03-ND		S2011E-03-ND	
38	450-00401	1	J5			3M9515-ND		3M9515-ND	
39	450-01301	2	J1, J3			S7046-ND		S7046-ND	
40	450-01601	1	J2			S7014-ND		S7014-ND	
41	450-01701	2	J6, J7			S5751-10-ND		S5751-10-ND	
42	451-01030	3	J4, J11, J16			3M9322-ND		3M9322-ND	
43	452-00007	1	J13			SC1313-ND		SC1313-ND	
44	452-00050	3	J4B, J11B, J16B			S3404-ND		S3404-ND	
45	452-10017	1	J14			HR1941TR-ND		HR1941TR-ND	
46	452-10018	1	J9			CP-3523SJCT-ND		CP-3523SJCT-ND	
47	452-10020	1	J8			WM5462CT-ND		WM5462CT-ND	
48	500-10000	1	Q4			MMST4401TPMSCT-ND		MMST4401TPMSCT-ND	
49	500-10015	2	Q2, Q5			2N7002-TPMSCT-ND		2N7002-TPMSCT-ND	
50	500-10016	1	Q6			568-4837-2-ND		568-4837-2-ND	
51	500-10025	2	Q1, Q3			DMP2305UDITR-ND		DMP2305UDITR-ND	
52	501-10023	1	D5			BAT54C-FDITR-ND		BAT54C-FDITR-ND	
53	601-00523	1	VR1			497-4249-1-ND		497-4249-1-ND	
54	601-10504	1	VR2			AP1117E33GDICT-ND		AP1117E33GDICT-ND	
55	602-10001	1	U7			497-6349-2-ND		497-6349-2-ND	
56	603-10010	1	U4			74LVC1G126SE-7DITR-ND		74LVC1G126SE-7DITR-ND	
57	603-10014	1	U2			NC7WZ17P6XCT-ND		NC7WZ17P6XCT-ND	
58	603-10016	1	U3			497-8165-2-ND		497-8165-2-ND	
59	604-00065	1	U9			768-1129-1-ND		768-1129-1-ND	
60	604-10014	1	U1			ADC124S021CIMM/NOPBCT-ND		ADC124S021CIMM/NOPBCT-ND	
61	604-10026	1	U5			568-2298-1-ND		568-2298-1-ND	
62	700-00012	1	Breadboard1			700-00012-ND		700-00012-ND	
63	700-00037	1	Feet1			SJ5003-0-ND		SJ5003-0-ND	
64	P8X32A-Q44	1	U8			P8X32A-Q44-ND		P8X32A-Q44-ND	