

Propeller Control Board (#28205)

General Description

The Propeller Control Board is a complete solution for controlling robotics platforms. This is the same control board that ships with our Quad Rover robot. The Propeller Control Board is capable of interfacing directly with the Parallax GPS Module, our Hitachi HM55B Compass Module and our Hitachi H48C 3-Axis Accelerometer. This provides options for tracking position, heading and acceleration for robotic applications.

12 of the Propeller I/O pins are brought out to headers for customer interfacing and control applications, 8 are dedicated to servo control and 8 are dedicated to N-Channel MOSFET outputs, providing high-current drivers for solenoids or other high-current devices. There is also a magneto-pickup compatible tachometer input which can be used for measuring the RPM of gasoline engines.

Features

- Propeller P8X32A-Q44 Microcontroller
- 64KB EEPROM (32KB used for program storage)
- Tachometer input
- (12) auxiliary I/O connections with 10K Ω series protection resistors
- (8) servo headers
- (8) N-Channel MOSFET driver outputs
- 3-Position power switch (off, Propeller on/Servos off, Propeller/Servos on)
- Mounting locations/connections for Parallax GPS Module, Hitachi H48C 3-Axis Accelerometer and Hitachi HM55B Compass Module

Application Ideas

- Robotic Control
- Vehicle Fleet Management (used with GSM modem)
- Living Art
- Custom engine control for go-carts

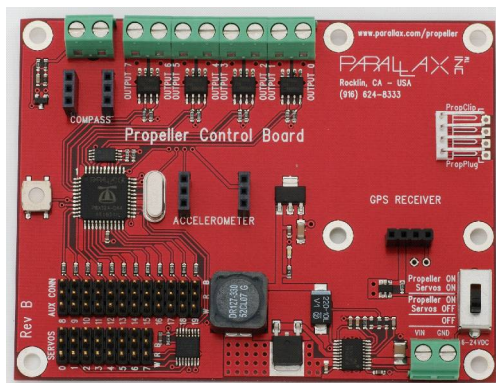

Connecting and Testing

Connect 6-24VDC to the power input terminal block on the bottom right of the control board. Connect a Prop Plug or Prop Clip to the programming interface on the upper right side of the control board. Slide the power switch to the center position (Propeller ON, servos OFF) and press F7 from within the Propeller Tool software to verify that the Propeller Chip is detected.

Resources and Downloads

You may download free (example programs, articles, etc.) from the Propeller Control Board product page on our website. Go to <http://www.parallax.com> and enter the part number (28205) in the search box. You can also find Propeller Objects on the Object Exchange. Go to <http://obex.parallax.com> and search by keyword or category.

Servo Operation

Servos on the control board are not directly connected to the I/O pins on the Propeller, but rather they are connected through a 74HC4017 Johnson decade counter. By using this counter IC the Propeller can easily control eight servos using only two I/O lines. Servo pulses are generated by stepping the counter outputs at the pulse width for each servo output. The counter is reset every 20mS period and the pulse widths for each channel are obtained from an array. A SPIN object that drives the counter IC is located on the product web page.

Compass Operation

Having a compass module means you can get heading information, even when not moving. The Propeller Control Board supports the Parallax HM55B Compass Module. The socket for this module is located near the top left corner of the board and the 6-pin module seats right into the two 3-pin sockets with pin 1 being toward the top left. Objects supporting this module can be downloaded from the Propeller Object Exchange listed above.

Accelerometer Operation

An accelerometer will allow you to measure acceleration and even tilt. The Propeller Control Board supports the Parallax H48C Tri-Axis Accelerometer. The socket for this module is located near the center of the board and the 6-pin module seats right into the two 3-pin sockets with pin 1 being toward the top left. Objects supporting this module can be downloaded from the Propeller Object Exchange listed above.

GPS Operation

In order to navigate from one outside location to another a GPS Module can be used. The Propeller Control Board supports the Parallax GPS Module. The socket for this module is located near the top right corner of the board and the module is designed to install with the pins toward the bottom. Using $\frac{3}{4}$ " standoffs, the GPS module can be mounted directly to the Propeller Control Board using the available mounting holes on the four corners. Objects supporting this module can be downloaded from the Propeller Object Exchange listed above.

The Parallax GPS Module supports both a smart mode as well as raw mode where the NMEA data is sent via long strings. By default simply plugging the module in will leave it in smart mode where you can query it for individual pieces of data. Should you wish to utilize the raw mode there is an optional jumper that can be installed just below the socket. You can either solder a wire jumper across the two unpopulated holes or install a 2-pin SIP header and jumper block. When the wire or jumper is installed it will force the GPS to use raw mode by bringing its /RAW pin low.

I/O Pin Connections and Assignments

The table below shows where each Propeller I/O pin connects on the control board

I/O Pin	Name	Connection
0	FET Output 0	½ FDS6990A Gate (10K pull down)
1	FET Output 1	½ FDS6990A Gate (10K pull down)
2	FET Output 2	½ FDS6990A Gate (10K pull down)
3	FET Output 3	½ FDS6990A Gate (10K pull down)
4	FET Output 4	½ FDS6990A Gate (10K pull down)
5	FET Output 5	½ FDS6990A Gate (10K pull down)
6	FET Output 6	½ FDS6990A Gate (10K pull down)
7	FET Output 7	½ FDS6990A Gate (10K pull down)
8	AUX 8	Series 10K resistor
9	AUX 9	Series 10K resistor
10	AUX 10	Series 10K resistor
11	AUX 11	Series 10K resistor
12	AUX 12	Series 10K resistor
13	AUX 13	Series 10K resistor
14	AUX 14	Series 10K resistor
15	AUX 15	Series 10K resistor
16	AUX 16	Series 10K resistor
17	AUX 17	Series 10K resistor
18	AUX 18	Series 10K resistor
19	AUX 19	Series 10K resistor
20	Tachometer Input	Protected input (from magneto on gas engine)
21	GPS I/O	Data line from Parallax GPS Module
22	ServoMR	74HC4017 Master Reset
23	ServoCP	74HC4017 Clock Input
24	Compass Select	HM55B /EN Line (Output to compass module)
25	Accelerometer Select	H48C /CS Line (Output to Accelerometer)
26	SPI Clock	SPI Clock Common Bus (Output)
27	SPI Data	SPI Data Common Bus
28	I ² C Clock	I ² C Clock Common Bus (AT24C512 EEPROM)
29	I ² C Data	I ² C Data Common Bus (AT24C512 EEPROM)
30	TX	Transmit Data (Output to programming connector)
31	RX	Receive Data (Input from programming connector)

Specifications

Parameter	Minimum	Typical	Maximum	Units
Supply Voltage	6	12	24	V
Quiescent Current @ 12VDC †	—	10	—	mA
FDS6990A FET Current Sink*	—	7.5	20	A
Magneto Input Threshold	4.88	5.21	5.58	V
Absolute Maximum Magneto Input Voltage	-1.3	—	1.3	kV
Operating Temperature	0	—	70	°C

† No additional hardware connected

* @ 30V, datasheet for details

Connection Diagram

Dimensions: 4" W x 3" H x 1/2" D (101.6mm W x 76.2mm H x 12.7mm D)

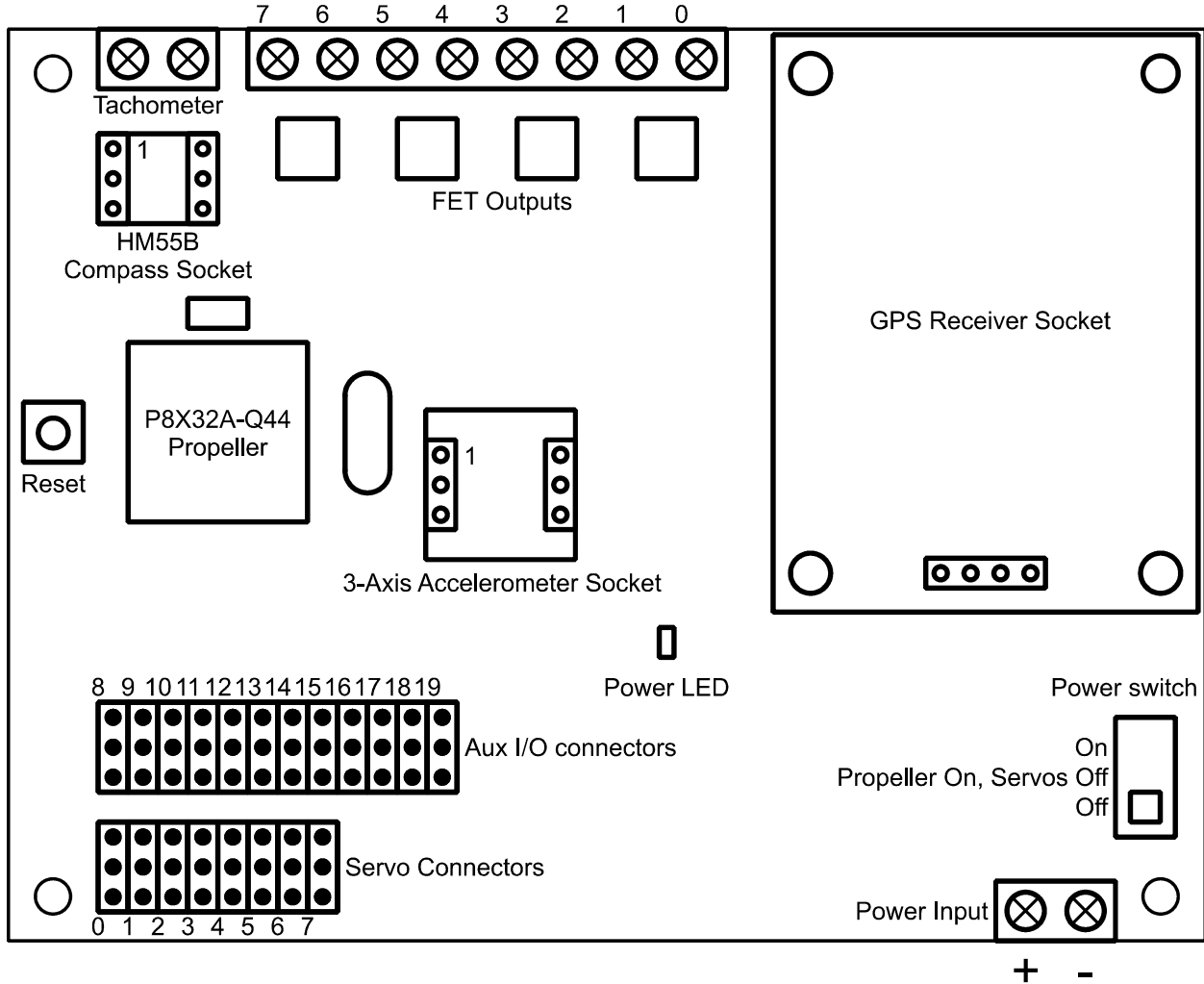

Propeller Control Board Schematic

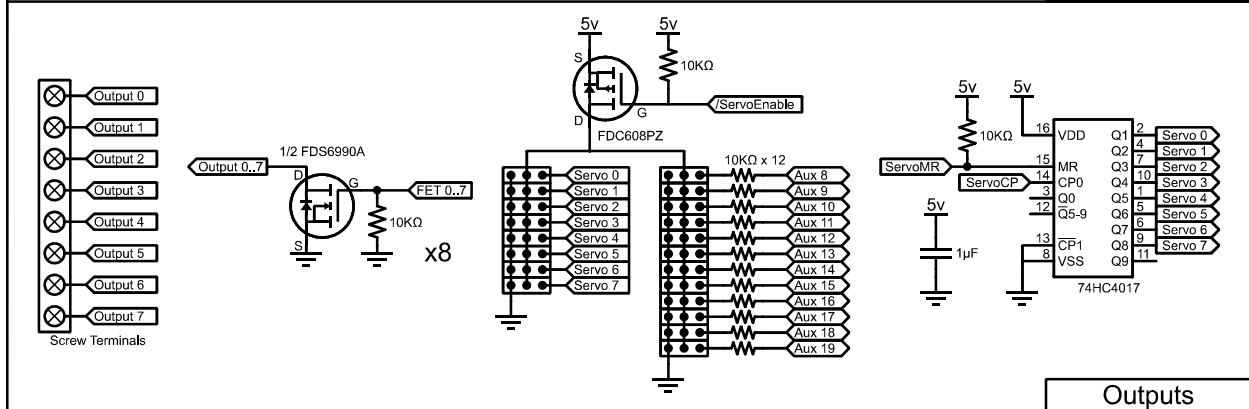
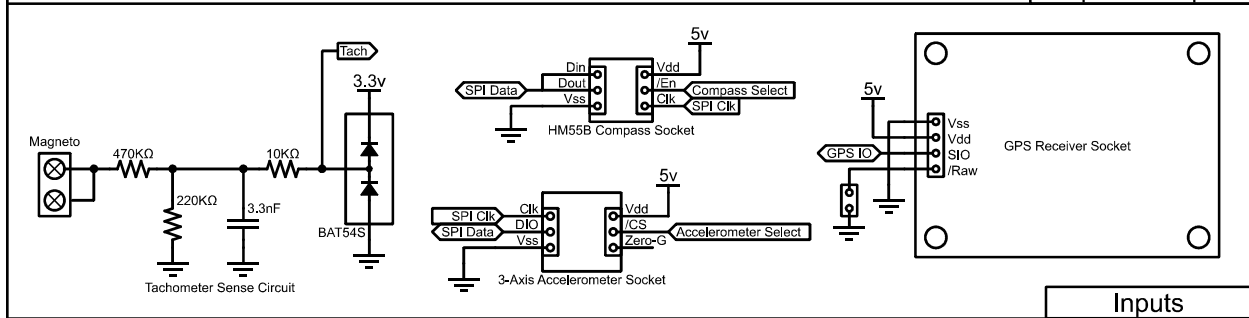
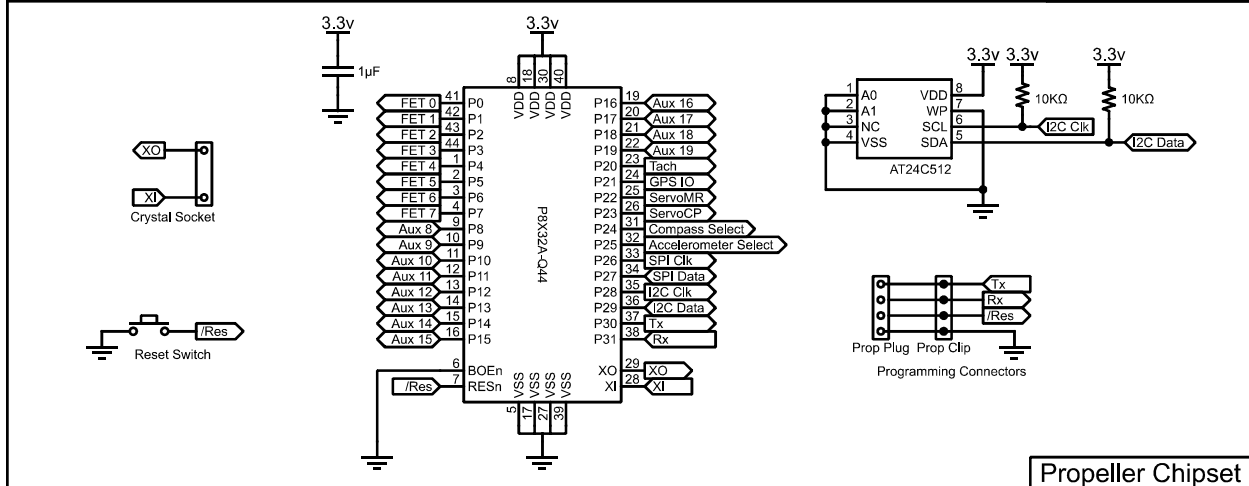
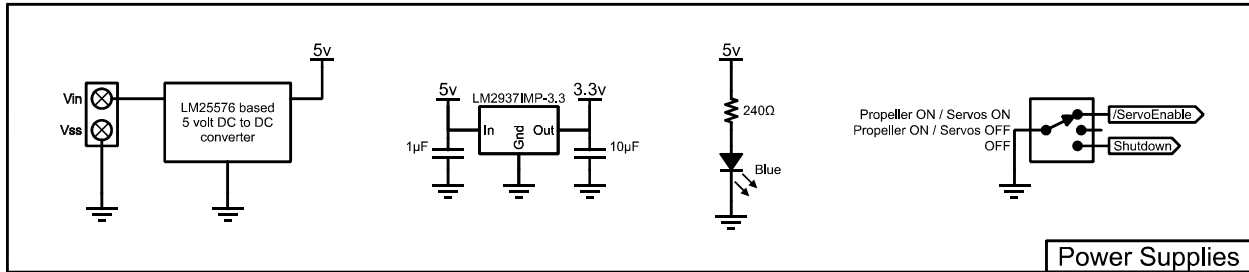

Propeller Control Board

Rev A Schematic