



## Main Features

- Control circuit and RGB chip are integrated in a package of 5050 components, form a complete control of pixel point,has a same outlook with 5050 LED.
- Signal adopts the single line parallel connection type,any pixels failure won't effect other pixel's display effect.
- Signal can compatible and expand the DMX512(1990) protocol signal.Data transmission speed can be 250Kbps~750Kbps.
- Each pixel's three primary color can achieve 256 brightness display, completed 16777216 color full color display, and scan frequency can be 3000Hz/s.
- EEPROM integrated in and maximum support 1024pixels in parallel connection.

## Main Application

- Stage light control system,etc;
- LED decoration lighting system,etc;
- All kinds of creative clothes,crafts,etc;
- All kinds of game devices,electronic toy,etc;
- Large dancing machine, fitness facility and entertainment facilities,etc;

## General Description

WS2822S is an intelligent control LED light source which combine the control circuit and RGB chip together, integrated in a package of 5050 components. Adopts the parallel single wire control signal,owns the independent programmable address.WS2822S has the same outlook with 5050 RGB LED,each LED is one pixel.WS2822S LED has the power supply voltage stabilizing circuit,time base circuit,signal decoder block,data buffer,built-in address storage circuit EEPROM.Each pixel owns independent address,any pixel's failure won't affect any other pixel's display effect.

WS2822S's data protocol can compatible and expand the DMX512(1990) protocol signal.Data transmission speed can be 250Kbps~750Kbps.WS2822S has the independent write code signal line,the address can be written in series at one time.



### Mechanical Dimensions (unit:mm)

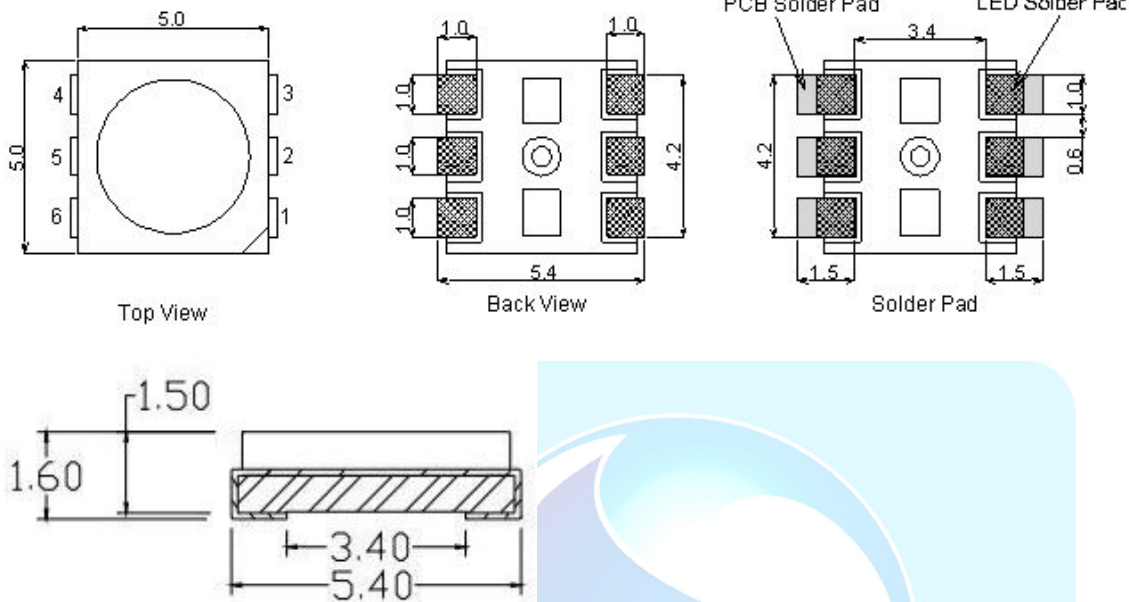

### PIN configuration

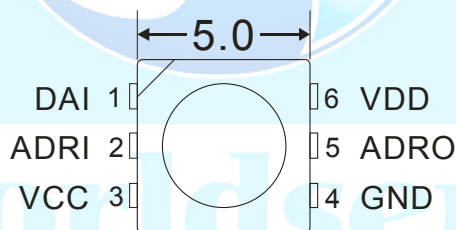

### PIN function

NO.	Symbol	PIN Name	Function Description
1	DAI	Data Input	Gray control data signal input port
2	ADRI	Address Input	Cascade address inputs port
3	VCC	IC Power Supply	Logic circuit power supply port
4	GND	Ground Port	Connect with Ground port
5	ADRO	Address Output	Cascade address output port
6	VDD	LED Power Supply	LED power supply port



### Maximum rating (Without special notes,TA=25°C,GND=0V)

Parameter	Symbol	Ratings	Unit
LED Power supply voltage	VDD	-0.5~+5.5	V
Logic Power supply voltage	VCC	-0.5~+5.5	V
Logic input voltage	Vi	-0.5~Vcc+0.5	V
Power consumption	PD	<250	mW
Working temperature	Topt	-25~+85	°C
Storage temperature	Tstg	-55~+150	°C
ESD	V <sub>ESQ</sub>	>2K	V

### Electrical Characteristics (T<sub>A</sub>=-20~70°C, GND=0V, V<sub>SS</sub>=0V,unless otherwise specified)

Parameter	Symbol	Testing conditions	Min.	Typical	Max.	Unit
LED Power supply voltage	VDD		3.6		5.5	
Logic Power supply voltage	VCC		4.5		5.5	V
Static current	I <sub>CC</sub>	VCC=5V	2.5	3	3.5	mA
DAI port flipped voltage	V <sub>IH</sub>	VCC=5V	3			V
	V <sub>IL</sub>				1.7	
Input current	I <sub>I</sub>	ADRI/ADRO=VCC/GND		±1		uA



### Gray control Data Communication Protocol :

(250K,frequency raising will leads time being changed)

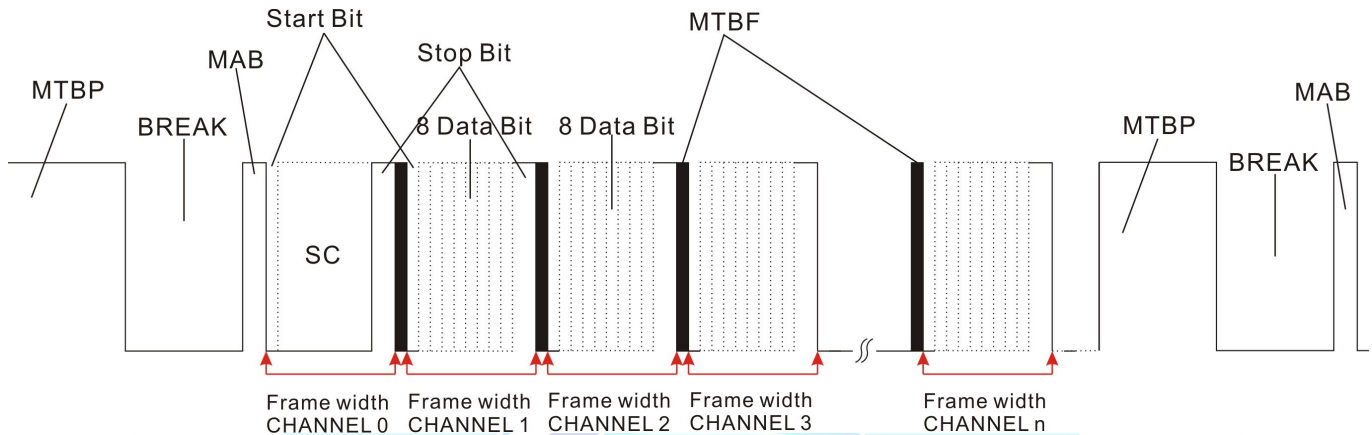

description	Min	Typ	Max	unit
MTBP	88	NS	1000000	us
BREAK	88	88	1000000	us
MAB	4	8	12	us
Frame width		44		us
Start Bit/Data Bit		4		us
Stop Bit		8		us
MTBF	0	NS	1000000	us

Note:NS means Not specified and designer definable

One entire data package consists of several data frames, each frame of data including 1 low start bit, 8 data bits, 2 stop bit high level. Control data is 8 bits, the level combinations from 00000000 to 11111111, total of 256 state (corresponding decimal number 0 ~ 255), control the brightness of light, can produce 256 brightness levels, 00000000 (0) corresponding to light the darkest, 11111111 (255) corresponding to the brightest lights. Packet first frames, lamps and lanterns corresponding to the first channel, second frames corresponding to the second channel lamp, and so on, 512nd frames corresponding to the 512nd channel lamp, lamp channel address can be set on the lamp.

One entire data package consists of one MTBP bit,one Break bit,one MAB bit,one SC(start code,means



start code frame) and some data frame, MFBB bit means time interval between frames to be a high level range is 0~1 seconds.

MTBP(Mark Time Between Packets) stands for after sending one entire data package, it will be the "vacant" bit for next data package's start, high voltage is effective. Break is interrupt, corresponding to a packet program reset stage after one package is over, width is no less than two frames (22bit) time.

After program reset, it will have a high level pulse MAB(Mark After Break) which have function of interval, separating function, once the pulse arrival, it means effective control data frame begin.

Each data frame consists of 11 data bits, the first bit (the start bit) is a low level, the middle 8 bits are with information data, high level is 1 code, low level code is 0 code, 10th and 11th bit data is the end bit with a high level.

Start code frame is the same with data frame later arrival, is composed of 11 bits, in addition to the two high level at the end position, the other 9 bits are all low level, usually known as the zeroth frame or zeroth channel (CHANNEL0), can be understood as an absence channel. Each data frame includes a 1 bit low level start bit, 8 data bits and 2 bits high level stop bit. Information data of 8 bits is low first, its level combinations from 00000000 to 11111111, totally have 256 states (corresponding to decimal number 0 ~ 255), during control the light brightness, it can produce 256 brightness levels, 00000000 (0) corresponding to light darkest, 11111111 (255) corresponding to the light brightest. In each data package, first frames corresponding to the first channel's lamp, second frames corresponding to the second channel's lamp, and so on, 3072nd frames corresponding to the 3072nd channel's lamp, the lamp channel's address can be set on the lamp, fixture channel address can be arranged in the lamp. This protocol is extended on the basis of the DMX512 protocol, the data rate range is 200KHZ to 750KHZ, the data frame contained in each package can be 3072 frames.



## Write address code data format

Use a similar gray control data protocol, frequency is 250kHz. Channel data package maximum has 3072 frames, when sending data usually high bit comes first. Each time you can send a data package for one time. Data package must be high level before and after sending the data package, before sending the data ,must have a above 5ms low level. Specific rules are listed in the following table:

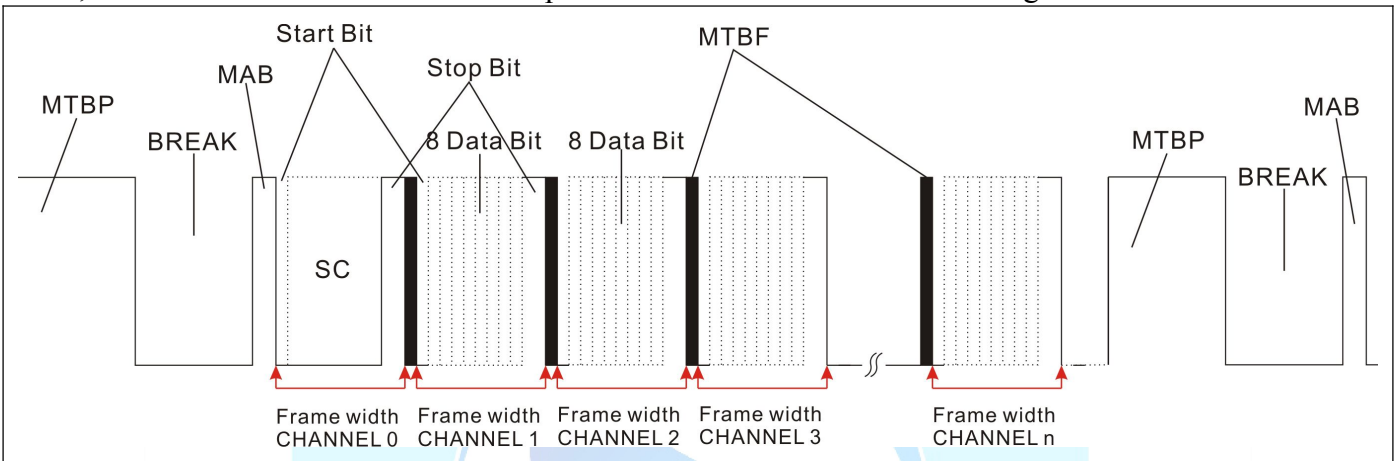

description	Min	Typ	Max	unit
MTBP	88	NS	NS	us
BREAK	5000	NS	1000000	us
MAB	8	12	88	us
Frame width		44		us
Start Bit/Data Bit		4		us
Stop Bit		8		us
MTBF	0	NS	1000000	us

Note: NS means Not specified and designer definable

Channel NO.		Frame width channel0	Frame width channel(1+m)	Frame width channel(2+m)	Frame width channel(3+m)
To set up the address values	Channel value				
0~255	Channel value	00h	00h~FFh	F0h	D2h
256~512			00h~FFh	E1h	
513~768			00h~FFh	D2h	
769~1024			00h~FFh	C3h	
1025~1280			00h~FFh	B4h	
1281~1536			00h~FFh	A5h	
>1536			00h~FFh	96h	

Note:m is a multiple of 3



Following graph is a waveform of addressing first pixel to be 4, 5, 6 and the second pixels to be 7, 8, 9 :

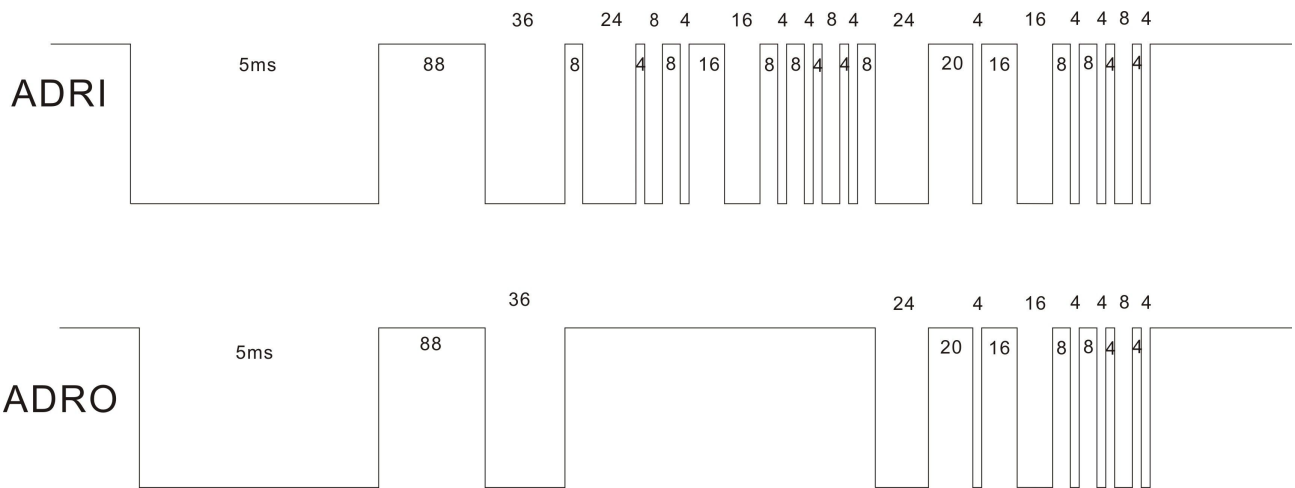

### Schematic diagram of Many pixel in parallel control:

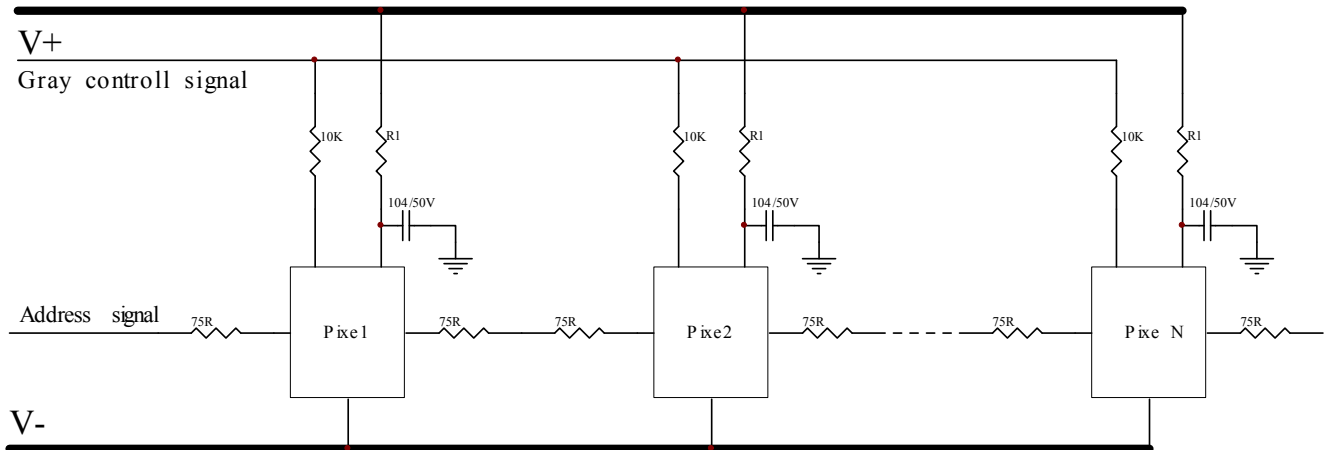

### Typical application:

