

## RS232 Router

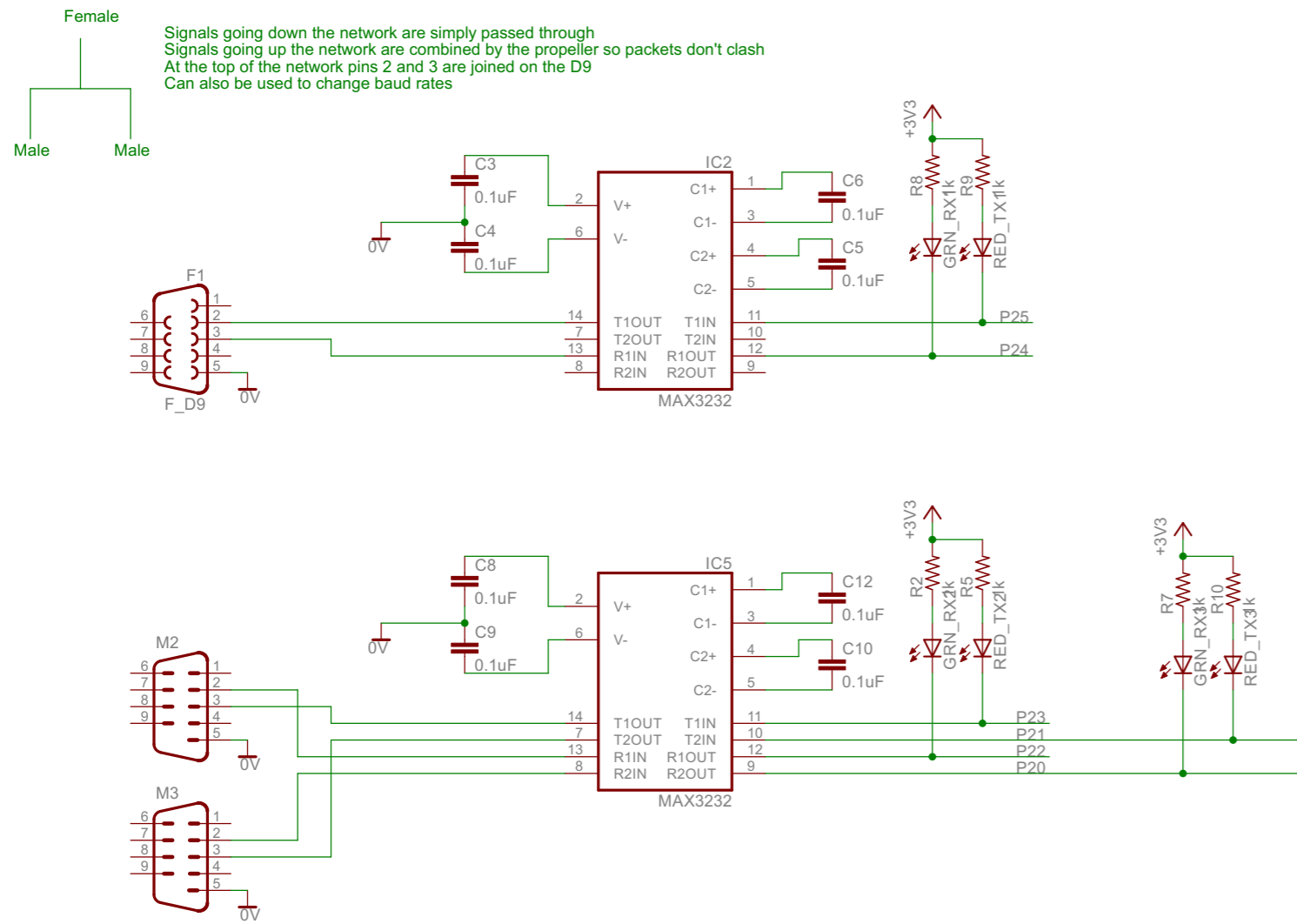

## Spare Pins

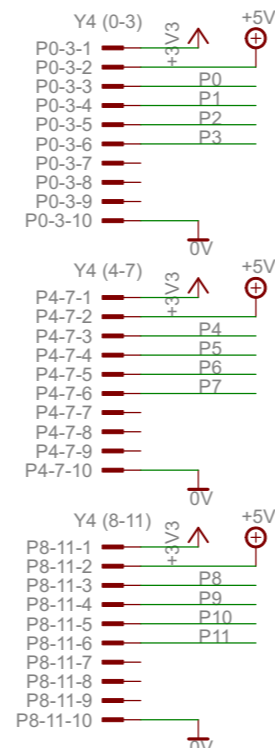

## SD Card

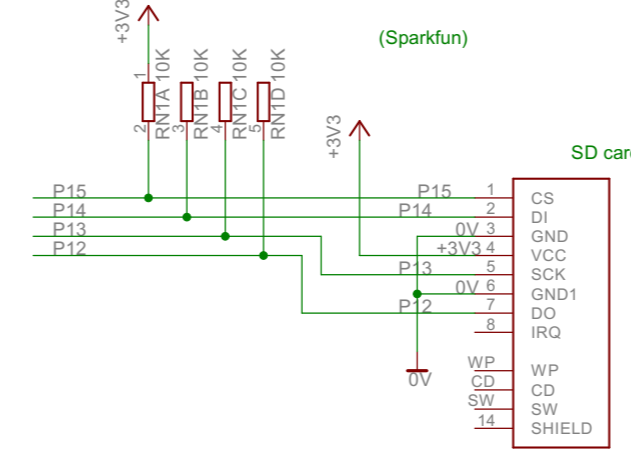

## Keyboard

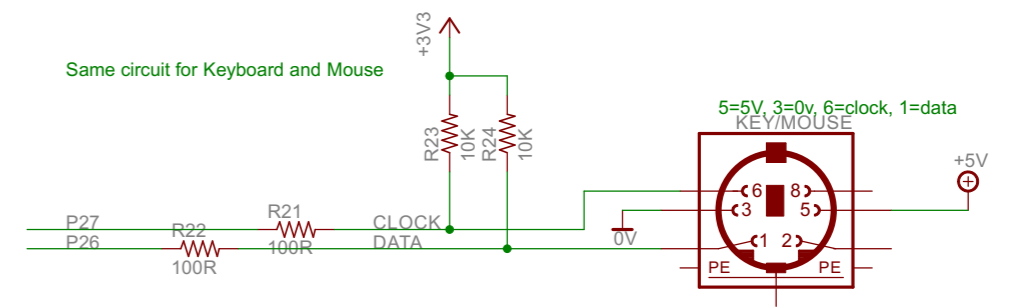

## TV

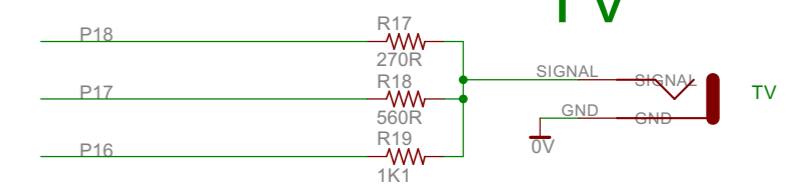

## Regulator

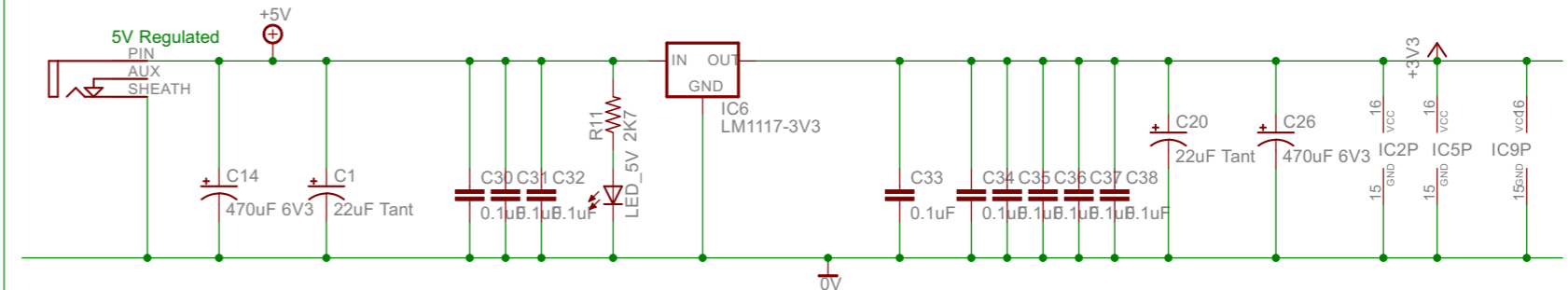

## Propeller

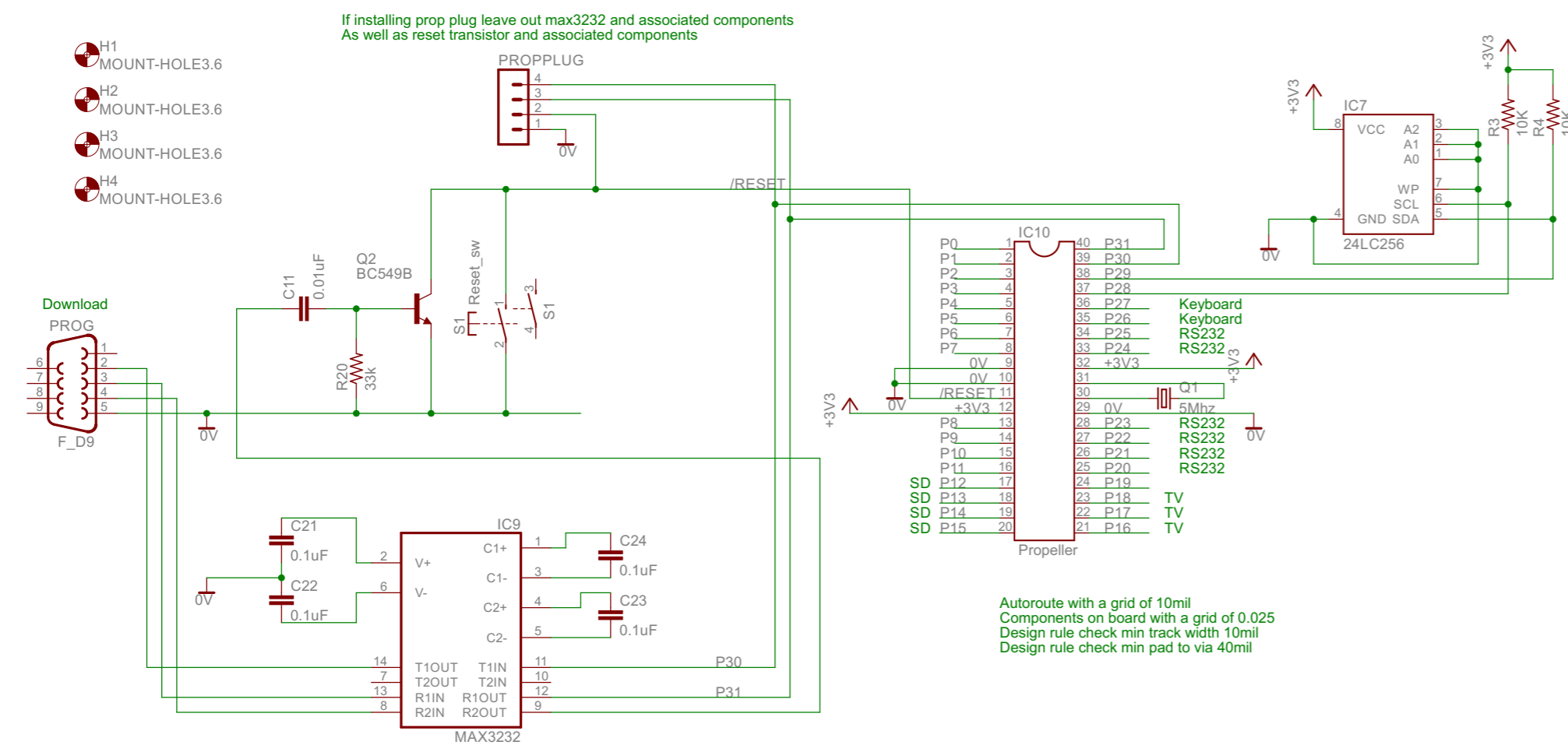

## Real World I/O (Arduino Layout)

