

---

**Dot Matrix LED Display  
Information Board  
User's Guide**

---

## Table of contents

---

<b>Chapter1. Brief Introduction .....</b>	<b>1</b>
1-1. Overview .....	1
1-2. Gallery .....	2
<b>Chapter2. Hardware Description .....</b>	<b>7</b>
2-1.Schematic .....	7
2-2. Main Features.....	8
<b>Chapter3. Application Notes .....</b>	<b>9</b>
3-1.Pin definitions .....	9
3-2. Timing Diagrams.....	10
3-3. Notes:.....	10
<b>Chapter4. Contact Us.....</b>	<b>12</b>

# Dot Matrix LED Display Information Board

---

## NOTES:

**Product Version** : **Ver 1.0**

**Document Version** : **Ver 1.0**

---

## **Chapter1. Brief Introduction**

---

### **1-1. Overview**

Dot Matrix LED Display Information Board is an economical solution for advertising or information application with various changing effects. It is suitable for applications in shops, restaurants, exhibition saloons, airports and railway stations etc. Dot matrix bicolor LED display information board features high resolution and gentle color and offers 4 different selections.

## Brief Introduction

---

### 1-2. Gallery

You may refer to the following table for details about Dot Matrix LED Display Information Board:

Product Number	Style	Diameter of each LED(mm)	Size	Color supported	Photo
DE-DP029	6416 bicolor	5	4.8inch*19.1inch	Red and green	Figure 1 (1) Not illuminated Figure 1 (2) Yellow snow
DE-DP030	6432 bicolor	5	9.6inch*19.1inch	Red and green	Figure 2 (1) Not illuminated Figure 2 (2) Yellow snow
DE-DP031	6416 unicolor	5	4.8inch*19.1inch	Red	Figure 3 (1) Not illuminated Figure 3 (2) Red koala
DE-DP032	6432 unicolor	5	9.6inch*19.1inch	Red	Figure 4 (1) Not illuminated Figure 4 (2) Red snow
DE-DP033	6432 bicolor	3	5inch*10inch	Red and green	Figure 5 (1) Not illuminated Figure 5 (2) Yellow koala

Figure 1 (1)

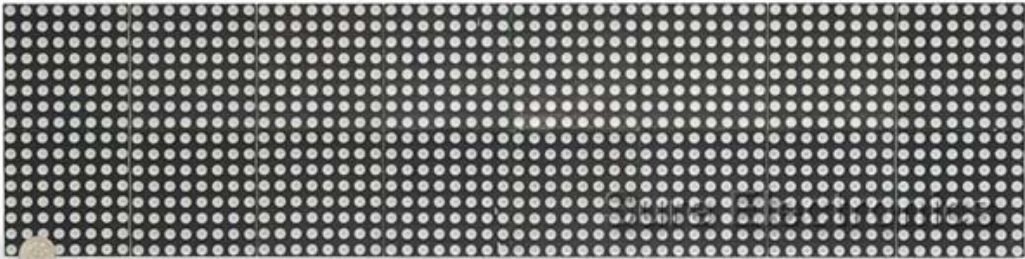

Figure 1 (2)



Figure 2 (1)

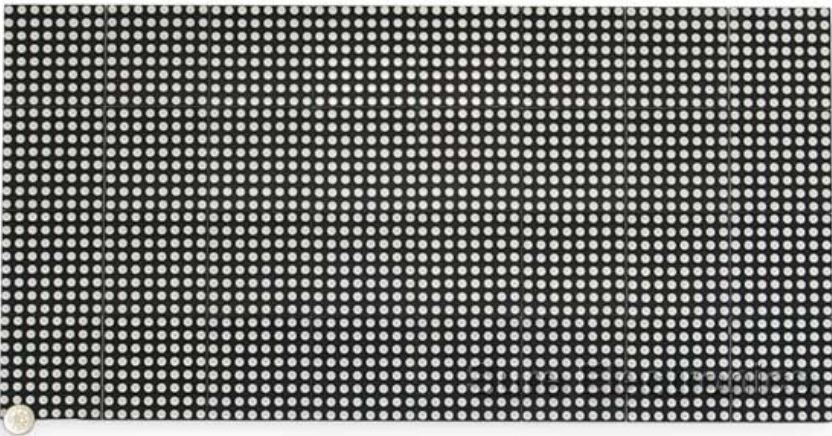

Figure 2 (2)

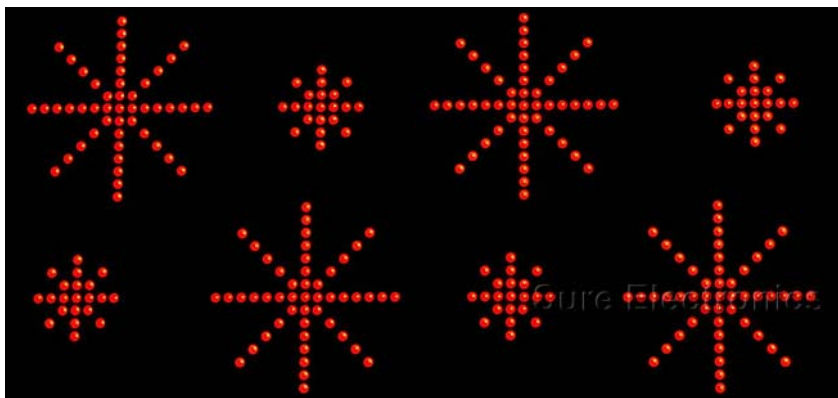

Figure 3 (1)

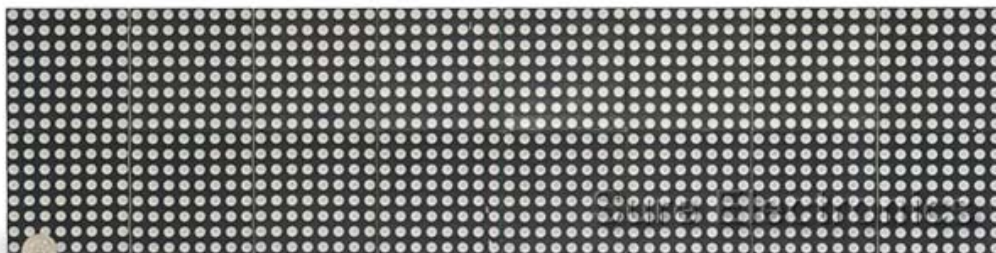

Figure 3 (2)



Figure 4 (1)

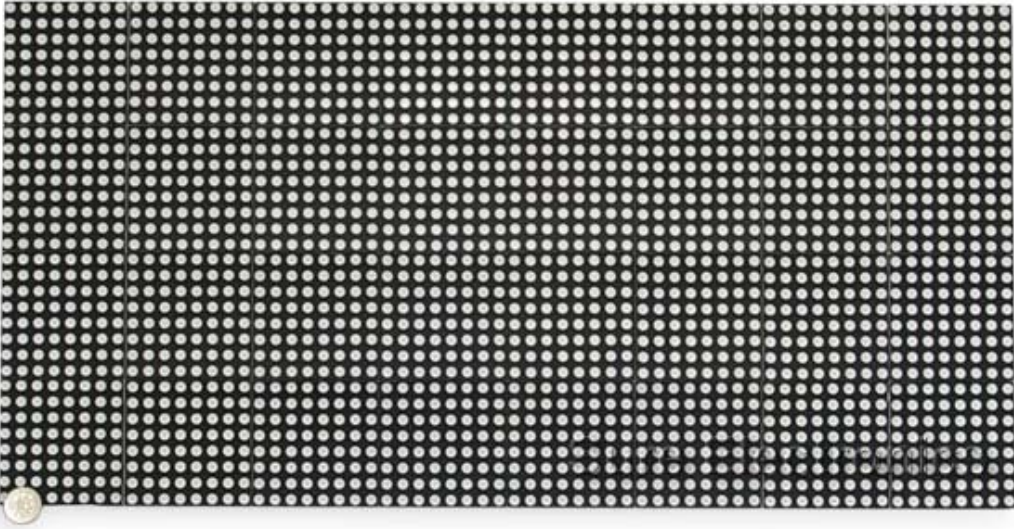

Figure 4 (2)

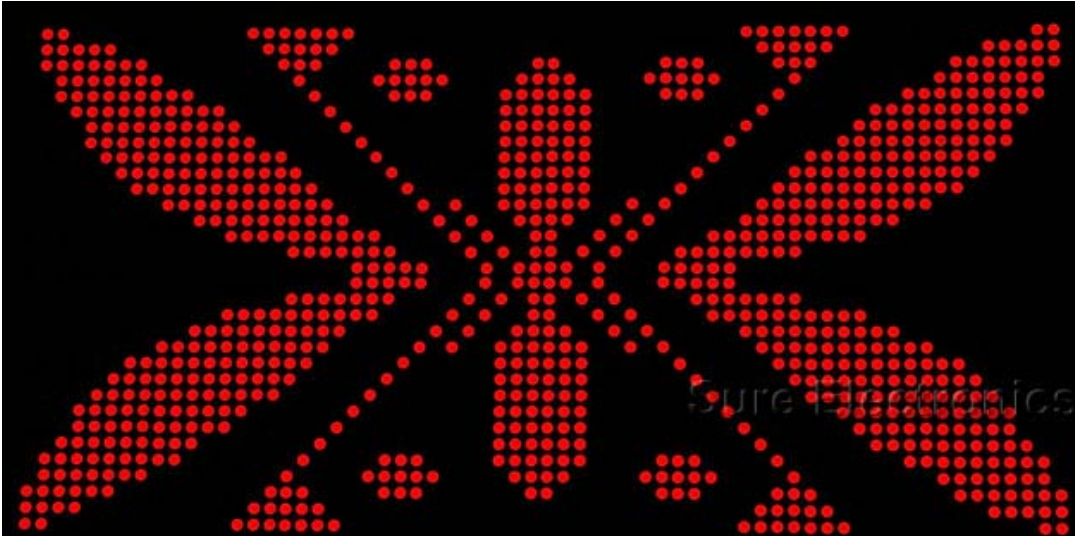



Figure 5 (1)

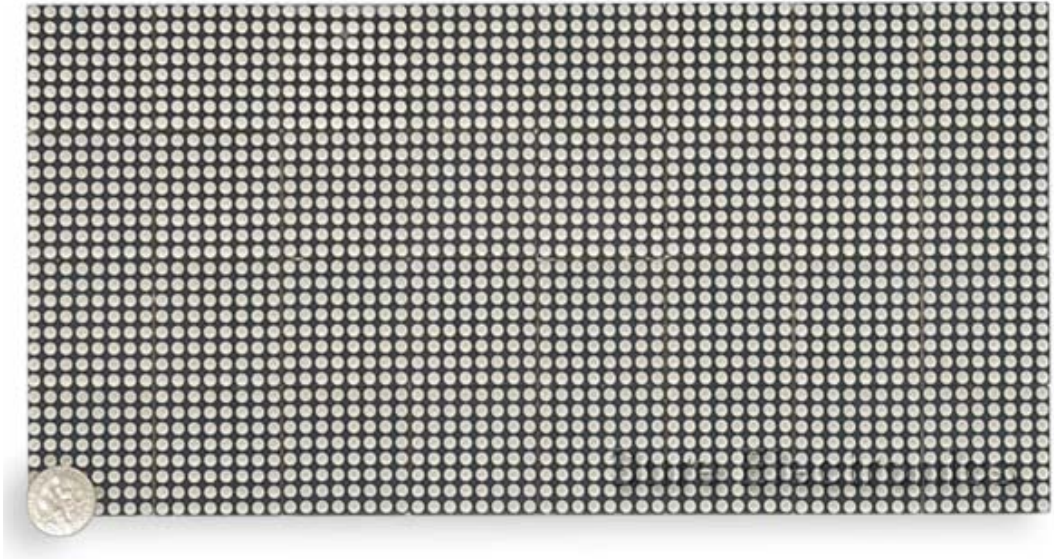
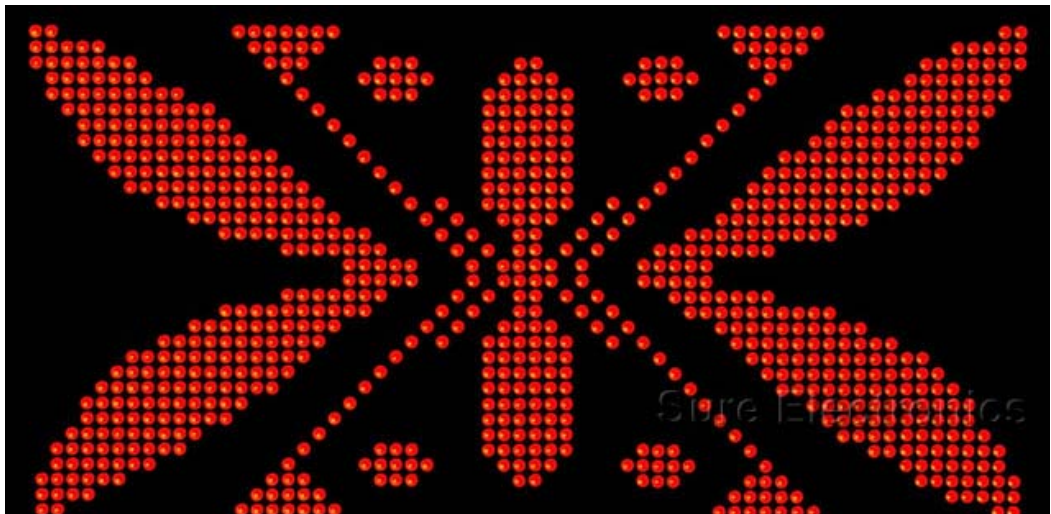

Figure 5 (2)



Note: when the LEDs are illuminated in both red and green, they display yellow effect

## Chapter2. Hardware Description

### 2-1.Schematic

The product family of dot matrix LED display information board shares the same features. The schematic below shows what a typical 6432 bicolor LED would be. Chip 74HC138 serves as a line selector which controls MOSFET in providing positive polar for LED while chip 74HC595 is a shift register for providing negative polar for each LED. In addition, a simple method to distinguish the LED board of its type is to check the amount of 74HC595 chip at the rear of each 8\*8 dot matrix, one suggests unicolor LED display and two suggests bicolor LED display.

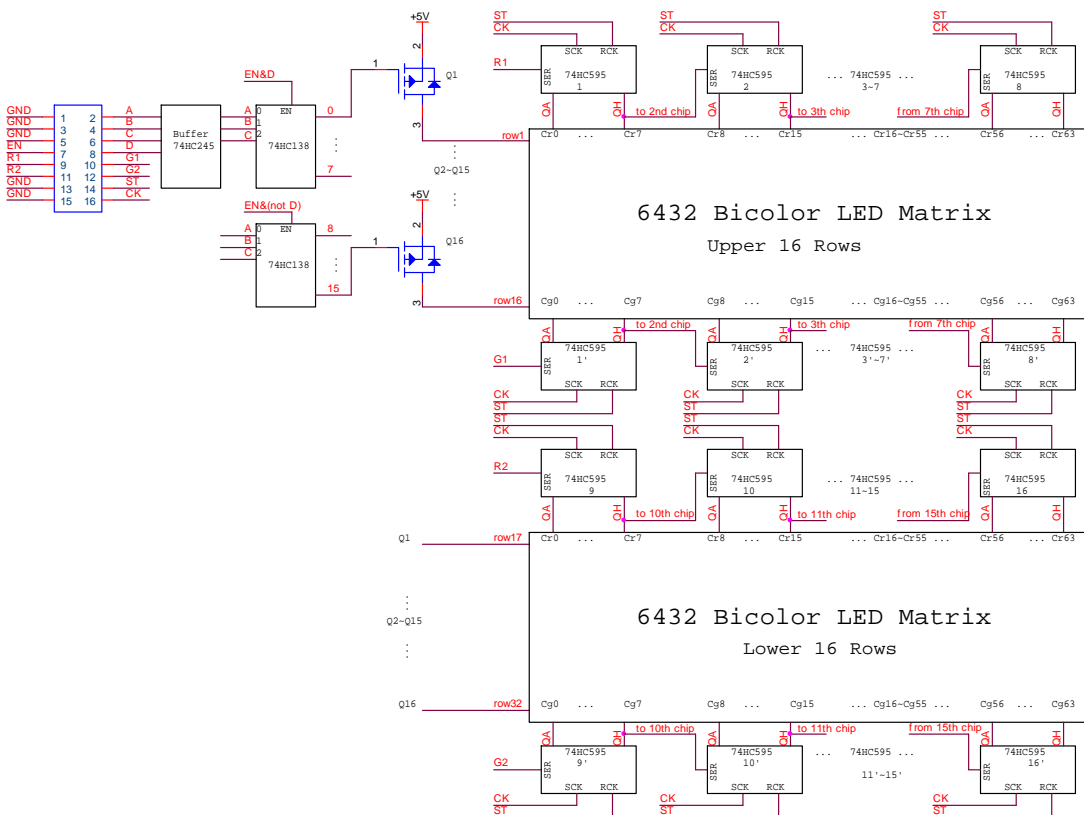

## Hardware Description

---

### 2-2. Main Features

- Programmable.
- Power supply voltage: 5V.
- when human eyes feel the displaying is stable and the brightness is appropriate, the maximum current of 6432(unicolor , 5inch\*10inch) is 1.49A (both halves are illuminated in red) and EN high level is holding for 150us, the frequency is 1.757khz. when characters can be displayed well, the current is approx 0.63A (25% of the red LEDs are illuminated). Users may refer to this specification for current of other types of dot matrix LED display.
- 6432/6416 dot matrix on each board.
- Gentle, comfortable and optional color: Green or Red.
- Each board contains 32 or 16 pieces of 0808 LED dot matrix modules.
- Serial MCU interface----R1/R2/G1/G2, CK,ST
- More boards can be connected in series for extended applications

## Chapter3. Application Notes

### 3-1.Pin definitions

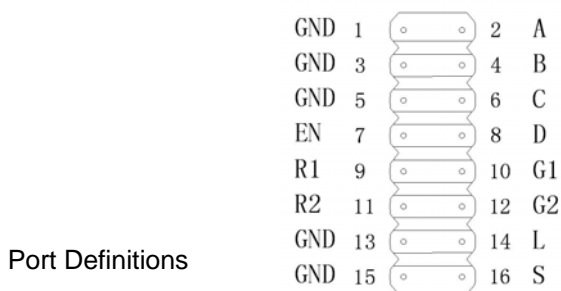

Port Number	Port	Function Description
1 ,3 ,5 ,13 ,15	GND	Ground Reference
7	EN	Enable 74HC138 encoder to set one of 16 rows.
9	R1	Data input for 74HC595 shift registers (active low). Data of 16 rows on upper side of 6432 dot matrix information board are provided by 8 pieces of 74HC595 shift register. LED emitting color is red.
11	R2	Provide data input for 16 rows on underside of 6432 dot matrix board. LED emitting color is red (active low).This pin is useless in 6416 board application.
2 ,4 ,6 ,8	A, B, C, D	These signals are transferred through buffers to strengthen themselves, and then sent to two pieces of 74HC138 encoder to enable one of 16 rows of 6432 dot matrix information board.
10 ,12	G1, G2	Their definitions are the same as those of R1 and R2. Except that their corresponding LED emitting color is green. They provide data to rows of 6432 dot matrix board via other 16 pieces of 74HC595 shift registers.
16	S	Clock input for 74HC595 shift register.
14	L	Contents of 74HC595 Shift Register transferred to output latches.

- Note: 1. Data for this board from 74HC595 shift registers is active low.  
 2. If you want to illuminate a LED, give 0, otherwise give 1.

## Application Notes

---

3. The first port sits across from port A. This may help users locate each port.
4. The LED of matrix board (Dia: 3mm) is effective when EN=0 while it's 1 for 5mm LED matrix board

### 3-2. Timing Diagrams

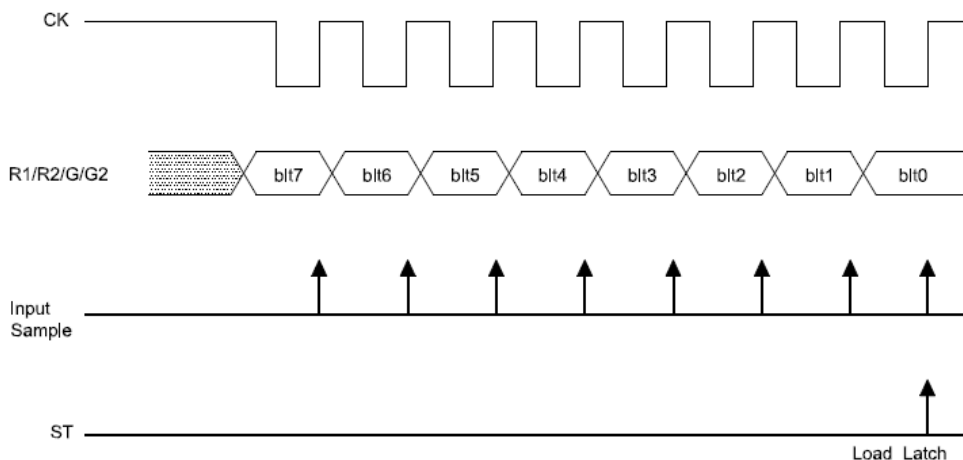

Figure 3

The board displaying frequency is 70 frame/s and screen refreshing should be completed in every frame.

The scanning time of one row should be no less than 0.78125ms.

The latch port will carry out a low level to high level conversion (0 to1) to output data for display after sending the 64 bits data.

### 3-3. Notes:

1. Secure the power supply and GND connection of the LED display with the DEMO board. Otherwise, the LED display cannot be illuminated.
2. Secure the connection of IDC with both double-row socket on board and interface at the rear of LED display. Firstly, the IDC shall be connected with the interface at the rear of LED display marked with "in", if you cannot find any interface marked with "in", you shall use the

one that sits closest to chip 74HC245. Pin 1 shall correspond to port 1 of the interface.

3 .Please be careful with the pins at the rear of LED display, they may pierce you finger.

4. The brightness that some of the LEDs of 6432/6416 dot-matrix display (10 pcs for 6432 and 5 pcs for 6416) give off are comparatively weak after illumination, which is normal.

---

## Chapter4. Contact Us

---

**Sure Electronics Co., Ltd.**

5F, Zone A,

Qinhuai Technology Innovation Center

105-2 DaMing Rd (Zip Code : 210022)

Nanjing

PRC

Tel: +86-25-66606340 (English Service) GMT1am-10am

Fax: +86-25-66606346

Website: [www.sure-electronics.net](http://www.sure-electronics.net)

[www.sureelectronics.net](http://www.sureelectronics.net)

[www.sure-electronics.com](http://www.sure-electronics.com)